

ENMET

680 Fairfield Court
Ann Arbor, MI 48108
734.761.1270 Fax 734.761.3220
www.enmet.com

ENMET
Creative Gas Detection Solutions



GSM-60 Operation Manual

Table of Contents

1.0 INTRODUCTION	3
1.1 Unpack.....	3
1.2 Check Order.....	3
1.3 Serial Numbers.....	3
2.0 INSTRUMENT FEATURES	4
2.1 Exterior Features.....	4
2.2 Display Panel Features.....	4
2.3 Circuit Board Features.....	6
3.0 INSTALLATION	7
3.1 Mounting of Instrument.....	7
3.2 Power Supply.....	8
3.3 Inputs / Outputs.....	8
3.3.1 <i>Sensor/Transmitter Connection</i>	9
3.3.2 <i>Relay Contacts</i>	9
3.3.3 <i>Optional 4-20mA Outputs</i>	10
3.4 Installation Verification.....	10
4.0 OPERATION	11
4.1 Normal Operation Condition.....	11
4.2 Alarm Set Points.....	11
4.3 Alarm Latching or Differential Settings.....	12
4.4 Audio Defeat.....	12
4.5 Display.....	12
4.6 Operational Menu.....	13
4.7 Fault Indications.....	14
4.7.1 <i>Low Flow Indication</i>	14
4.7.2 <i>Other Fault Indications</i>	14
4.8 Hydrocarbon Sensor Response.....	14
5.0 MAINTENANCE	15
5.1 Cleaning Instructions.....	15
5.2 Maintenance Menu.....	15
5.2.1 <i>Accessing Maintenance Menu</i>	15
5.2.2 <i>Maintenance Menu Flow Chart</i>	16
5.3 Calibration for CO, O ₂ , HC and CO ₂ (Gas Channels).....	17
5.3.1A <i>Low Cal/Zero Cal Adjust</i>	18
5.3.1B <i>High Cal/Span Gas Adjust</i>	19
5.3.2 <i>Set 4 –20mA Transmitter Scale</i>	19
5.3.3 <i>Set Alarm Points</i>	20
5.3.4 <i>Set Alarm Delay</i>	22
5.3.5 <i>Relay Configuration</i>	23
5.3.6 <i>Failsafe Configuration</i>	24
5.3.7 <i>Set Output Span Range</i>	24
5.3.8 <i>Set New Password</i>	25
5.3.9 <i>Exit Maintenance Menu</i>	25
5.4 Sensor Replacement.....	26
5.4.1 <i>Gas/Oxygen Sensor</i>	26
5.4.2 <i>Calibration/Sensor Replacement</i>	26
5.4.3A <i>Low Cal/Zero Cal Adjust</i>	28
5.4.3B <i>High Cal/Span Gas Adjust</i>	29
5.5 Flow Control Orifice.....	29
6.0 TECHNICAL DATA AND SPECIFICATIONS	29
7.0 REPLACEMENT PART NUMBERS	30
7.1 ENMET part numbers for sensors and replacement parts:.....	30
7.2 ENMET part numbers for Calibration equipment:.....	30
APPENDIX A: CO CHARACTERISTICS	31
APPENDIX B: GAS IONIZATION POTENTIALS	32

List of Figures

Figure 1: External Features of the GSM-60	5
Figure 2: GSM-60 Interior Features	6
Figure 3: GSM-60 Mounting Dimensions	7
Figure 2A: Relay, Input and Output Terminals.....	8
Figure 4: GSM-60 Operational Display	11
Figure 5: GSM-60 Operation Menu Flow Chart	13
Figure 6: GSM-60 Maintenance Menu Flow Chart.	16
Figure 7: GSM-60 Calibration Connections	18
Figure 9: Location of Gas Sensor and PiD(HC) Manifolds	26
Figure 7: GSM-60 Calibration Connections	28
Figure 10: Carbon Monoxide Concentration.....	31

List of Tables

Table 1 : Relay Failsafe Settings.....	10
Table 2: Sensor Output	10
Table 3: Typical Factory Alarm Set Points	11
Table 4: Factory Set Gas alarms Delay	22

Reference Information:

NOTE: [important information about use of instrument]

CAUTION: [affects equipment – if not followed may cause damage to instrument, sensor etc....]

WARNING: [affects personnel safety – if not followed may cause bodily injury or death.]



Attention / Warning



Earth Ground

1.0 Introduction

The **GSM-60** is a sample draw monitoring instrument that measures and detects certain toxic hazards gases. The **GSM-60** was designed primarily for monitoring one area with a single sampling hose, either for an individual gas or multiple gases. The instrument has one sampling pump and one flow sensor. The instrument is available with up to 4 internal sensors. Available sensors include, but are not, limited to carbon monoxide (CO), carbon dioxide (CO₂), Hydrocarbons (HC) and variations in the oxygen (O₂) content. The sensors can be used alone or up to four sensors can be used together. Some applications require monitoring of more than one area. If two sampling hoses are connected to one **GSM-60** the flow sensor can only detect a total flow fault condition. For example, a pump failure or both sampling hoses being blocked. The system cannot detect a flow fault if only one of the two sampling hoses is blocked.

Flowmeters should be installed in both sampling lines to provide a visual indication of proper flow. In the instrument, a 24 VDC sampling pump pass air over each sensor and the resulting electrical outputs are used to evaluate the air for the target gases.

The **GSM-60** is a highly adaptable instrument. Some adaptations require an addendum be added to the manual to facilitate use of the instruments with these adaptations. If addendum is needed, see page(s) between sections replacement part numbers and warranty.

Some features of the instruments are as follows:

- continuous monitoring of the sample air
- continuous LCD display of gas and vapor concentrations
- menu driven operational and maintenance controls
- menu driven calibration procedure
- audio and visual alarms indicate unsafe conditions
- alarm relay contacts available on terminals
- a fault relay and visual fault alarm
- low air flow fault indication and display
- alarm acknowledgement capability including audio defeat
- mA outputs for each target gas

Hydrocarbons (HC) are limited to gases with an ionization potential of 10.6 eV or less. See Appendix B for a list of gases and IPs.

NOTE: *All specifications stated in this manual may change without notice.*

1.1 Unpack

Unpack the **GSM-60** and examine it for shipping damage. If such damage is observed, notify both ENMET customer service personnel and the commercial carrier involved immediately.

Regarding Damaged Shipments

NOTE: *It is your responsibility to follow these instructions. If they are not followed, the carrier will not honor any claims for damage.*

- This shipment was carefully inspected, verified and properly packaged at **ENMET** and delivered to the carrier in good condition.
- When it was picked up by the carrier at **ENMET**, it legally became your company's property.
- If your shipment arrives damaged:
 - Keep the items, packing material, and carton "As Is." Within 5 days of receipt, notify the carrier's local office and request immediate inspection of the carton and the contents.
 - After the inspection and after you have received written acknowledgment of the damage from the carrier, contact **ENMET** Customer Service for return authorization and further instructions. Please have your Purchase Order and Sales Order numbers available.
- **ENMET** either repairs or replaces damaged equipment and invoices the carrier to the extent of the liability coverage, usually \$100.00. Repair or replacement charges above that value are your company's responsibility.
- The shipping company may offer optional insurance coverage. **ENMET** only insures shipments with the shipping company when asked to do so in writing by our customer. If you need your shipments insured, please forward a written request to **ENMET** Customer Service.

Regarding Shortages

If there are any shortages or questions regarding this shipment, please notify **ENMET** Customer Service within 5 days of receipt at the following address:

ENMET
680 Fairfield Court
Ann Arbor, MI 48108
734-761-1270 Fax 734-761-3220
Toll Free: 800-521-2978

1.2 Check Order

Check, the contents of the shipment against the purchase order. Verify that the **GSM-60** is received as ordered. If there are accessories on the order, ascertain that they are present. Check the contents of calibration kits. Notify ENMET customer service personnel of any discrepancy immediately.

1.3 Serial Numbers

Each **GSM-60** is serialized. These numbers are on tags on the equipment and are on record in an ENMET database.

2.0 Instrument Features



2.1 Exterior Features

The exterior of the instrument is shown in **Figure 1**. The exterior features are as follows:

Feature	Description
Enclosure	An engineered thermoplastic box, approximately 10x8x6, with a clear hinged front cover.
Input Port	The entrance for the air sample and calibration gas. The quick release fitting mates with one on the calibration adapter.
Front Cover Latch	A quick-release latch that holds the clear front cover in place, and is capable of being padlocked if desired.
Audio Alarm	A loud horn activated by certain alarm conditions.
Mounting Flanges	Flanges with holes for mounting the enclosure to a vertical surface.
Output Port	The exit to exhaust the air sample and calibration gas. Luer fitting.

2.2 Display Panel Features

The display panel, shown in **Figure 1**, is viewed through the clear front cover of the enclosure, and is accessed by opening the cover. Features are as follows:

Feature	Description
Display	A 2 line, 16 character per line, LCD with backlight. The numerical values of gas concentrations, and other information are displayed.
Visual Alarms & Indicators	On either side of the display: A red alarm LED for each sensor installed in the instrument, Low level alarm. The top center of the panel: A red alarm LED for all sensors installed in the instrument, High level alarm. Near the center of the panel: A green power indicator LED A red fault alarm indicator LED
Pushbutton Switches	There are three of these, located near the center of the panel; they are yellow rectangular membrane switches. They are:
• OPTION Switch	The top left switch. 
• SELECT Switch	Directly to the right of the OPTION switch. 
• Audio Defeat / Alarm Acknowledge Switch	Directly below the OPTION switch. 

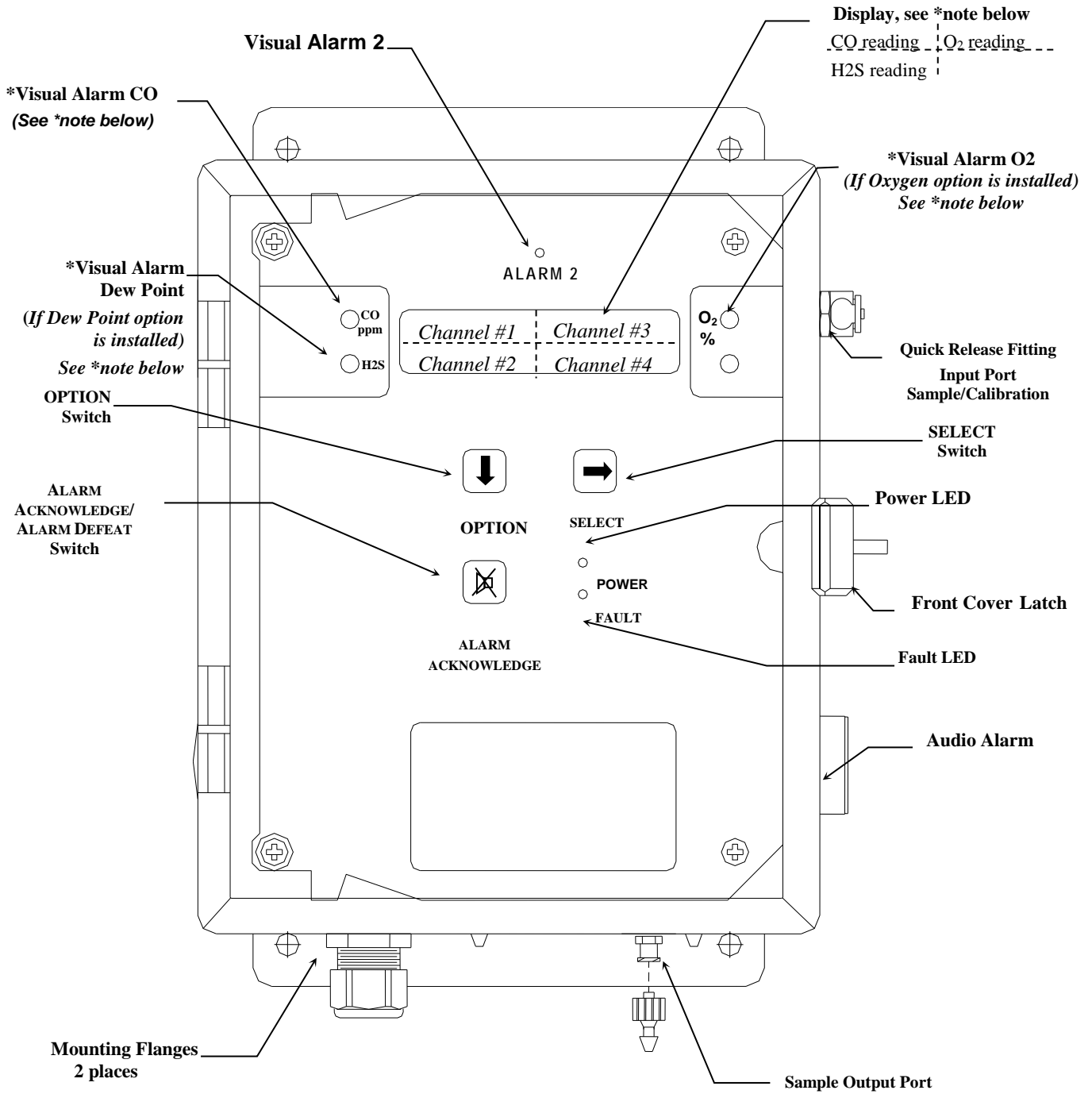

Figure 1: External Features of the GSM-60

* **NOTE:** Typical gas reading & alarm locations, depending on instrument configuration, alarms & readings may be in alternate locations

2.3 Circuit Board Features

The Display Panel is hinged on the left and is released by unscrewing the 2 screws located in the right corners. After releasing the panel, it is swung to the left, exposing the interior of the enclosure. The Circuit Board is mounted at the back surface of the enclosure interior. Features are shown in **Figure 2**.

Feature	Description
Relay Terminals	This group of terminals is located at the left side of the Circuit Board. For the contacts for each of four alarm relays, and for the contacts of a fault relay.
Output Terminals	One 4-20mA output per active channel. 2 channels/outputs per connector.
HC Manifold Sensor Manifold	The PiD sensor is installed into this housing. The sample manifold, the carbon monoxide, carbon dioxide and oxygen sensors are located under this housing.
Filter, Particulate	Removes contaminate from air sample line.
Sensor Terminals J16, J18, J19	Sensor/Transmitter connectors 24VDC 4-20mA Input

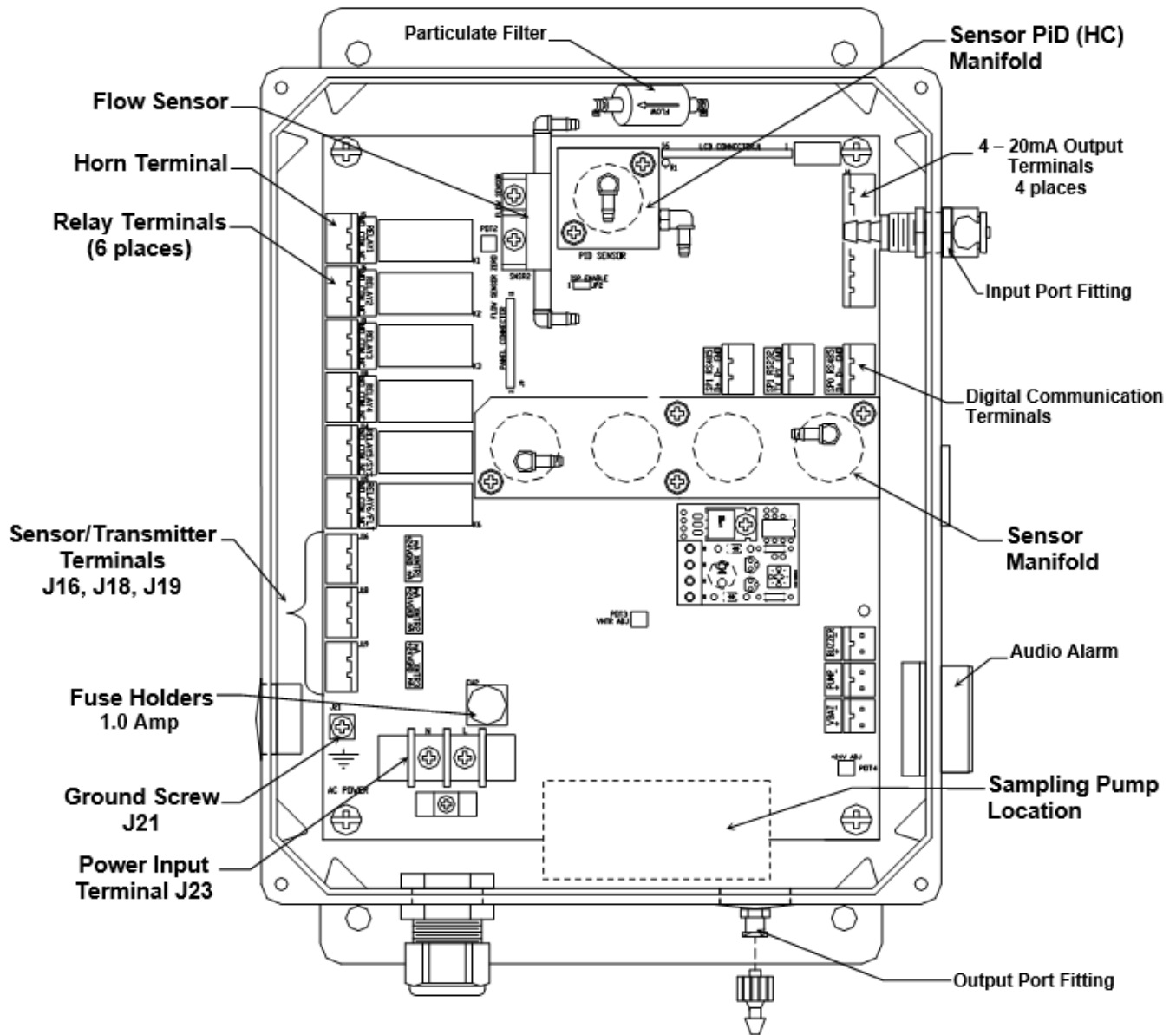

Figure 2: GSM-60 Interior Features

3.0 Installation

3.1 Mounting of Instrument

The **GSM-60** should be located near the air to be monitored. Sampling lines should be no more than 50 feet long. It is recommended that Teflon® (PTFE) lined tubing be used. Quick disconnect fittings are supplied for use with 1/8" ID tubing. Mount the instrument on an appropriate vertical surface using the mounting flanges provided. Avoid areas with excessive vibration or temperature extremes. The holes in the flanges are 0.31 inch in diameter and form a 6 x 10.75-inch rectangle. **See Figure 3.**

It is recommended to use #8 drywall anchors and screws for mounting the **GSM-60** to a drywall/sheetrock surface.

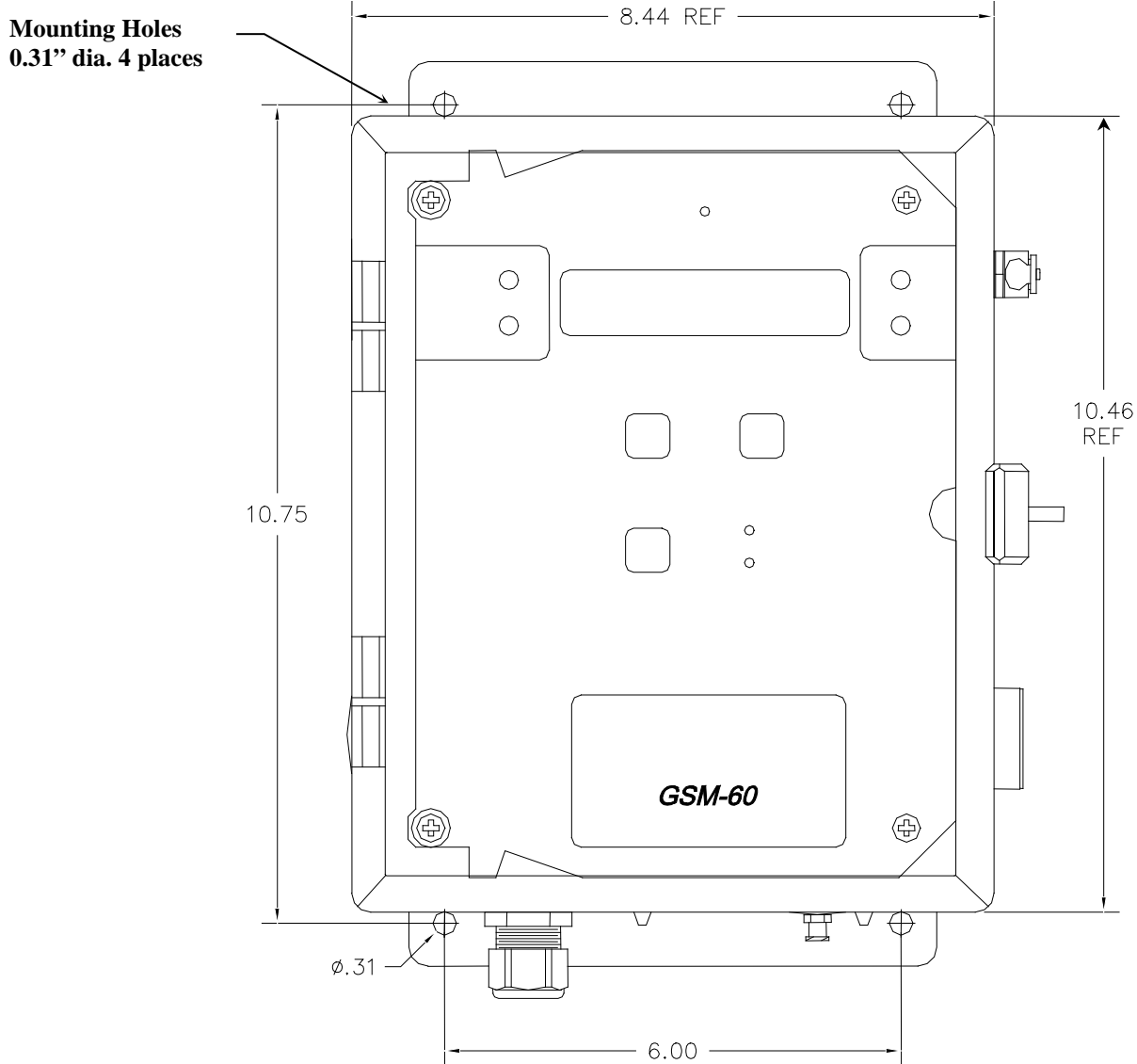

Dimensions are in inches.

Figure 3: GSM-60 Mounting Dimensions

3.2 Power Supply

The input power can vary from 100 to 240VAC, 50/60 Hz. Mains power should be connected to the Power Input Terminal **J23** and the ground screw **J21**. See **Figure 2** for location.

WARNING: Continuous gas detection and alarm systems (110VAC/220VAC / 24VDC/12VDC powered) become inoperative upon loss of primary power. Contact factory for specifications and pricing of backup battery systems.

Upon supplying air and power to the instrument:

- The green power on LED is lit.
- The display backlight is lit, and instrument will step through a start-up sequence: unit serial number, software revision and gases monitored may be shown on the display.

The instrument may go into alarm briefly, but the sensors stabilize quickly. If the instrument persists in alarm, acknowledge the alarm by pressing the **AUDIO DEFEAT / ALARM ACKNOWLEDGE** switch. If alarm persists longer than 30 minutes, call **ENMET** customer service personnel.

3.3 Inputs / Outputs

Two types of alarm outputs are available, relay contacts and 4-20mA outputs.

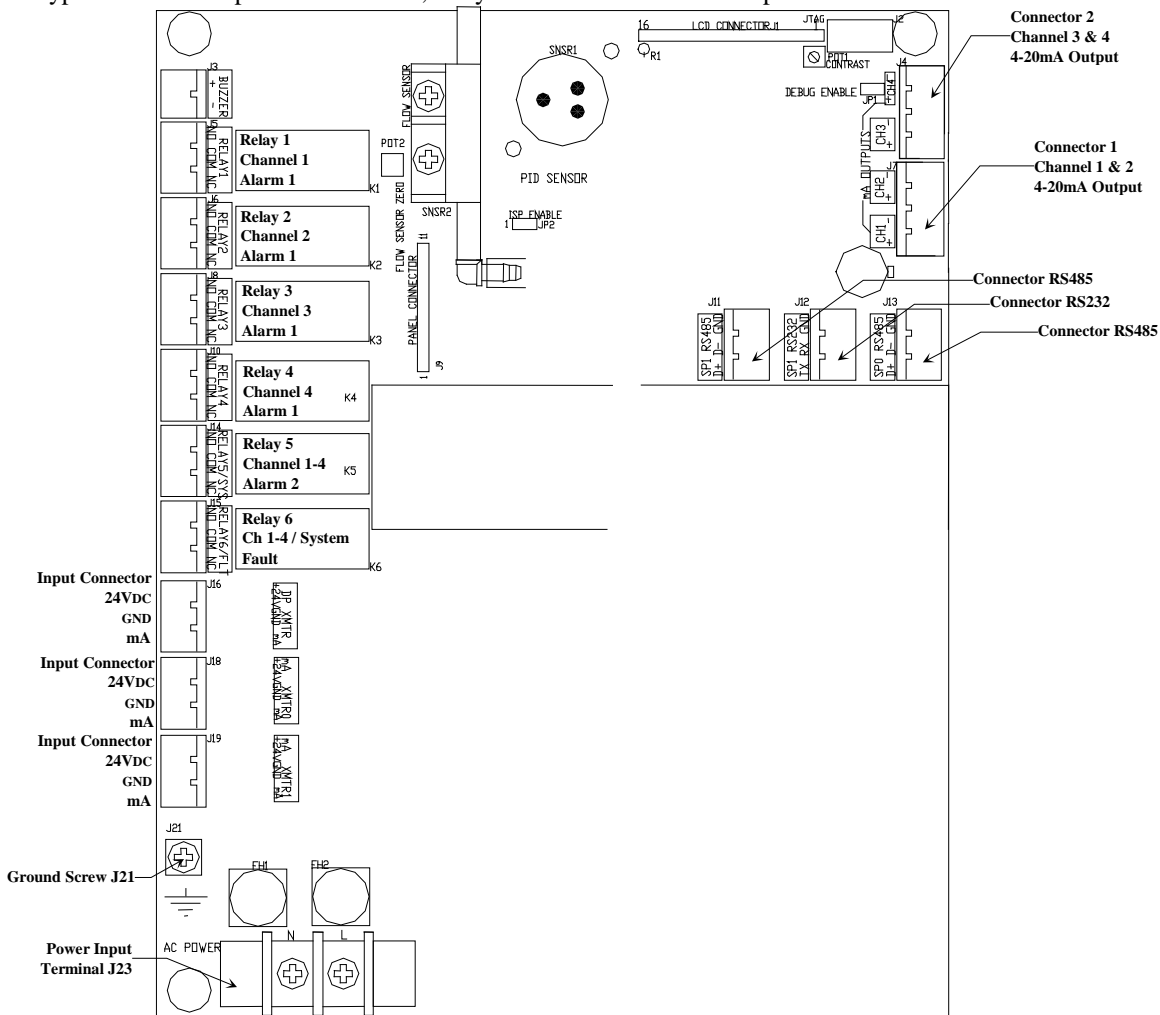

Figure 2A: Relay, Input and Output Terminals

3.3.1 Sensor/Transmitter Connection

Sensor/Transmitters are connected to the **GSM-60** control unit with two or three-conductor wiring, use the correct oil tight fitting. Size of wire depends on the distance between the sensor/transmitter and the control unit. See Recommended Wire Gauge Table below.

2 Wire for Sensors/Transmitter		3 Wire for Sensors/Transmitter	
Position	Function	Position	Function
1	Power +24 VDC	1	Power +24 VDC
2	Not Used	2	Power Ground
3	Signal/Return to Ground	3	Signal

Recommended Wire Gauge

Distance from Sensor to Control Unit	Recommended Wire Gauge
< 500 feet	16 AWG
501 – 800 feet	14 AWG
Longer Distances	Contact Factory

NOTE: Sensor Location

Gases have different densities. Some are heavier than air and concentrate at the bottom of a space. Some are lighter than air and gather at the top. Consider the density of the gas you want the sensor to detect when you install the sensor. Some examples are given below.

Heavier than Air Gas	Sensor Location
Bottled LP (liquefied petroleum)	<p style="text-align: center;">Interior wall; 18-24" from floor.</p> <ul style="list-style-type: none"> DO NOT locate directly above or beside gas appliances (ovens, heaters). Avoid locating anywhere near a vent or window or near an outside doorway.
Propane	
Butane	
Gasoline	
Trichloroethylene	
Vaporized hydrocarbons	
Hydrogen sulfide	
Lighter than Air Gas	Sensor Location
Natural gas (methane)	Near ceiling.
Ammonia	<ul style="list-style-type: none"> DO NOT locate directly above appliances where it is subject to direct exposure to heat or steam.
Hydrogen	
Same Density as Air Gas	Sensor Location
Carbon Monoxide	4-6 feet above the (generally uniform) floor. <ul style="list-style-type: none"> DO NOT locate in direct air currents of windows, doors, or vents.

If you have a question involving the location of a unit or sensor, please contact your distributor or **ENMET** personnel. A technician will analyze the question and recommend a location.

3.3.2 Relay Contacts

Relay contacts are available for each alarm; these are SPDT, rated at 10Amp at 110VAC, and may be latching or non-latching as required by the application.

They are accessed on the terminals next to each relay see **Figure 2 & 2A**. The contact positions are noted on the circuit board next to each terminal.

Relays may also be configured as failsafe or non-failsafe. The default alarm relay configuration is for latching mode, and failsafe. They may be reconfigured in the maintenance menu. **See section 5.3.5 & 5.3.6**

The PC Board is labeled for the relays in their un-energized state. If the relay is configured for failsafe, then this is also the alarm condition state. Non-failsafe configured relays in the alarm state, are the reverse of the PC board labeling. Note that the Fault (FLT) relay cannot be set to operate in a Non-Failsafe mode. Please see the **Table 1** on page 10:

Table 1 : Relay Failsafe Settings

Position	Failsafe-Alarm	Non-Failsafe-Alarm
J5 Relay 1 - NO	Normally Open	Normally Closed
J5 Relay 1 - COM	Common	Common
J5 Relay 1 - NC	Normally Closed	Normally Open
J6 Relay 2 - NO	Normally Open	Normally Closed
J6 Relay 2 - COM	Common	Common
J6 Relay 2 - NC	Normally Closed	Normally Open
J8 Relay 3 - NO	Normally Open	Normally Closed
J8 Relay 3 - COM	Common	Common
J8 Relay 3 - NC	Normally Closed	Normally Open
J10 Relay 4 - NO	Normally Open	Normally Closed
J10 Relay 4 - COM	Common	Common
J10 Relay 4 - NC	Normally Closed	Normally Open
J14 Relay 5 - NO	Normally Open	Normally Closed
J14 Relay 5 - COM	Common	Common
J14 Relay 5 - NC	Normally Closed	Normally Open
J15 Relay 6/FLT - NO	Normally Open	N/A
J15 Relay 6/FLT - COM	Common	N/A
J15 Relay 6/FLT - NC	Normally Closed	N/A

Relays can be linked to specific alarms. The table below shows the default relay links. They may be changed in the maintenance menu if required. See **Section 5.0**.

	Channel 1	Channel 2	Channel 3	Channel 4
Relay 1	Low Alarm			
Relay 2		Low Alarm		
Relay 3			Low Alarm	
Relay 4				Low Alarm
Relay 5	High Alarm	High Alarm	High Alarm	High Alarm

In addition, there is a fault relay, which changes state whenever the instrument is in a fault condition. The contact positions are noted on the circuit board next to each terminal. See **Figure 2A**. The coil of this relay is energized when the instrument is in the non-fault state; the contact conditions given on the circuit board next to the terminal, are for the non-energized state, which is identical to the fault state.

These relay contacts can be used to operate auxiliary alarms or other functions. It is recommended that power for auxiliary equipment be supplied from an independent power source, separate from the **GSM-60**. Place a hole in the enclosure for a wire exit, and use appropriate cable fittings. Be sure to note the location and depth of hardware inside the enclosure.

3.3.3 Optional 4-20mA Outputs

Isolated 4-20 mA outputs are available for data logging or other purposes. An output is supplied for each sensor supplied in an instrument, and can be added when a sensor is added in the field. These outputs are available on the Connector 1 for channels 1 & 2 and Connector 2 for channels 3 & 4.

4mA corresponds to a sensor reading at the bottom of the instrument range and 20mA corresponds to a full-scale reading. Standard ranges are shown in **Table 2**.

Table 2: Sensor Output

Sensor	4mA	20mA
CO	0	50
O2	0	30
CO2	0	5000
HC	0	100

Wiring requirements are the same as for the relays.

3.4 Installation Verification

All instruments are calibrated at the factory. You may, if a calibration kit is available, calibrate the all gas channels of the instrument 24 hours after installation to verify proper installation and instrument operation. See **Section 5.0**, Maintenance, for calibration instructions. Calibration is also recommended after the first month of operation. Subsequent calibrations should be performed every 3 months. The dew point sensor cannot be calibrated in the field.

4.0 Operation

4.1 Normal Operation Condition

With the **GSM-60** installed as described in **Section 3**, and in clean air, the POWER green LED is on, the display is lit and the information on the display is as shown in **Figure 4 Display**, for the sensor(s) installed in the **GSM-60**. The red alarm and fault LEDs are not lit.

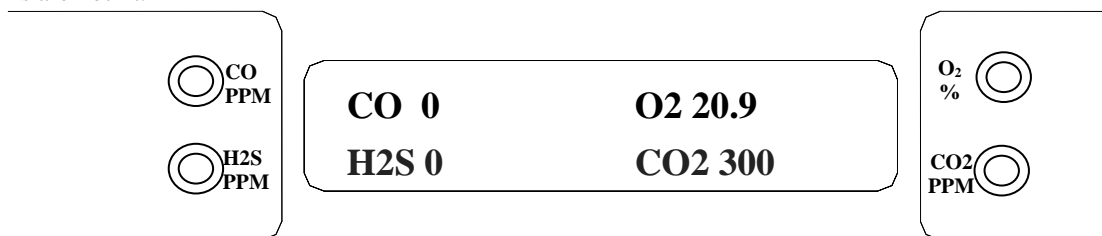

Example of display with CO (ch 1), H₂S (ch 2), Oxygen (ch 3) and CO₂ (ch 4) options installed

Figure 4: GSM-60 Operational Display

4.2 Alarm Set Points

There are two alarm set points for each installed channel of the **GSM-60**. The factory settings of these alarm set points are shown in **Table 3**.

Table 3: Typical Factory Alarm Set Points

Typical Channel #	Gas	Alarm 1, Flashing LED	Alarm 2, Steady LED
1	Carbon Monoxide	10 ppm	20 ppm
2	Hydrogen Sulfide	10 ppm	20 ppm
3	Oxygen Deficiency	19.5 % by volume	23.5 % by volume
4	Carbon Dioxide	500 ppm	1000 ppm
4	Hydrocarbon	5 ppm	10 ppm

The alarm set points can be changed within limits; see the maintenance section of this manual for the procedure.

- If the CO concentration increases above that of the alarm set point, the associated red LED is lit, the associated relay changes state, and the audio alarm is activated.
- If the dew point increases above that of the alarm set point, the associated red LED is lit, the associated relay changes state, and the audio alarm is activated.
- If the oxygen content of the sample air decreases below the deficiency alarm set point, the associated red LED is lit, the associated relay changes state, and the audio alarm is activated.
- If the oxygen content of the sample air exceeds that of the abundance alarm set point, the associated red LED is lit, the audio alarm is activated, and both the oxygen alarm relay and the oxygen high alarm relay change state.
- The HC sensor can only detect and alarm to hydrocarbons with an Ionization Potential of less than 10.6 eV. See **Appendix B**.
- The HC sensor is broad range in nature and is unable to differentiate between different hydrocarbons.
- The Alarm 1 differential value is the delay of the **GSM-60** staying in alarm condition until after the measured reading has returned past the alarm point by the differential value. *Example:* If the alarm set point is Δ 10 and the differential is 2, the **GSM-60** will go into alarm at 10 and stay in alarm until the reading has dropped below 8.

4.3 Alarm Latching or Differential Settings

An instrument is shipped with the alarms in the latching mode. The alarms may be independently configured in the non-latching mode or differential setting by use of the maintenance menu.

See Section 5.3.3, for setting alarm 1 and alarm 2.

Standard Setting

- IN THE LATCHING MODE: at the cessation of the condition which causes an alarm, the alarm indications do not cease, and the alarm relay contacts do not revert to the non-alarm state, until the **AUDIO DEFEAT / ALARM ACKNOWLEDGE** switch is pressed. An alarm can also be acknowledged by pressing the switch during the alarm condition; then at the cessation of the alarm condition, alarm indications cease and alarm relays revert to the non-alarm state. After an alarm is acknowledged, alarms in the latching configuration are re-armed to latch at the next alarm condition.
- IN THE NON-LATCHING MODE: at the cessation of the condition that causes an alarm, the alarm indications automatically cease, and the alarm relay contacts revert to the non-alarm state.

Differential Setting

- The Alarm 1 differential value is the delay of the **GSM-60** staying in alarm condition until after the measured reading has returned past the alarm point by the differential value. *Example:* If the alarm point is Δ 10 and the differential is 2, the **GSM-60** will go into alarm at 10 and stay in alarm until the reading has dropped below 8.

4.4 Audio Defeat

Pressing the **AUDIO DEFEAT / ALARM ACKNOWLEDGE** switch during an alarm temporarily silences the audio alarm. Relays and alarm LEDs continue to function, in the alarm state, during an alarm condition. If the alarm condition persists, the audio alarm will “chirp” every 20 seconds.

- If after 15 minutes the alarm condition continues the audio alarm will reactivate at full intensity.
- If any other alarm condition occurs while the audio alarm has been silenced it will force the audio alarm to reactivate immediately.

4.5 Display

In clean air a display is shown in **Figure 4**. This position of the display is termed the "**operational display**". As explained below, the display can be used to view other information by using the **OPTION** and **SELECT** switches.

Concentrations of CO and CO₂ are given in PPM (parts per million parts of air). Dew point is given in degrees Fahrenheit at 55 PSIG; *this can be changed to degrees Centigrade by pressing the SELECT switch*. Oxygen concentration is given in percent by volume.

When sample flow is reduced below a limit, the bottom line of the display flashes “Low Flow Alarm”.

4.6 Operational Menu

The operational menu allows the user to:

- View alarm set point concentration values
- View alarm ascending/descending trigger, latching and delay configurations
- Enter the maintenance menu with the proper Password.

The operational menu is accessed with the **OPTION** and **SELECT** switches. The operational menu flow chart is shown in **Figure 5**,

- Pressing the **OPTION** switch is indicated with a "O"
- Pressing the **SELECT** switch is indicated with a "S".

If the instrument is left at any location in the operational or maintenance menus, other than the operational display, with no action taken for a period of 45 seconds, it returns to the operational display.

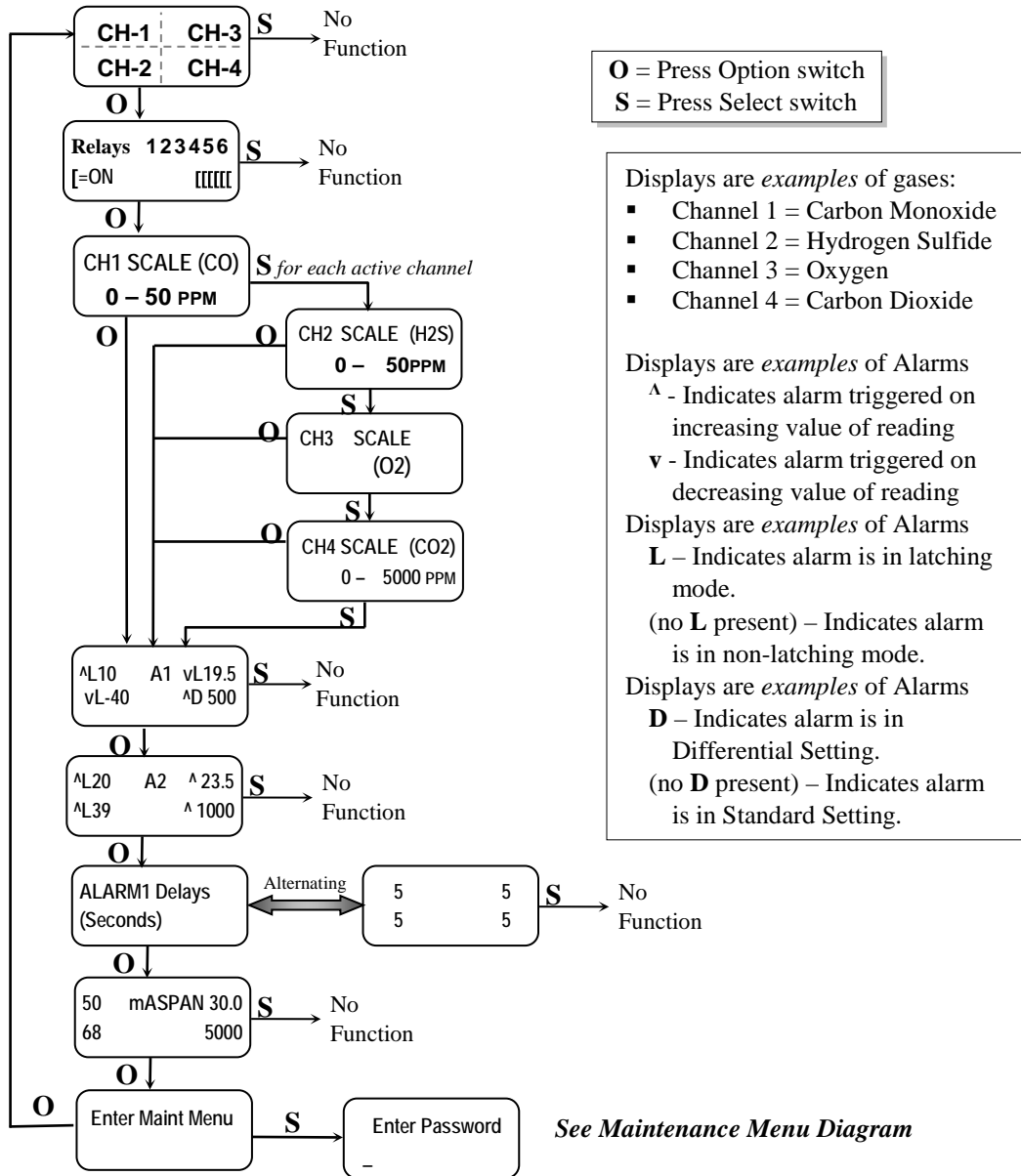

Figure 5: GSM-60 Operation Menu Flow Chart

4.7 Fault Indications

4.7.1 Low Flow Indication

A flow sensor is used to furnish a low flow indication. When the sample air pressure drops below preset levels, the fault light and audio alarm are activated, and the display flashes “Low Flow Alarm”. If two sampling hoses are connected to one **GSM-60**, the flow sensor can only detect a total flow fault condition. For example: a pump failure or both sampling hoses being blocked. The system cannot detect a flow fault if only one of the two sampling hoses is blocked.

4.7.2 Other Fault Indications

Other fault indications are associated with sensor zero and calibration activities, and are described in the maintenance **Section 5.0** of this manual.

4.8 Hydrocarbon Sensor Response

If a Hydrocarbon (HC) sensor is supplied with the **GSM-60** instrument, it is designed to detect hydrocarbon gases and vapors with an ionization potential (IP) of 10.6 eV or less. Hydrocarbons with an IP of greater than 10.6 eV will NOT be detected. Please see Appendix B for a list of common gases and vapors and their respective IP rating. Unless otherwise noted Isobutylene is used as a calibration and reference gas.

5.0 Maintenance

The **GSM-60** requires periodic sensor calibration and replacement. Calibration of toxic gas and oxygen sensor should be performed immediately following installation, one month after installation and every 3 months thereafter. HC sensor should be calibrated monthly. Oxygen and CO sensor have an estimated lifetime of 1 – 2 years. The CO2 sensor has an estimated lifetime of 3 years. Other sensors vary. Sensors should be replaced when they will not calibrate or shortly before the end of the estimated lifetime.



5.1 Cleaning Instructions

CAUTION: Never spray a cleaning solution on the surfaces of the **GSM-60** devices.

Clean the exterior of the **GSM-60** enclosures with a mild soap solution on a clean, damp cloth. Do not soak the cloth with solution so that moisture drips onto, or lingers on, external surfaces.
Under no circumstances should organic solvents such as paint thinner be used to clean instrument surfaces.

5.2 Maintenance Menu

5.2.1 Accessing Maintenance Menu

The **GSM-60** maintenance menu is accessed by entering the proper password with the **OPTION** and **SELECT** switches. See **Section 5.2.2 Figure 6** for full Maintenance Menu flow chart.

Entrance to the maintenance menu is guarded with a four-digit Password. The factory default setting of the password is 1270. When a valid numerical password is inserted, the user can enter the maintenance menu.

To enter the maintenance menu. Press the **OPTION** switch until “Enter Maint Menu” is displayed then press **SELECT** switch for the Enter Password menu. Enter the valid password as described below.

In the "Enter Maint Menu" position

- Press the **SELECT** switch "Enter Password 0" is displayed. Press **SELECT** switch once, to move cursor to next digit, this will be the first digit of the password.
- In the 000 position, the underline cursor is under the left digit.
- Press the **OPTION** switch to change the left digit; select the correct digit.
- Press the **SELECT** switch, which locks the digit in place and moves the cursor one digit to the right.

Continue this process until the four-digit password is complete. When a valid password is inserted in this manner, the display is transferred to the "Calibration" portion of the menu. If an invalid password is inserted, you are returned to the Enter Maint Menu display.



Example: Password Display (with factory installed password entered) and Flow Chart below.

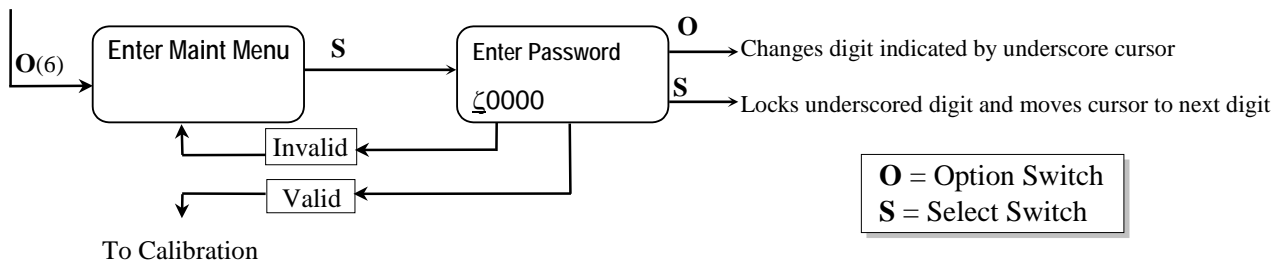

See **Section 5.2.2 Figure 6** for full Maintenance Menu flow chart.

5.2.2 Maintenance Menu Flow Chart

The maintenance menu diagram is shown in **Figure 6 Maintenance Menu Flow Chart**. From the operational display, press the **OPTION** switch 6 times; "Enter MAINTENANCE Menu" is displayed.

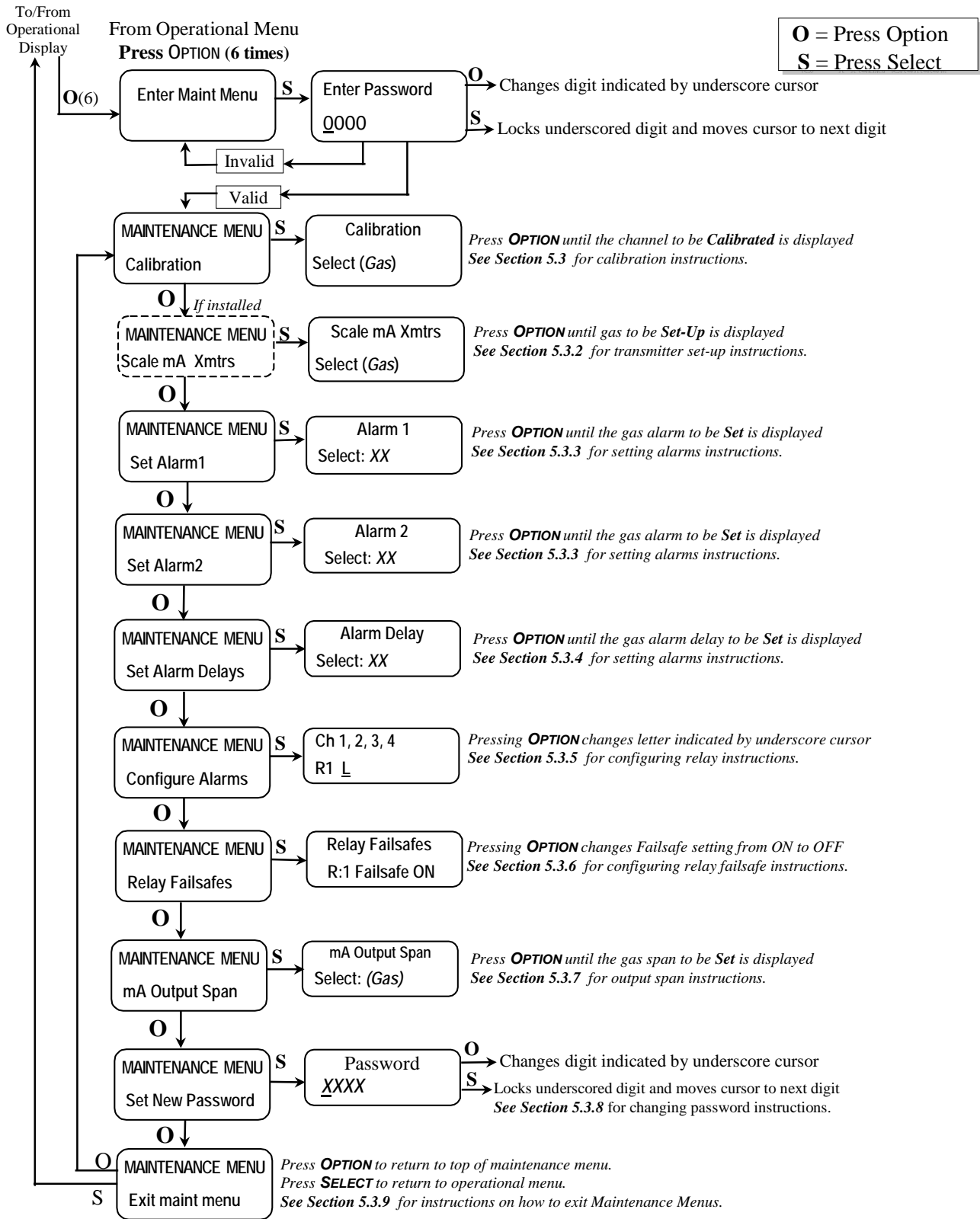

Figure 6: GSM-60 Maintenance Menu Flow Chart.

5.3 Calibration for CO, O₂, HC and CO₂ (Gas Channels)

Calibration is the process of setting the instrument up to read accurately when exposed to a target gas. This is a two-step process. A Low Calibration sets clean air reference point and the High Calibration function sets the sensitivity of the instrument. Calibration equipment is available from **ENMET** to calibrate the **GSM-60**. A list of needed material is in Section 7.0. A calibration adapter will have a fitting for the gas cylinder on one side, and a quick-disconnect to attach to the instrument on the other.

You may exit the calibration section, at any time, by *pressing and holding* the **OPTION** switch for 3 seconds, if entering calibration section by mistake or calibration gas is not available.

Wait 24 hours after initially supplying air and power to the **GSM-60** sensor before initial calibration. It is not necessary to open the Front Panel to make adjustment. The calibration functions are operated through the **OPTION** and **SELECT** switches on the front panel.

After entering a valid password to maintenance menu, see **Section 5.2.1**, the calibration section is the first menu section; enter by pressing the **SELECT** switch.

Supply sensor with clean air for Low Cal/Zero Cal setting and apply calibration gas for Hi Cal/Span Gas setting.

- Press the **SELECT** switch "Calibration Select XX" is displayed. XX = the gas to be calibrated
 - Press the **OPTION** switch, if needed, to change to the gas to be calibrated.
 - Press the **SELECT** switch, the gas & current reading is displayed in upper portion of display. The mV reading & "Low Cal 0" is displayed in the lower portion of display. This is the Low Cal setting, *usually zero*, clean air must be supplied to the sensor. This reading needs to be at or near zero. If it is not, then a cylinder of clean 20.9 air should be used. See Figure 7 if this is required.
 - Press the **SELECT** switch, that moves the cursor one digit to the right when the last digit is accepted the display will move to "Hi Cal xx" gas calibration. xx = the level of gas to be used for calibration. The mV reading is shown in the upper right hand corner of the display.
 - Apply calibration gas to sensor. See **Figure 7**. After about 1 minute and mV reading has stabilized.
 - Press the **SELECT** switch, that moves the cursor one digit to the right, when the last digit is accepted and the calibration is successful the display will momentarily show Cal OK then slope and off set readings, before returning to the Calibration Menu
- Repeat above steps for each channel to be calibrated.

NOTE: Instruments equipped with an oxygen sensor programmed with a range of 0 to 15% by volume require 99.999 % Nitrogen (**ENMET** part number 03295-100) be used for the Low Cal/Zero Cal setting and 5% by volume Oxygen (**ENMET** part number 03296-050) be used for Hi Cal/Span setting

To continue to next section, Press the **OPTION** switch.

- Press **OPTION** switch until "Exit Maint Menu" appears and then press **SELECT** switch to return the instrument to the Operational Display

Example: Full Calibration Flow Chart, for CO
From Valid Password Entry

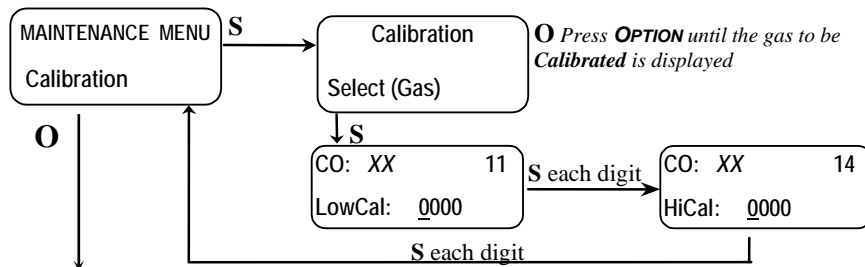

Default Calibration Points

Gas	Low Cal	Hi Cal
CO	0	20
O2	N/A*	20.9*
CO2	0	1000
HC	0	10

O = Press Option
S = Press Select

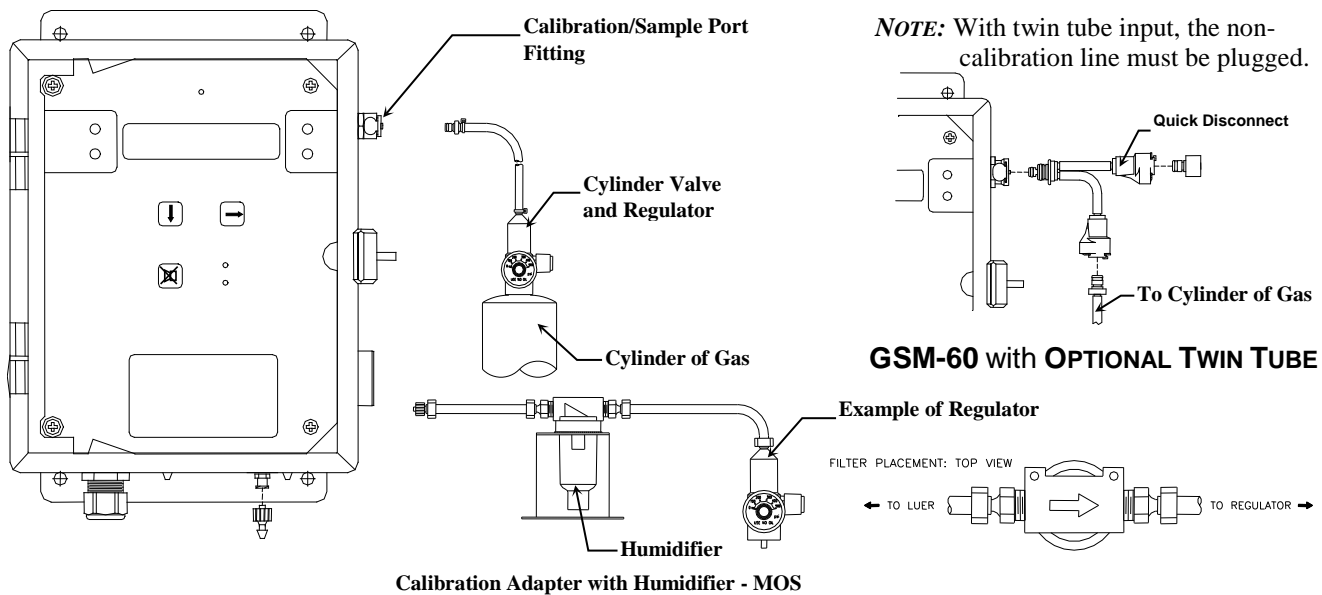

Figure 7: GSM-60 Calibration Connections

Calibration Process for MOS Sensors

The following calibration procedure must be followed whenever a 60-series part number appear in the part number of the instrument, *examples* 04652-6200-0000, 04652-7083-6000

Humidification is required when calibration is performed. In addition to the standard flow demand regulator, cylinder of calibration gas you need **ENMET** humidifier assembly part number 037000-000

- Fill the humidifier with clean water to about $\frac{3}{4}$ full, connect the flow demand regulator to one side of the humidifier and connect the other side of the humidifier to the **GSM-60** calibration/sampling port.

Warning: Be sure that the flow direction is correct, *note the arrow on the humidifier*, failure to do so will cause damage to the **GSM-60** instrument

- With the cylinder regulator and humidifier assembled follow the above steps to complete the calibration process

5.3.1A Low Cal/Zero Cal Adjust

A Low-Cal function should be performed only when the **GSM-60** sensors are exposed to clean uncontaminated air. Use a cylinder of 20.9% oxygen to provide a clean air reference if necessary. Attach the cylinder to the calibration adapter, attach the adapter to the instrument and allow gas to flow over the sensor for up to 4 minutes.

Enter the maintenance menu by repeatedly pressing **OPTION** switch, until the maintenance menu is displayed. See **Figure 6, GSM-60 Maintenance Menu** flow chart.

The first menu available is the Low Cal/Zero Cal.

Press the **SELECT** switch 4 times to perform a Low Cal.

- *If the Low Cal/Zero Cal is successful*, the display will change to Hi Cal/Span Gas. If you wish to Hi Cal/Span Gas the sensor apply calibration gas. **Proceed to gas calibration Section 5.3.1B**
- If you wish to Exit the maintenance menu, Press and *hold* **OPTION** switch until the Maintenance Menu is displayed then release. Then press **OPTION** switch until “Exit Maint Menu” appears and then press **SELECT** switch to return the instrument to the Operational Display
- *If the Low Cal/Zero Cal is Not successful*, sensor is outside of safe parameters to Low Cal, a “SLP/Off Set err” will be indicated. Repeat Section 5.3.1 Low Cal/Zero Cal Adjust making sure to use a cylinder of 20.9% Oxygen.

5.3.1B High Cal/Span Gas Adjust

A High Cal/Span Gas should only be performed after a successful Low Cal/Zero Cal has been completed.

- Press the **SELECT** switch, that moves the cursor one digit to the right when the last digit is accepted the display will move to "HI Cal xx" gas calibration. xx = the level of gas to be used for calibration. The mV reading is shown in the upper right hand corner of the display.
- Apply calibration gas to sensor. See **Figure 7**. After about 1 minute and mV reading has stabilized.
- Press the **SELECT** switch, that moves the cursor one digit to the right, when the last digit is accepted and the calibration is successful the display will momentarily show Cal OK then slope and off set readings, before returning to the Calibration Menu

Repeat above steps for each channel to be calibrated.

To continue to next section, Press the **OPTION** switch.

- Press **OPTION** switch until "Exit Maint Menu" appears and then press **SELECT** switch to return the instrument to the Operational Display

5.3.2 Set 4 –20mA Transmitter Scale

This section of the maintenance menu is installed when there are 4-20mA style sensors for dew point or other gases. This function is normally performed at the factory and is not usually required to be performed in the field unless a new transmitter is installed.

After entering a valid password into maintenance menu, the Scale mA Xmtrs section is the second menu section, if it is installed, enter by pressing the **SELECT** switch

- Press the **SELECT** switch "mA Xmtr Scale: Select XX" is displayed. XX = the gas to be set up.
- Press the **OPTION** switch, if needed, to change to the gas to be set up.
- Press the **SELECT** switch, "Ch#: mAXmter: 4mA: 0000" is displayed
- Press the **SELECT** switch, that moves the cursor one digit to the right when the last digit is accepted the display move to the full-Scale mA Xmtrs menu
- Press the **SELECT** switch, "Ch#: mAXmter: 20mA: 0000" is displayed
- Press the **SELECT** switch, that moves the cursor one digit to the right when the last digit is accepted the display will return to the Scale mA Xmtrs menu
- Repeat these steps for each 4 –20mA transmitter.
- Press **OPTION** switch until "Exit Maint Menu" appears and then press **SELECT** switch to return the instrument to the Operational Display

Example: Sensor/Transmitter Set Up Flow Chart

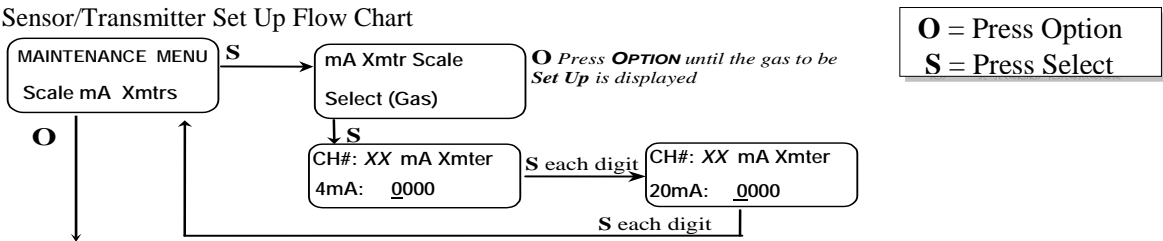

5.3.3 Set Alarm Points

Factory alarm set points are discussed in Section 4.2, See Table 1. To change the alarm points, you must enter the maintenance menu.

Entrance to the maintenance menu is guarded with a four-digit Password. The factory default setting of the password is 1270. When a valid numerical password is inserted, the user can enter the maintenance menu.

In the "Enter Maint Menu" position

- Press the **SELECT** switch "Enter Password 0" is displayed. Press **SELECT** switch once, to move cursor to next digit, this will be the first digit of the password.
- In the 000 position, the underline cursor is under the left digit.
- Press the **OPTION** switch to change the left digit; select the correct digit.
- Press the **SELECT** switch, which locks the digit in place and moves the cursor one digit to the right.

Continue this process until the four-digit password is complete. When a valid password is inserted in this manner, the display is transferred to the "Calibration" portion of the menu. If an invalid password is inserted, you are returned to the Enter Maint Menu display.

After entering a valid password:

- Press the **OPTION** switch until; "Maintenance Menu Set Alarm1" appears on display.
- Press the **SELECT** switch, "ALARM1 Select: XX" is displayed. XX = the gas of alarm point to be changed.
- Press the **OPTION** switch until, desired gas is displayed.
- Press the **SELECT** switch; "ALARM 1 V" is displayed, with the flashing placeholder underscore cursor, under the left most character, **A** for ascending trigger point or **V** for descending trigger point indicator.
- Press the **OPTION** switch to toggle between **A** and **V**; select the correct indicator.
- Press the **SELECT** switch to lock in the correct indicator. "ALARM 1 **STD**" is displayed
- Press the **OPTION** switch to toggle between **STD** and **DIFF**; select the correct indicator.
- Press the **SELECT** switch to lock in the correct indicator.

If **STD** is selected, "ALARM 1 VL " is displayed.

- The next character is the latching indicator **L** or **NOL** press the **OPTION** switch to toggle the latching mode.
 - The next character is the negative sign – press the **OPTION** switch to toggle the negative sign.
 - The next characters are the alarm 1 value, press the **OPTION** switch to select each digit of the value
- When the last digit is accepted display returns to the "Set Alarm1" position.

If **DIFF** is selected, "ALARM 1 **DIFF** A 000" is displayed.

- The next characters are the alarm 1 value, press the **OPTION** switch to select each digit of the value
 - Press the **SELECT** switch to lock in the correct character and move the cursor to the right.
 - "ALARM 1 **DIFF** **BAND** 000" is displayed, press the **OPTION** switch to select each digit of the value.
 - The next characters are the alarm 1 differential value, press the **OPTION** switch to select each digit of the value
 - Press the **SELECT** switch to lock in the correct character and move the cursor to the right.
- When the last digit is accepted, display returns to the "Set Alarm1" position.

Note: The Alarm 1 differential value is the delay of the **GSM-60** staying in alarm condition until after the measured reading has returned past the alarm point by the differential value.

Example: If the alarm set point is **A** 10 and the differential is 2, the **GSM-60** will go into alarm at 10 and stay in alarm until the reading has dropped below 8.

- Repeat for each sensor alarm 1 to be changed.
- Press the **OPTION** switch to move to alarm 2, "Set ALARM2" is displayed.
- Repeat as for alarm 1 using the **STD** section.
- Press **OPTION** switch until "Exit Maint Menu" appears, then press **SELECT** switch to return the instrument to the Operational Display

Example: Set Alarms Flow Chart

Displays are *examples* of Alarms

Λ - Indicates alarm triggered on increasing value of reading

v - Indicates alarm triggered on decreasing value of reading

L- Indicates alarm is set for latching

NOL- Indicates alarm is set for non-latching

STD – Indicates alarm in standard setting, can be set in latched or non-latched mode

DIFF – Indicates alarm in differential setting, instrument will stay in alarm beyond the alarm set point by the differential value

O = Press Option
S = Press Select

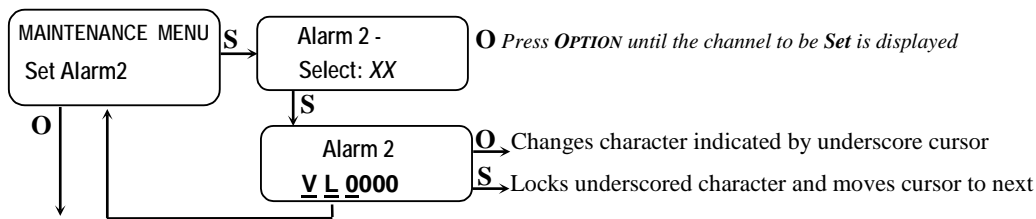
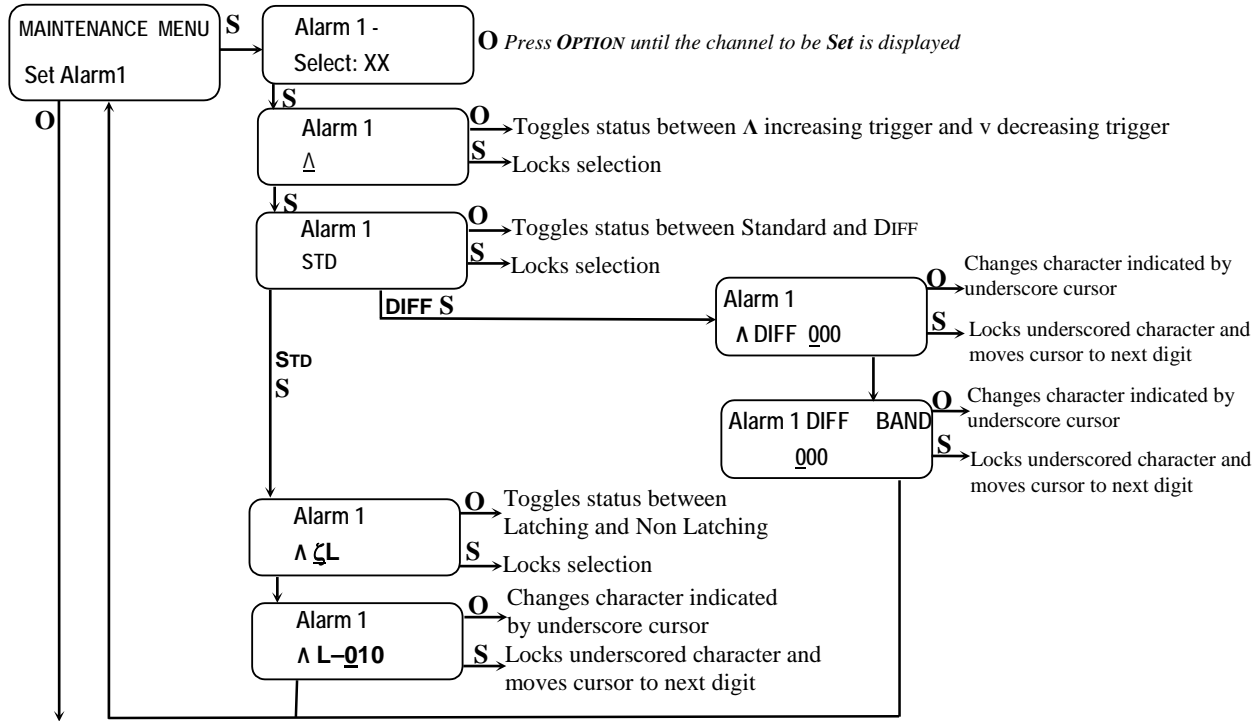

See Section 4.2 Table 3 for factory alarm set points.

5.3.4 Set Alarm Delay

The alarms may be set to delay by 1 second increments, up to 255 seconds. Alarm delays are factory set to 5 seconds. To change an alarm delay, you must enter the maintenance menu. Press the **OPTION** switch until “Enter Maint Menu” is displayed then press **SELECT** switch for the Enter Password menu. Enter the valid password as described in **Section 5.2.1**.

See **Table 4** below for factory set delays. A space is provided to record changes.

After entering a valid password:

- Press the **OPTION** switch until; “Maintenance Menu Set Alarm Delay” appears on display.
- Press the **SELECT** switch, "ALARM Delay Select: XX" is displayed. *XX* = the gas alarm to be changed.
- Press the **OPTION** switch until, desired gas is displayed.
- Press the **SELECT** switch; "ALARM Delay = 0000" is displayed, with the underscore cursor under the left digit.
- Press the **OPTION** switch to change the left digit; select the correct digit.
- Press the **SELECT** switch to lock in the correct digit and move the cursor one digit to the right. When the last digit is accepted, display returns to the "Set Alarm Delay" position.
- Repeat for each sensor alarm delay to be changed.
- Press **OPTION** switch until “Exit Maint Menu” appears and then press **SELECT** switch to return the instrument to the Operational Display

Example: Set Alarm Delay Flow Chart

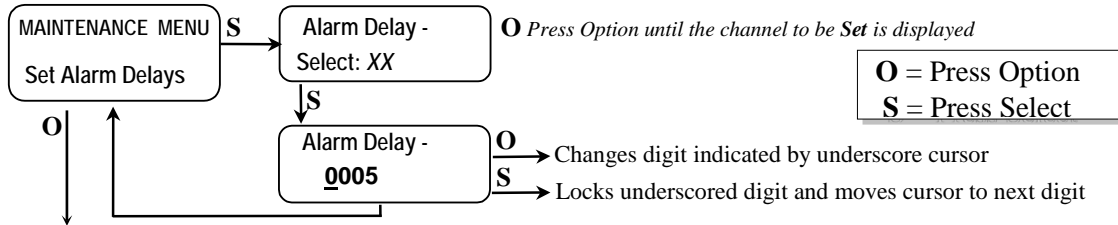

Table 4: Factory Set Gas alarms Delay

Gas	Delay	
CO	5 sec	
H ₂ S	5 sec	
O ₂	5 sec	
CO ₂	5 sec	

5.3.5 Relay Configuration

To change a relay configuration, you must enter the maintenance menu. Press the **OPTION** switch until “Enter Maint Menu” is displayed then press **SELECT** switch for the Enter Password menu. Enter the valid password as described below.

In the "Enter Maint Menu" position

- Press the **SELECT** switch "Enter Password 0" is displayed. Press **SELECT** switch once, to move cursor to next digit, this will be the first digit of the password.
- In the 000 position, the underline cursor is under the left digit.
- Press the **OPTION** switch to change the left digit; select the correct digit.
- Press the **SELECT** switch, which locks the digit in place and moves the cursor one digit to the right.

Continue this process until the four-digit password is complete. When a valid password is inserted in this manner, the display is transferred to the "Calibration" portion of the menu. If an invalid password is inserted, you are returned to the Enter Maint Menu display.

After entering a valid password:

- Press the **OPTION** switch until “Configure Alarms” is displayed
- Press the **SELECT** switch to enter the Configure Alarms menu
- Press the **OPTION** switch to set relay configuration as needed, see below for indications
- **L** = Low Alarm, **H** = High Alarm, **B** = Both Alarms, = No Relay linked to channel
- Press the **SELECT** switch to lock setting and move to next, channel and relay
- Press **OPTION** switch until “Exit Maint Menu” appears and then press **SELECT** switch to return the instrument to the Operational Display

Example: Set Relay Configuration Flow Chart

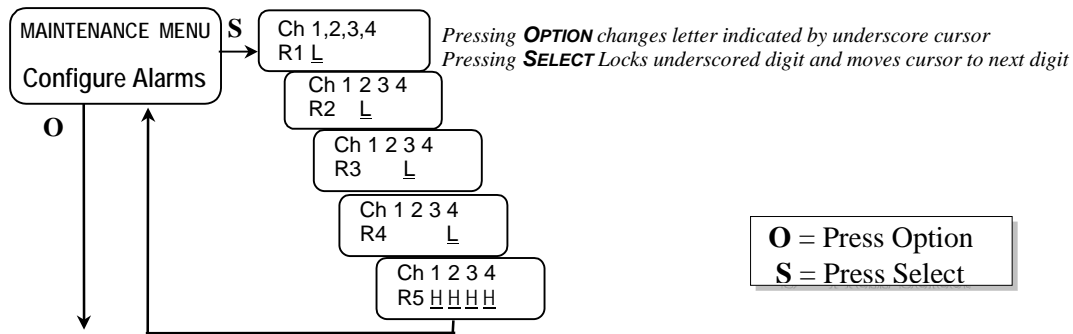

The table below shows the default relay links.

	Channel 1	Channel 2	Channel 3	Channel 4
Relay 1	Low Alarm			
Relay 2		Low Alarm		
Relay 3			Low Alarm	
Relay 4				Low Alarm
Relay 5	High Alarm	High Alarm	High Alarm	High Alarm

Relays can be linked to specific alarms.

NOTE: Each operating channel must be linked to at least 1 relay.

5.3.6 Failsafe Configuration

To change a relay failsafe configuration, you must enter the maintenance menu. Press the **OPTION** switch until “Enter Maint Menu” is displayed then press **SELECT** switch for the Enter Password menu. Enter the valid password as described below.

In the "Enter Maint Menu" position

- Press the **SELECT** switch "Enter Password 0" is displayed. Press **SELECT** switch once, to move cursor to next digit, this will be the first digit of the password.
- In the 000 position, the underline cursor is under the left digit.
- Press the **OPTION** switch to change the left digit; select the correct digit.
- Press the switch, which locks the digit in place and moves the cursor one digit to the right. Continue this process until the four-digit password is complete. When a valid password is inserted in this manner, the display is transferred to the "Calibration" portion of the menu. If an invalid password is inserted, you are returned to the Enter Maint Menu display.

After entering a valid password:

- Press the **OPTION** switch until “Relay Failsafes” is displayed
- Press the **SELECT** switch to indicate relay to be set.
- Press the **OPTION** switch to set relay indicated, On or Off as appropriate.
- Press the **SELECT** switch to cycle through each of the 5 relays, return to “Maintenance Menu Relay Failsafes”
- Press **OPTION** switch until “Exit Maint Menu” appears and then press **SELECT** switch to return the instrument to the Operational Display

Example: Set Relay Failsafe Configuration Flow Chart

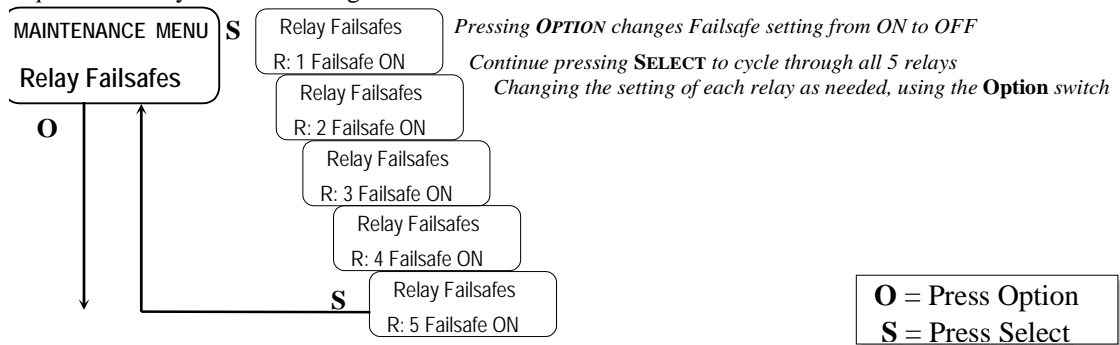

5.3.7 Set Output Span Range

To change 4-20 mA output range. This range is set at the factory and should not be changed, contact **ENMET** for information.

- Press the **OPTION** switch to continue to next section of maintenance menu.
- Press **OPTION** switch until “Exit Maint Menu” appears and then press **SELECT** switch to return the instrument to the Operational Display

Example: Set Output Span Flow Chart

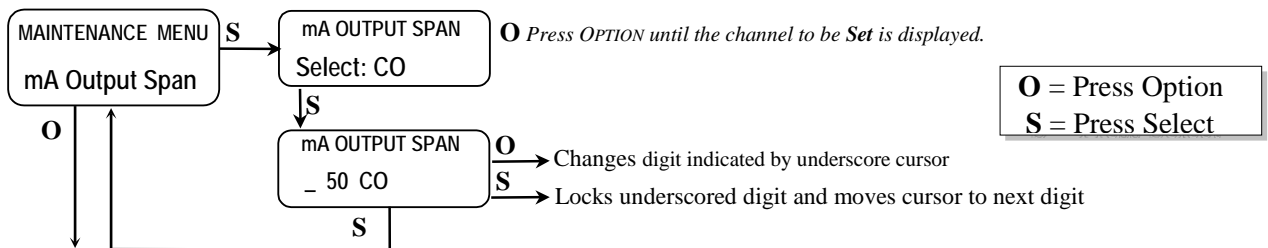

5.3.8 Set New Password

To change the password, you must enter the maintenance menu. Press the **OPTION** switch until “Enter Maint Menu” is displayed then press **SELECT** switch for the Enter Password menu. Enter the valid password as described in Section 5.2.1.

To set a new password, after inserting a valid password,

- Press the **OPTION** switch until; "Set New Password" is displayed.
- Press the **SELECT** switch; "Password 1270" is displayed, with the underscore cursor under the left digit.
- Use the **OPTION** switch to change the left digit, when the desired digit is displayed.
- Press the **SELECT** switch to lock the digit in place and move the cursor one digit to the right.

When all four digits of the new password have been selected, "Set New Password" is displayed.

Record the new password; without it, the maintenance menu cannot be reentered once you exit the Maintenance Menu. If the password is lost, call **ENMET** customer service personnel.

From the "Password XXXX" position,

- Press the **SELECT** switch to return to Set New Password section.
- Press the **OPTION** switch; to continue to "exit MAINTENANCE Menu"

Example: Set Password Flow Chart

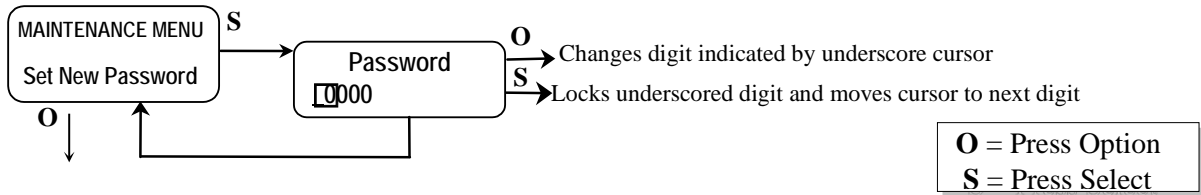

5.3.9 Exit Maintenance Menu

From the "exit MAINTENANCE Menu" position

- Press the **SELECT** switch to resume the operational display.
- Press the **OPTION** switch to reenter the maintenance menu at the "Calibration" position.

Example: Exit Maintenance Menu Flow Chart

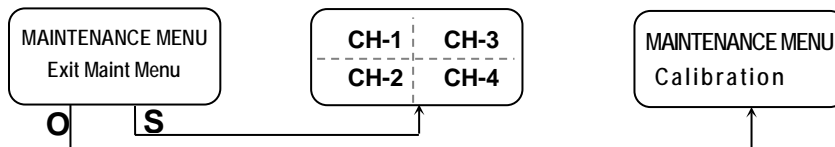

5.4 Sensor Replacement

5.4.1 Gas/Oxygen Sensor

A Gas sensor must be replaced when it can no longer be calibrated. To replace a sensor, perform the following steps.

- Turn off the electrical power. The sample air can continue to flow.
- Open the display panel and remove the four manifold retention screws and remove the manifold. See **Figure 9**.
- Remove the old sensor, and replace it with a new sensor. It is recommended that the sensor gasket/manifold also be checked and potentially replaced at the time the sensor is replaced.

CAUTION: Some new sensors come with a shorting clip that must be removed before installation, for proper operation. See **Figure 8**.

- Replace the manifold.
- Turn on the electrical power.

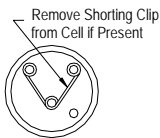

Bottom View of Sensor

Figure 8: Shorting Clip

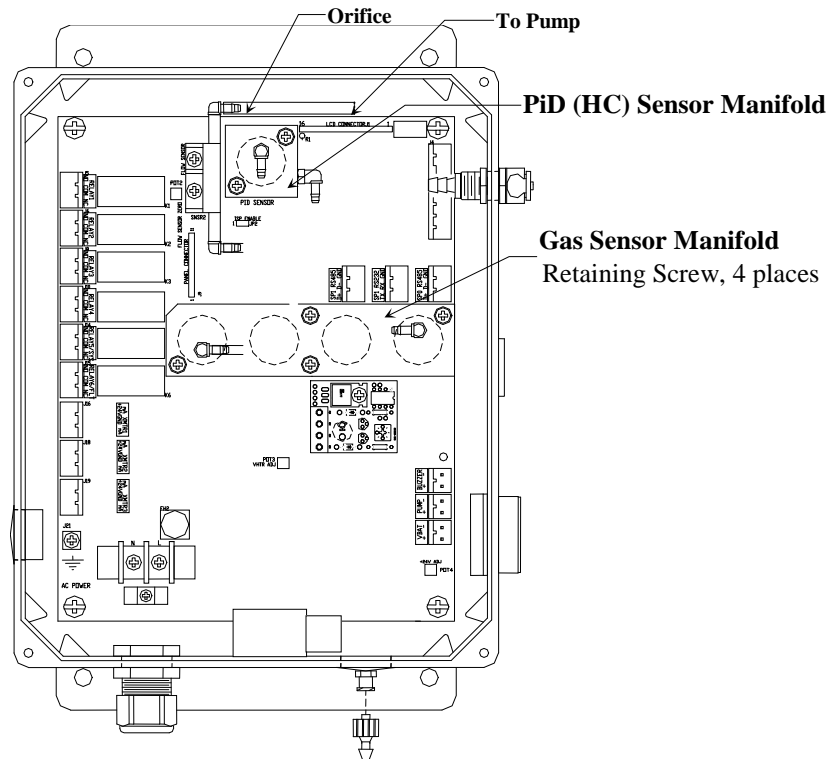

Figure 9: Location of Gas Sensor and PiD (HC) Manifolds

5.4.2 Calibration/Sensor Replacement

Sensor replacement requires that a Factory Calibration be performed. Factory Calibration allows the instrument to properly set operational parameters for each sensor.

Calibration is the process of setting the instrument up to read accurately when exposed to a target gas. This is a two-step process. A Low Calibration sets clean air reference point and the High Calibration function sets the sensitivity of the instrument.

Calibration equipment is available from **ENMET** to calibrate the **GSM-60**. A list of needed material is in Section 7.0. A calibration adapter will have a fitting for the gas cylinder on one side, and a quick-disconnect to attach to the instrument on the other.

You may exit the calibration section, at any time, by *pressing and holding* the **OPTION** switch for 3 seconds, if entering calibration section by mistake or calibration gas is not available.

Wait 24 hours after initially supplying air and power to the **GSM-60** sensor before initial calibration. It is not necessary to open the Front Panel to make adjustment. The calibration functions are operated through the **OPTION** and **SELECT** switches on the front panel.

After entering a valid password to maintenance menu, see **Section 5.2.1**, the calibration section is the first menu section; enter by pressing the **SELECT** switch.

Supply sensor with clean air for Low Cal/Zero Cal setting and apply calibration gas for Hi Cal/Span Gas setting.

- Press the **SELECT** switch "Calibration Select XX" is displayed. XX = the gas to be calibrated
- Press and *Hold* the **OPTION** switch, until the letter F appears in the upper right hand corner of the display. The F indicates that the instrument is in the Factory Calibration Mode.
- Press the **OPTION** switch, if needed, to change to the gas to be calibrated.
- Press the **SELECT** switch, the gas & current reading is displayed in upper portion of display. The mV reading & "Low Cal 0" is displayed in the lower portion of display. This is the Low Cal setting, *usually zero*, clean air must be supplied to the sensor. This reading needs to be at or near zero. If it is not, then a cylinder of clean 20.9 air should be used. See Figure 7 if this is required.
- Press the **SELECT** switch, that moves the cursor one digit to the right when the last digit is accepted the display will move to "Hi Cal xx" gas calibration. xx = the level of gas to be used for calibration. The mV reading is shown in the upper right hand corner of the display.
- Apply calibration gas to sensor. See **Figure 7**. After about 1 minute and mV reading has stabilized.
- Press the **SELECT** switch, that moves the cursor one digit to the right, when the last digit is accepted and the calibration is successful the display will momentarily show Cal OK then slope and off set readings, before returning to the Calibration Menu

Repeat above steps for each channel to be calibrated.

NOTE: Instruments equipped with an oxygen sensor programmed with a range of 0 to 15% by volume require 99.999 % Nitrogen (*ENMET* part number 03295-100) be used for the Low Cal/Zero Cal setting and 5% by volume Oxygen (*ENMET* part number 03296-050) be used for HI Cal/Span setting

To continue to next section, Press the **OPTION** switch.

- Press **OPTION** switch until "Exit Maint Menu" appears and then press **SELECT** switch to return the instrument to the Operational Display

Example: Full Calibration Flow Chart, for CO
From Valid Password Entry

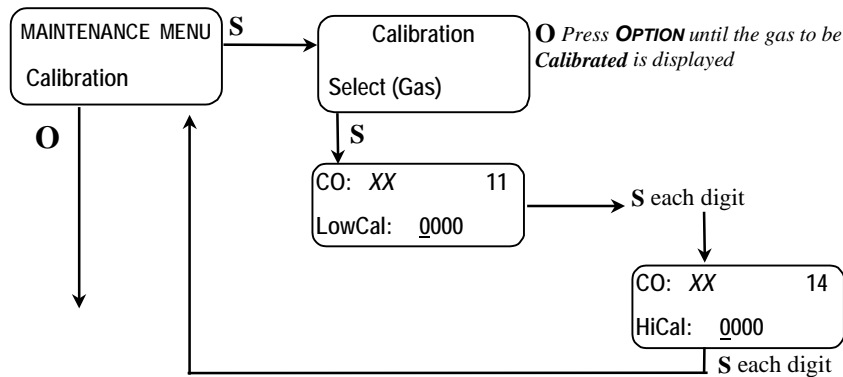

Default Calibration Points

Gas	Low Cal	Hi Cal
CO	0	20
O2	N/A*	20.9*
CO2	0	1000
HC	0	10

O = Press Option
S = Press Select

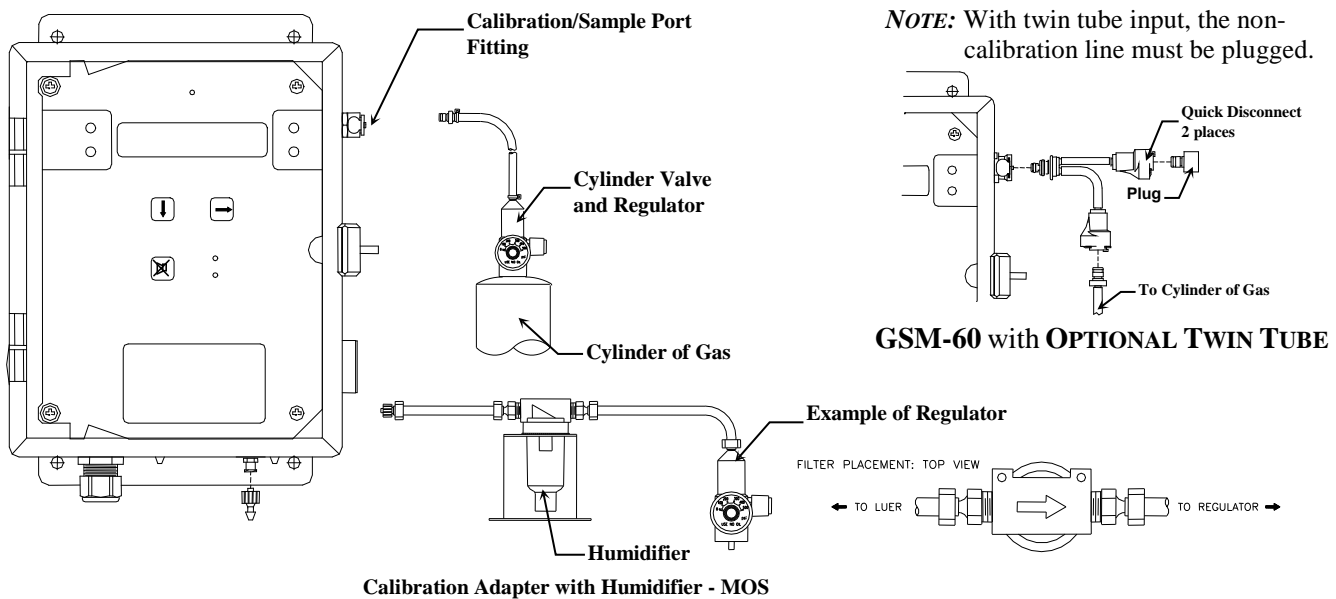

Figure 7: GSM-60 Calibration Connections

Calibration Process for MOS Sensors

The following calibration procedure must be followed whenever a 60-series part number appear in the part number of the instrument, *examples* 04652-6200-0000, 04652-7083-6000

Humidification is required when calibration is performed. In addition to the standard flow demand regulator, cylinder of calibration gas you need **ENMET** humidifier assembly part number 037000-000

- Fill the humidifier with clean water to about $\frac{3}{4}$ full, connect the flow demand regulator to one side of the humidifier and connect the other side of the humidifier to the **GSM-60** calibration/sampling port.

Warning: Be sure that the flow direction is correct, *note the arrow on the humidifier*, failure to do so will cause damage to the **GSM-60** instrument

- With the cylinder regulator and humidifier assembled follow the above steps to complete the calibration process

5.4.3A Low Cal/Zero Cal Adjust

A Low Cal function should be performed only when the **GSM-60** sensors are exposed to clean uncontaminated air. Use a cylinder of 20.9% oxygen to provide a clean air reference if necessary. Attach the cylinder to the calibration adapter, attach the adapter to the instrument and allow gas to flow over the sensor for up to 4 minutes.

Enter the maintenance menu by repeatedly pressing **OPTION** switch, until the maintenance menu is displayed. See **Figure 6, GSM-60** Maintenance Menu flow chart.

The first menu available is the Low Cal/Zero Cal.

Press the **SELECT** switch 4 times to perform a Low Cal.

- *If the Low Cal/Zero Cal is successful*, the display will change to Hi Cal/Span Gas. If you wish to Hi Cal/Span Gas the sensor apply calibration gas. **Proceed to gas calibration Section 5.3.1B**
- If you wish to Exit the maintenance menu, Press and *hold* **OPTION** switch until the Maintenance Menu is displayed then release. Then press **OPTION** switch until “Exit Maint Menu” appears and then press **SELECT** switch to return the instrument to the Operational Display
- *If the Low Cal/Zero Cal is Not successful*, sensor is outside of safe parameters to Low Cal, a “SLP/Off Set err” will be indicated. Repeat Section 5.3.1 Low Cal/Zero Cal Adjust making sure to use a cylinder of 20.9% Oxygen.

5.4.3B High Cal/Span Gas Adjust

A High Cal/Span Gas should only be performed after a successful Low Cal/Zero Cal has been completed.

- Press the **SELECT** switch, that moves the cursor one digit to the right when the last digit is accepted the display will move to "Hi Cal *xx*" gas calibration. *xx* = the level of gas to be used for calibration. The mV reading is shown in the upper right hand corner of the display.
- Apply calibration gas to sensor. See **Figure 7**. After about 1 minute and mV reading has stabilized.
- Press the **SELECT** switch, that moves the cursor one digit to the right, when the last digit is accepted and the calibration is successful the display will momentarily show Cal OK then slope and off set readings, before returning to the Calibration Menu

Repeat above steps for each channel to be calibrated.

To continue to next section, Press the **OPTION** switch.

- Press **OPTION** switch until "Exit Maint Menu" appears and then press **SELECT** switch to return the instrument to the Operational Display

5.5 Flow Control Orifice

A 0.0225-inch diameter orifice is used to set the flow rate. In well-maintained medical air systems, this orifice should not clog. However, if difficulty is experienced in maintaining flow rate examine this orifice; replace it if necessary.

Orifice location will depend on instrument sensor configuration.

6.0 Technical Data and Specifications

NOTE: All specifications stated in this manual may change without notice.

Electrical Power	15 Amp fused branch circuit		
	100-240 VAC		
	0.9 A		
	50/60 Hz		
	Board Mounted Fuse FH2, 0.630A, 5 x 20mm		
Storage and Transport	Temperature:	-20° to +60°C (-4° to +140°F)	
	<i>preferred</i>	0° to +20°C (32° to 68°F)	
	Relative Humidity	0 - 99% RH, non-condensing	
	Atmospheric Pressure	20 to 36 inHg (68 to 133 kPa)	
Operation	Temperature:	0° to +40°C (32° to +104°F)	
	Relative Humidity	0 - 99% RH, non-condensing	
	Atmospheric Pressure	20 to 36 inHg (68 to 133 kPa)	
Mechanical	Dimensions:	11 x 9 x 8 inches (27.9 x 22.9 x 20.3 cm)	
	Weight:	8 lbs (3.6 kg)	
	Material:	Engineered thermoplastic with hinged front cover	
	Strain relief:	5 – 12 mm OD	
Outputs	Relays:	SPDT Resistive Load Inductive Load 10A at 110 VAC 7.5A at 110 VAC 10A at 30 VDC 5A at 30 VDC	
	Analog:	4-20 mA x 3	
	Digital:	RS-232 – Modbus RS-485 – Modbus	
	Audio:	95 db at 2 ft	
Examples of Sensors	Type	Range	*Typical Response Time
	CO	0 – 50 ppm	T ₉₀ = 30 seconds
	O ₂	0 – 30%	T ₉₀ = 15 seconds
	CO ₂	0 – 5000 ppm	T ₉₀ = 30 seconds
	HC	0 – 100 ppm	T ₉₀ = 30 seconds
	Others	Contact ENMET	

NOTE: Response time is dependent on sampling length.

7.0 Replacement Part Numbers

7.1 ENMET part numbers for sensors and replacement parts:

Part number	Description
03053-000	Sensor, CO2
67025-1114	Sensor, Oxygen
03015-014	Sensor, MOS 812
03016-014	Sensor, MOS 813
03028-XXX	Sensor, PID, 10.6 eV Contact <i>ENMET</i>
67025-XXXX	Sensor, Toxic Contact <i>ENMET</i>
03028-005	Sensor, Replacement lamp, PID, 10.6 eV
73540-002	Orifice
64002-1000	Fuse, 1.0 Amp 5x20mm
06008-004	Sensor Gasket
65057-011	Terminal plug, 3 position
65057-012	Terminal plug, 4 position
65057-010	Terminal plug, 2 position
73089-004	Filter Assembly, Particulate
04018-128	Pump, Replacement for instrument s/n 118 and above
04018-118	Pump, Replacement for instrument s/n 117 and below

Consult *ENMET* or your distributor for more information

7.2 ENMET part numbers for Calibration equipment:

Part number	Description
03219-020	Gas Cylinder, 20 ppm CO in air
03296-209	Gas Cylinder, 20.9% oxygen in nitrogen
03510-001	Regulator Assembly, Flow Demand CO, O ₂ (steel cylinders)
03223-1000	Gas Cylinder, 1000 ppm CO ₂ in air,
03510-002	Regulator Assembly, Flow Demand CO ₂ (aluminum cylinders)
03290-010	Gas Cylinder, 10 ppm Isobutylene in air

Consult *ENMET* or your distributor for more information

Appendix A: CO Characteristics

The Characteristics and Effects of Carbon Monoxide

Carbon monoxide is a colorless odorless toxic gas generated by incomplete combustion of a hydrocarbon fuel in air. It may be present where internal combustion engines, furnaces, boilers, and other combustion devices are present. It is toxic when inhaled because of its great affinity to hemoglobin, the oxygen carriers in the red cells of the blood. CO replaces the oxygen normally carried by the hemoglobin, and thus inhibits the delivery of oxygen throughout the body; the victim suffers from oxygen deficiency, and may die from asphyxiation. The symptoms and degree of danger resulting from exposure to CO depend upon the concentration of the gas and the length of exposure; this is shown in **Figure 10**. The **GSM-60** instrument is employed to warn the user of the presence of CO, and to facilitate the assessment of the degree of danger that he or she is exposed to.

Based upon knowledge of the effects of CO, the Occupational Safety and Health Authority (OSHA) has set limits on exposure to CO in the workplace. These are 35 ppm (parts CO per million parts air) as a time weighted average for an eight-hour day, and a maximum exposure of 200 ppm. For compressed air line applications, OSHA requires Grade D breathing air supplied, using a Compressed Gas Association (CGA) definition (G-7.1). Depending on interpretation of the OSHA respiratory standard, 10 ppm and 20 ppm CO have been used as maximum limits and standard instrument alarm points.

If a CO sensor is installed, the **GSM-60** has two preset alarm set points, at 10 ppm and 20 ppm CO, which are adjustable, but cannot be set below 5 ppm or above 50 ppm.

The curves below are for percent Carboxyhemoglobin with 50% being the top curve, 5% the bottom. %COHb is a measure of the amount of hemoglobin occupied by CO rather than oxygen. CO effects upon children, adults engaging in physical activity, and smokers, are more pronounced.

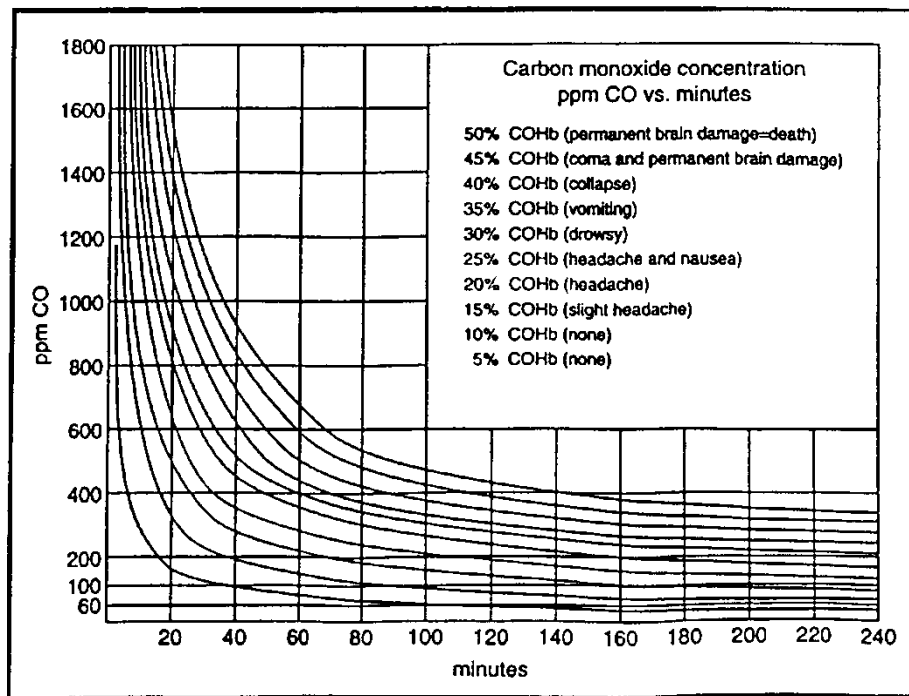

Figure 10: Carbon Monoxide Concentration

Appendix B: Gas Ionization Potentials

Chemical Name	IP (eV)
A	
2-Amino pyridine	8.00
Acetaldehyde	10.21
Acetamide	9.77
Acetic acid	10.69
Acetic anhydride	10.00
Acetone	9.69
Acetonitrile	12.20
Acetophenone	9.27
Acetyl bromide	10.55
Acetyl chloride	11.02
Acetylene	11.41
Acrolein	10.10
Acrylamide	9.50
Acrylonitrile	10.91
Allyl alcohol	9.67
Allyl chloride	9.90
Ammonia	10.20
Aniline	7.70
Anisidine	7.44
Anisole	8.22
Arsine	9.89
B	
1,3-Butadiene (butadiene)	9.07
1-Bromo-2-chloroethane	10.63
1-Bromo-2-methylpropane	10.09
1-Bromo-4-fluorobenzene	8.99
1-Bromobutane	10.13
1-Bromopentane	10.10
1-Bromopropane	10.18
1-Bromopropene	9.30
1-Butanethiol	9.14
1-Butene	9.58
1-Butyne	10.18
2,3-Butadiene	9.23
2-Bromo-2-methylpropane	9.89
2-Bromobutane	9.98
2-Bromopropane	10.08
2-Bromothiophene	8.63
2-Butanone (MEK)	9.54
3-Bromopropene	9.70
3-Butene nitrile	10.39
Benzaldehyde	9.53
Benzene	9.25
Benzenethiol	8.33
Benzonitrile	9.71
Benzotrifluoride	9.68
Biphenyl	8.27
Boron oxide	13.50
Boron trifluoride	15.56
Bromine	10.54
Bromobenzene	8.98
Bromochloromethane	10.77
Bromoform	10.48
Butane	10.63
Butyl mercaptan	9.15
cis-2-Butene	9.13
m-Bromotoluene	8.81
n-Butyl acetate	10.01
n-Butyl alcohol	10.04
n-Butyl amine	8.71
n-Butyl benzene	8.69
n-Butyl formate	10.50
n-Butyraldehyde	9.86
n-Butyric acid	10.16
n-Butyronitrile	11.67
o-Bromotoluene	8.79

Chemical Name	IP (eV)
p-Bromotoluene	8.67
p-tert-Butyltoluene	8.28
s-Butyl amine	8.70
s-Butyl benzene	8.68
sec-Butyl acetate	9.91
t-Butyl amine	8.64
t-Butyl benzene	8.68
trans-2-Butene	9.13
C	
1-Chloro-2-methylpropane	10.66
1-Chloro-3-fluorobenzene	9.21
1-Chlorobutane	10.67
1-Chloropropane	10.82
2-Chloro-2-methylpropane	10.61
2-Chlorobutane	10.65
2-Chloropropane	10.78
2-Chlorothiophene	8.68
3-Chloropropene	10.04
Camphor	8.76
Carbon dioxide	13.79
Carbon disulfide	10.07
Carbon monoxide	14.01
Carbon tetrachloride	11.47
Chlorine	11.48
Chlorine dioxide	10.36
Chlorine trifluoride	12.65
Chloroacetaldehyde	10.61
α-Chloroacetophenone	9.44
Chlorobenzene	9.07
Chlorobromomethane	10.77
Chlorofluoromethane (Freon 22)	12.45
Chloroform	11.37
Chlorotrifluoromethane (Freon 13)	12.91
Chrysene	7.59
Cresol	8.14
Crotonaldehyde	9.73
Cumene (isopropyl benzene)	8.75
Cyanogen	13.80
Cyclohexane	9.80
Cyclohexanol	9.75
Cyclohexanone	9.14
Cyclohexene	8.95
Cyclo-octatetraene	7.99
Cyclopentadiene	8.56
Cyclopentane	10.53
Cyclopentanone	9.26
Cyclopentene	9.01
Cyclopropane	10.06
m-Chlorotoluene	8.83
o-Chlorotoluene	8.83
p-Chlorotoluene	8.70
D	
1,1-Dibromoethane	10.19
1,1-Dichloroethane	11.12
1,1-Dimethoxyethane	9.65
1,1-Dimethylhydrazine	7.28
1,2-Dibromoethane	9.45
1,2-Dichloro-1,1,2,2-tetrafluoroethane (Freon 114)	12.20
1,2-Dichloroethane	11.12
1,2-Dichloropropane	10.87
1,3-Dibromopropane	10.07
1,3-Dichloropropane	10.85
2,2-Dimethyl butane	10.06
2,2-Dimethyl propane	10.35
2,3-Dichloropropene	9.82
2,3-Dimethyl butane	10.02
3,3-Dimethyl butanone	9.17
cis-Dichloroethane	9.65

Chemical Name	IP (eV)
(D continued)	
Decaborane	9.88
Diazomethane	9.00
Diborane	12.00
Dibromochloromethane	10.59
Dibromodifluoromethane	11.07
Dibromomethane	10.49
Dibutylamine	7.69
Dichlorodifluoromethane (Freon 12)	12.31
Dichlorofluoromethane	12.39
Dichloromethane	11.35
Diethoxymethane	9.70
Diethyl amine	8.01
Diethyl ether	9.53
Diethyl ketone	9.32
Diethyl sulfide	8.43
Diethyl sulfite	9.68
Difluorodibromomethane	11.07
Dihydropyran	8.34
Diiodomethane	9.34
Diisopropylamine	7.73
Dimethoxymethane (methylal)	10.00
Dimethyl amine	8.24
Dimethyl ether	10.00
Dimethyl sulfide	8.69
Dimethylaniline	7.13
Dimethylformamide	9.18
Dimethylphthalate	9.64
Dinitrobenzene	10.71
Dioxane	9.19
Diphenyl	7.95
Dipropyl amine	7.84
Dipropyl sulfide	8.30
Durene	8.03
m-Dichlorobenzene	9.12
N,N-Diethyl acetamide	8.60
N,N-Diethyl formamide	8.89
N,N-Dimethyl acetamide	8.81
N,N-Dimethyl formamide	9.12
o-Dichlorobenzene	9.06
p-Dichlorobenzene	8.95
p-Dioxane	9.13
trans-Dichloroethene	9.66
E	
Epichlorohydrin	10.20
Ethane	11.65
Ethanthiol (ethyl mercaptan)	9.29
Ethanolamine	8.96
Ethene	10.52
Ethyl acetate	10.11
Ethyl alcohol	10.48
Ethyl amine	8.86
Ethyl benzene	8.76
Ethyl bromide	10.29
Ethyl chloride (chloroethane)	10.98
Ethyl disulfide	8.27
Ethyl ether	9.51
Ethyl formate	10.61
Ethyl iodide	9.33
Ethyl isothiocyanate	9.14
Ethyl mercaptan	9.29
Ethyl methyl sulfide	8.55
Ethyl nitrate	11.22
Ethyl propionate	10.00
Ethyl thiocyanate	9.89
Ethylene chlorohydrin	10.52
Ethylene diamine	8.60
Ethylene dibromide	10.37
Ethylene dichloride	11.05
Ethylene oxide	10.57
Ethylenimine	9.20
Ethynylbenzene	8.82

Chemical Name	IP (eV)
F	
2-Furaldehyde	9.21
Fluorine	15.70
Fluorobenzene	9.20
Formaldehyde	10.87
Formamide	10.25
Formic acid	11.05
Freon 11 (trichlorofluoromethane)	11.77
Freon 112 (1,1,2,2-tetrachloro-1,2-difluoroethane)	11.30
Freon 113 (1,1,2-trichloro-1,2,2-trifluoroethane)	11.78
Freon 114 (1,2-dichloro-1,1,2,2-tetrafluoroethane)	12.20
Freon 12 (dichlorodifluoromethane)	12.31
Freon 13 (chlorotrifluoromethane)	12.91
Freon 22 (chlorofluoromethane)	12.45
Furan	8.89
Furfural	9.21
m-Fluorotoluene	8.92
o-Fluorophenol	8.66
o-Fluorotoluene	8.92
p-Fluorotoluene	8.79
H	
1-Hexene	9.46
2-Heptanone	9.33
2-Hexanone	9.35
Heptane	10.08
Hexachloroethane	11.10
Hexane	10.18
Hydrazine	8.10
Hydrogen	15.43
Hydrogen bromide	11.62
Hydrogen chloride	12.74
Hydrogen cyanide	13.91
Hydrogen fluoride	15.77
Hydrogen iodide	10.38
Hydrogen selenide	9.88
Hydrogen sulfide	10.46
Hydrogen telluride	9.14
Hydroquinone	7.95
I	
1-Iodo-2-methylpropane	9.18
1-Iodobutane	9.21
1-Iodopentane	9.19
1-Iodopropane	9.26
2-Iodobutane	9.09
2-Iodopropane	9.17
Iodine	9.28
Iodobenzene	8.73
Isobutane	10.57
Isobutyl acetate	9.97
Isobutyl alcohol	10.12
Isobutyl amine	8.70
Isobutyl formate	10.46
Isobutyraldehyde	9.74
Isobutyric acid	10.02
Isopentane	10.32
Isophorone	9.07
Isoprene	8.85
Isopropyl acetate	9.99
Isopropyl alcohol	10.16
Isopropyl amine	8.72
Isopropyl benzene	8.69
Isopropyl ether	9.20
Isovaleraldehyde	9.71
m-Iodotoluene	8.61
o-Iodotoluene	8.62
p-Iodotoluene	8.50
K	
Ketene	9.61
L	
2,3-Lutidine	8.85
2,4-Lutidine	8.85
2,6-Lutidine	8.85

Chemical Name	IP (eV)
M	
2-Methyl furan	8.39
2-Methyl naphthalene	7.96
1-Methyl naphthalene	7.96
2-Methyl propene	9.23
2-Methyl-1-butene	9.12
2-Methylpentane	10.12
3-Methyl-1-butene	9.51
3-Methyl-2-butene	8.67
3-Methylpentane	10.08
4-Methylcyclohexene	8.91
Maleic anhydride	10.80
Mesityl oxide	9.08
Mesitylene	8.40
Methane	12.98
Methanethiol (methyl mercaptan)	9.44
Methyl acetate	10.27
Methyl acetylene	10.37
Methyl acrylate	9.90
Methyl alcohol	10.85
Methyl amine	8.97
Methyl bromide	10.54
Methyl butyl ketone	9.34
Methyl butyrate	10.07
Methyl cellosolve	9.60
Methyl chloride	11.28
Methyl chloroform (1,1,1-trichloroethane)	11.00
Methyl disulfide	8.46
Methyl ethyl ketone	9.53
Methyl formate	10.82
Methyl iodide	9.54
Methyl isobutyl ketone	9.30
Methyl isobutyrate	9.98
Methyl isocyanate	10.67
Methyl isopropyl ketone	9.32
Methyl isothiocyanate	9.25
Methyl mercaptan	9.44
Methyl methacrylate	9.70
Methyl propionate	10.15
Methyl propyl ketone	9.39
□]Methyl styrene	8.35
Methyl thiocyanate	10.07
Methylal (dimethoxymethane)	10.00
Methylcyclohexane	9.85
Methylene chloride	11.32
Methyl-n-amyl ketone	9.30
Monomethyl aniline	7.32
Monomethyl hydrazine	7.67
Morpholine	8.20
n-Methyl acetamide	8.90
N	
1-Nitropropane	10.88
2-Nitropropane	10.71
Naphthalene	8.12
Nickel carbonyl	8.27
Nitric oxide, (NO)	9.25
Nitrobenzene	9.92
Nitroethane	10.88
Nitrogen	15.58
Nitrogen dioxide	9.78
Nitrogen trifluoride	12.97
Nitromethane	11.08
Nitrotoluene	9.45
p-Nitrochloro benzene	9.96
O	
Octane	9.82
Oxygen	12.08
Ozone	12.08
P	
1-Pentene	9.50
1-Propanethiol	9.20
2,4-Pentanedione	8.87

Chemical Name	IP (eV)
(P continued)	
2-Pentanone	9.38
2-Picoline	9.02
3-Picoline	9.02
4-Picoline	9.04
n-Propyl nitrate	11.07
Pentaborane	10.40
Pentane	10.35
Perchloroethylene	9.32
Pheneloic	8.18
Phenol	8.50
Phenyl ether (diphenyl oxide)	8.82
Phenyl hydrazine	7.64
Phenyl isocyanate	8.77
Phenyl isothiocyanate	8.52
Phenylene diamine	6.89
Phosgene	11.77
Phosphine	9.87
Phosphorus trichloride	9.91
Phthalic anhydride	10.00
Propane	11.07
Propargyl alcohol	10.51
Propiolactone	9.70
Propionaldehyde	9.98
Propionic acid	10.24
Propionitrile	11.84
Propyl acetate	10.04
Propyl alcohol	10.20
Propyl amine	8.78
Propyl benzene	8.72
Propyl ether	9.27
Propyl formate	10.54
Propylene	9.73
Propylene dichloride	10.87
Propylene imine	9.00
Propylene oxide	10.22
Propyne	10.36
Pyridine	9.32
Pyrrrole	8.20
Q	
Quinone	10.04
S	
Stibine	9.51
Styrene	8.47
Sulfur dioxide	12.30
Sulfur hexafluoride	15.33
Sulfur monochloride	9.66
Sulfuryl fluoride	13.00
T	
o-Terphenyls	7.78
1,1,2,2-Tetrachloro-1,2-difluoroethane (Freon 112)	11.30
1,1,1-Trichloroethane	11.00
1,1,2-Trichloro-1,2,2-trifluoroethane (Freon 113)	11.78
2,2,4-Trimethyl pentane	9.86
o-Toluidine	7.44
Tetrachloroethane	11.62
Tetrachloroethene	9.32
Tetrachloromethane	11.47
Tetrahydrofuran	9.54
Tetrahydropyran	9.25
Thiolacetic acid	10.00
Thiophene	8.86
Toluene	8.82
Tribromoethene	9.27
Tribromofluoromethane	10.67
Tribromomethane	10.51
Trichloroethene	9.45
Trichloroethylene	9.47
Trichlorofluoromethane (Freon 11)	11.77
Trichloromethane	11.42
Triethylamine	7.50
Trifluoromonobromo-methane	11.40

Chemical Name	IP (eV)
(T continued)	
Trimethyl amine	7.82
Tripropyl amine	7.23
V	
o-Vinyl toluene	8.20
Valeraldehyde	9.82
Valeric acid	10.12
Vinyl acetate	9.19
Vinyl bromide	9.80
Vinyl chloride	10.00
Vinyl methyl ether	8.93

Chemical Name	IP (eV)
W	
Water	12.59
X	
2,4-Xylidine	7.65
m-Xylene	8.56
o-Xylene	8.56
p-Xylene	8.45

Notes:

8.0 Terms and Conditions

8.1 Ordering Information

Address orders to:

ENMET
Attention: Customer Service Department
680 Fairfield Court
Ann Arbor, MI 48108

Email Orders: orderentry@enmet.com

Phone: 734-761-1270

Fax: 734-761-3220

You may also contact our customer service department by email info@enmet.com. MINIMUM ORDER IS \$50.00.

8.2 Delivery

Unless Seller otherwise specifies, delivery will be made: FOB Ann Arbor, MI and/or FOB Bowling Green, KY. Title and risk of loss shall pass to Buyer at that point. Shipping and handling charges will be Prepaid and Added to Buyer's invoice. Buyer may request shipping be charged to their own account with a preferred carrier. Seller shall have the right to choose means of transportation and to route shipment when specific instructions are not included with Buyer's order. Seller agrees to deliver the goods and services, within the time, in accordance with specifications, at the prices specified on the face hereof. Buyer's orders to this quotation are not subject to cancellation or deferment of delivery without indemnification of loss to the Seller resulting therefrom. Seller shall not be liable to Buyer for any loss or damage sustained on account of this delay or nonperformance due to causes beyond Seller's control and without his fault or negligence. Where performance of the terms here is contingent upon timely delivery of goods or services by the Buyer and such delivery is in default, Seller shall be indemnified for any damage or loss resulting therefrom, and/or by extension of Seller's delivery commitment, as applicable.

8.3 Payment Terms

Payment Terms are Net 30 Days from the date of shipment from Seller unless otherwise noted. All shipping and handling costs will be charged to Buyer on a Prepaid and Add basis. Buyer has the option of paying for shipping by charging its own account with a carrier

8.4 Warranty Information and Guidelines

The Seller warrants new instruments to be free from defects in workmanship and material under normal use for a period of one year from date of shipment. The warrant covers both parts and labor excluding calibration and expendable parts such as filters, detector tubes, batteries, etc. If the inspection by the Seller confirms that the product is defective, it will be repaired or replaced at no charge, within the stated limitations, and returned prepaid to any location in the United States. The Seller shall not be liable for any loss or damage caused by the improper use or installation of the product. The Buyer indemnifies and saves harmless the Seller with respect to any loss or damages that may arise through the use by the Buyer or others of this equipment. This warranty is expressly given in lieu of all other warranties, either expressed, implied or statutory, including that of merchantability, and all other obligations, or liabilities of ENMET, LLC for damages arising out of or in connection with the use or repair or performance of the product. In no event shall ENMET, LLC, be liable for any indirect, incidental, special or consequential damages or for any delay in the performance by ENMET, LLC, which may arise in connection with this equipment. ENMET neither assumes nor authorizes any representatives or other persons to assume for it any obligation or liability other than that which is set forth herein. Buyer agrees to indemnify and save harmless Seller for any damage or loss from lawsuits against Seller by reason of manufacture of sale of materials, parts, or use of processes resulting from Buyer's design specifications. Any patent, design, pattern, tool, die, jig, fixture, drawing, test equipment, or process furnished by Seller; whether possessed by the Seller before the date of this quotation, or devised or acquired by Seller during performance of the terms of this quotation, shall remain the property of the Seller except by specific stipulation on the face hereof. Seller reserves the right, without liability, for damage or loss, to destroy Buyer's drawings, specifications, patterns and special tools supplied by Buyer for performance of the terms on the face hereof, unless Buyer gives notice of the disposition of such items.

8.5 Return Policy

All returns for credit must be approved in advance by ENMET, LLC. Such returns are subject to a minimum \$50.00 or 20% restocking charge, whichever is greater. **Approval of equipment for return is totally at the discretion of ENMET, LLC.** All requests for return/exchange must be made no later 30 days of the original shipping date from ENMET. The actual amount of any resulting credit will not be determined prior to a complete inspection of the equipment by ENMET. Calibration gas cylinders cannot be returned or restocked.

9.0 Instructions for Returning an Instrument for Service

Contact the ENMET Service Department for all service requests.

Phone: 734-761-1270

Email: repair@enmet.com

Fill out the “Service Request Form” found at the end of this manual and return with your instrument for all needs. Please send your instrument for service to the site in which the product was purchased. A new “Service Request Form” may be requested if the one found in the manual is not available. All instruments should be shipped prepaid to ENMET.

Address for Service:

Michigan Location:

ENMET
Attention: Service Department
680 Fairfield Court
Ann Arbor, MI 48108

Kentucky Location:

ENMET
62 Corporate Court
Bowling Green, KY 42103

Providing the “Service Request Form” assists in the expedient service and return of your unit and failure to provide this information can result in processing delays. **ENMET** charges a one hour minimum billing for all approved repairs with additional time billed to the closest tenth of an hour. All instruments sent to **ENMET** are subject to a minimum evaluation fee, even if returned unrepared. Unclaimed instruments that **ENMET** has received without appropriate paperwork or attempts to advise repair costs that have been unanswered after a period of 60 days may, be disposed of or returned unrepared COD and the customer will be expected to pay the evaluation fee. Serviced instruments are returned by UPS/FedEx Ground and are not insured unless otherwise specified. If expedited shipping methods or insurance is required, it must be stated in your paperwork.

NOTE: *Warranty of customer installed components.*

For Warranty Repairs, please reference **ENMET's** “Warranty Information and Guidelines” (found earlier in this section).

Mailing/Shipping Address:

ENMET
680 Fairfield Court
Ann Arbor, MI 48108
repair@enmet.com



Phone: 734.761.1270
Fax: 734.761.3220

Service Request Form

Product Name or Number:

Product Serial Number:

Describe Problem or Needed Service:

Warranty Claim? Yes No

CUSTOMER INFORMATION

Billing Address:

Shipping Address:

Contact Name: _____

Phone #: _____

Email: _____

Fax #: _____

PO/Reference #: _____

PAYMENT METHOD

COD VISA/MasterCard American Express

Card Number

Exp. Date

Security Code:

Name as it Appears on

Card: _____

RETURN SHIPPING METHOD

UPS Ground UPS 3 Day Select UPS Next Day Air UPS ND Air Saver UPS 2 Day Air

UPS Account #: _____

FedEx Ground FedEx Air Express Saver FedEx Air Overnight Std. FedEx Air 2 Day FedEx Air Overnight P-1

FedEx Account #: _____

Insure Shipment: Yes No

Insurance \$
Amount: _____