

**ENMET**

680 Fairfield Court  
Ann Arbor, MI 48108  
734.761.1270 Fax 734.761.3220

[www.enmet.com](http://www.enmet.com)

**ENMET**  
Creative Gas Detection Solutions



**GS-24-V  
Venturi Module  
With Enclosure and Filter  
Operation and Maintenance Manual**

## Table of Contents

<b>1.0 INTRODUCTION</b> .....	<b>2</b>
1.1 Unpack .....	2
1.2 Check Order .....	2
1.3 Serial Numbers.....	2
<b>2.0 INSTALLATION</b> .....	<b>3</b>
2.1 Installation Sample Draw Module .....	3
2.2 Installation of MOS/Combustible Sample Draw Adapter.....	5
<b>3.0 CALIBRATION</b> .....	<b>7</b>
<b>4.0 TERMS AND CONDITIONS</b> .....	<b>8</b>
4.1 Ordering Information .....	8
4.2 Shipping Terms .....	8
4.3 Payment .....	8
4.4 Warranty Information and Guidelines .....	8
4.5 Return Policy .....	9
4.6 Returning an Instrument for Service Instructions .....	9

## List of Figures

Figure 1: Mounting Dimensions .....	3
Figure 2: MOS Sensor Assembly.....	5
Figure 3: Combustible Sensor Assembly.....	6
Figure 4: Connect Gas to Venturi Module.....	7

### Reference Information:

**NOTE:** *[important information about use of instrument]*

**CAUTION:** *[affects equipment – if not followed may cause damage to instrument, sensor etc....]*

**WARNING:** *[affects personnel safety – if not followed may cause bodily injury or death.]*



Attention / Warning



Earth Ground

## 1.0 Introduction

The **ENMET Venturi Module** is designed to be used with most ENMET stationary sensor transmitters.

**NOTE:** *All specifications stated in this manual may change without notice.*

### 1.1 Unpack

Unpack the **Venturi Module** and examine it for shipping damage. If such damage is observed, notify both **ENMET** customer service personnel and the commercial carrier involved immediately.

### Regarding Damaged Shipments

**NOTE:** *It is your responsibility to follow these instructions. If they are not followed, the carrier will not honor any claims for damage.*

- This shipment was carefully inspected, verified and properly packaged at **ENMET** and delivered to the carrier in good condition.
- When it was picked up by the carrier at **ENMET**, it legally became your company's property.
- If your shipment arrives damaged:
  - Keep the items, packing material, and carton "As Is." Within 5 days of receipt, notify the carrier's local office and request immediate inspection of the carton and the contents.
  - After the inspection and after you have received written acknowledgment of the damage from the carrier, contact **ENMET** Customer Service for return authorization and further instructions. Please have your Purchase Order and Sales Order numbers available.
- **ENMET** either repairs or replaces damaged equipment and invoices the carrier to the extent of the liability coverage, usually \$100.00. Repair or replacement charges above that value are your company's responsibility.
- The shipping company may offer optional insurance coverage. **ENMET** only insures shipments with the shipping company when asked to do so in writing by our customer. If you need your shipments insured, please forward a written request to **ENMET** Customer Service.

### Regarding Shortages

If there are any shortages or questions regarding this shipment, please notify **ENMET** Customer Service within 5 days of receipt at the following address:

**ENMET**  
680 Fairfield Court  
Ann Arbor, MI 48108  
734-761-1270 Fax 734-761-3220  
Toll Free: 800-521-2978

### 1.2 Check Order

Check the contents of the shipment against the purchase order. Verify that the **Venturi Module** is received as ordered. If there are accessories on the order, ascertain that they are present. Check the contents of calibration kits. Notify **ENMET** customer service personnel of any discrepancy immediately.

### 1.3 Serial Numbers

Each **Venturi Module** is serialized. These numbers are on tags on the equipment and are on record in an **ENMET** database.

## 2.0 Installation

See **Figure 1** for mounting Dimensions. Dimensions are in inches.

### 2.1 Installation Sample Draw Module

1. Mount the sample draw module at a convenient location; use the four mounting holes provided. See **Figure 1**.

**CAUTION:** Do not exceed 120 PSI to inlet to the venturi pump.

2. Supply compressed air to the inlet of the venturi pump, located at the upper left side. The inlet fitting is a Hansen 1000 quick release pneumatic connector. If a different connector is desired, remove and discard the Hansen fitting; the replacement fitting must have ¼ NPT male threads.
3. The sensor assembly can be mounted on the sample draw assembly plate, or it can be located within six feet of the plate. If necessary, connect the sample line from the bottom port of the flowmeter to the output side of the sensor assembly.

**CAUTION:** If reactive gasses such as  $CL_2$ ,  $HCL$ ,  $NH_3$  or others are being sampled, make sure to use appropriate sample tubing material. Teflon lined vinyl tubing is acceptable for most applications.

4. Supply tubing from the sensor input fitting to the sample point. The sample must never include liquid.
5. Set the regulator between 8 and 18 PSI.
6. Set the flowmeter between 3.0 and 8.0 cc/min x 100.

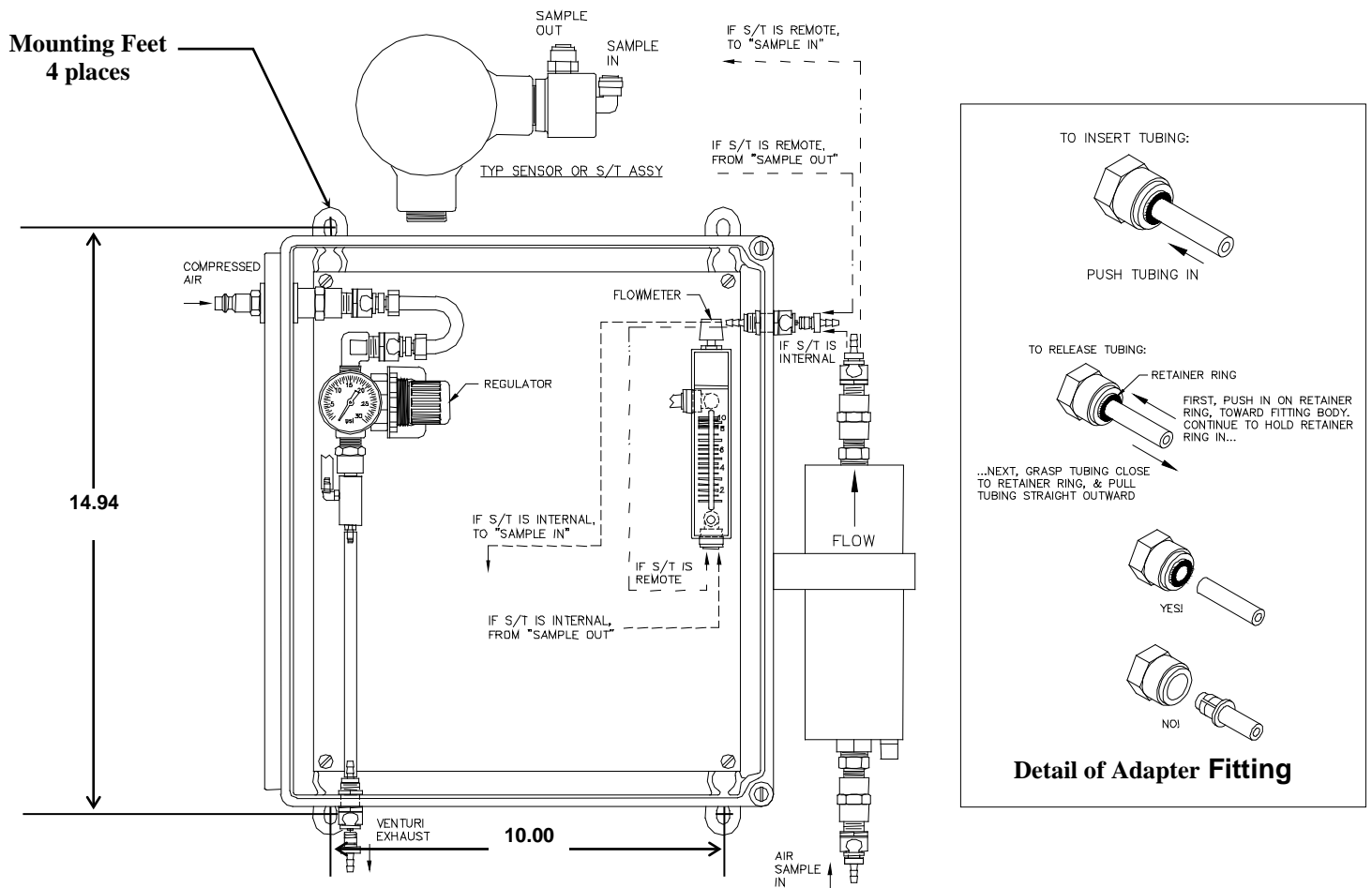

**Figure 1: Mounting Dimensions**

Internal view of the **ENMET Venturi Module** with pressure regulator

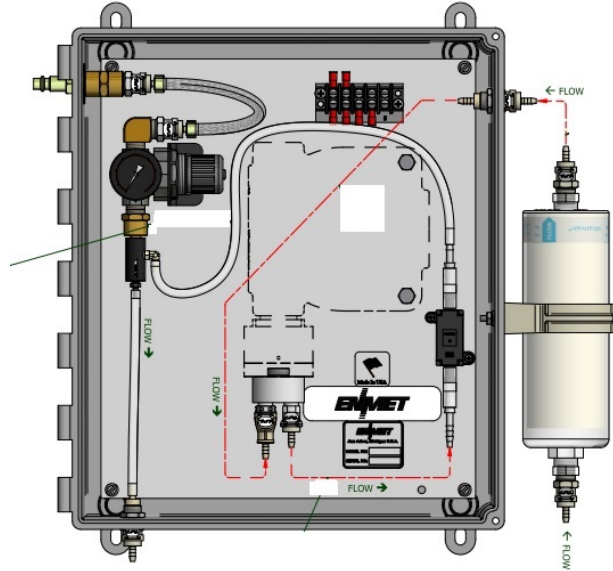

**Procedure to set the flow rate on the 04565-065 flow sensor**

Monitor the DC voltage across TB3 and TB4, adjust the pressure regulator to verify the voltage reading changes with the air pressure variance. Factory setting is 0.5 L

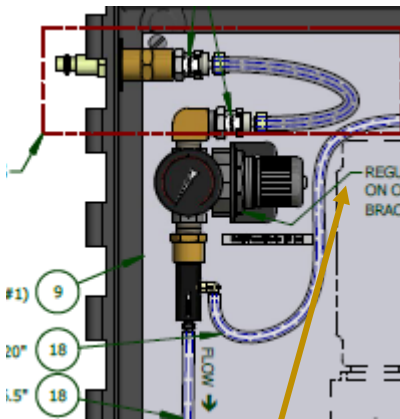

**Pressure regulator adjust**

Approximant Values	
Flow Rate	Output of Flow sensor
0LPM	1.010Vdc
0.1LPM	1.620Vdc
0.2LPM	2.150Vdc
0.3LPM	2.610Vdc
0.4LPM	3.034Vdc
0.5LPM	3.424Vdc
0.6LPM	3.750Vdc
0.7LPM	4.080Vdc
0.8LPM	4.370Vdc
0.9LPM	4.620Vdc
1LPM	4.910Vdc

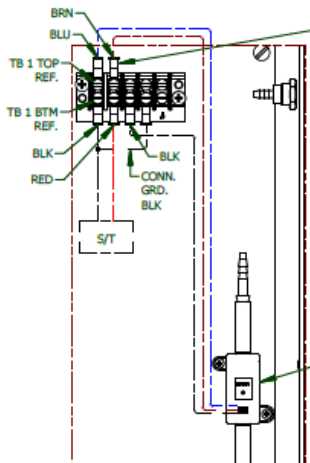

(TB3 TOP = signal output) (TB4 TOP = Ground)

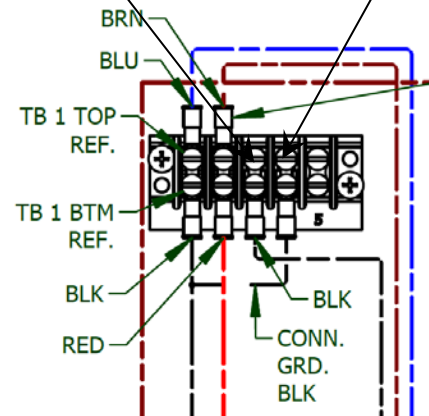

## 2.2 Installation of MOS/Combustible Sample Draw Adapter

**Proper operation and gas detection require that there be no leaks in the system.**

To insure proper operation a seal must be formed between the MOS sensor or Combustible sensor and the sample draw adapter. This is accomplished with the use of Teflon Tape.

Steps to Teflon Tape sensor and adapter:

1. Wrap the threads of the MOS sensor with Teflon tape, 4 to 6 complete rotations. Be sure to pull the tape tight as you wrap it, to insure the tape fills the threads.
2. FOR MOS SENSORS:
  - Remove the black retaining ring from the sensor and place 1 rotation of Teflon tape around the sensor to cover the TRU-Arc. See **figure 2 and 3** sensor assembly and sensor detail below. Note the direction of the black retaining ring.
  - Replace the black retaining ring and attach the sample draw adapter.
3. Tighten the sample draw adapter onto the sensor as far as possible.
4. Attach the input and output tubing to the adapter.
5. Check for leaks. With the sample draw system operating, plug the input connection to the sample draw adapter. Proper installation will register 0 flow rate on the flow meter. If the flow meter does not register 0, remove the sample draw adapter and re-tape it.
6. In order to remove the sample draw adapter, you must first disconnect the tubing from the adapter fitting. Press and hold the inner ring of the fitting while removing the tubing.

**CAUTION:** Do Not pull out the inner ring of adapter fitting. See detail of adapter fitting in **figure 1**.

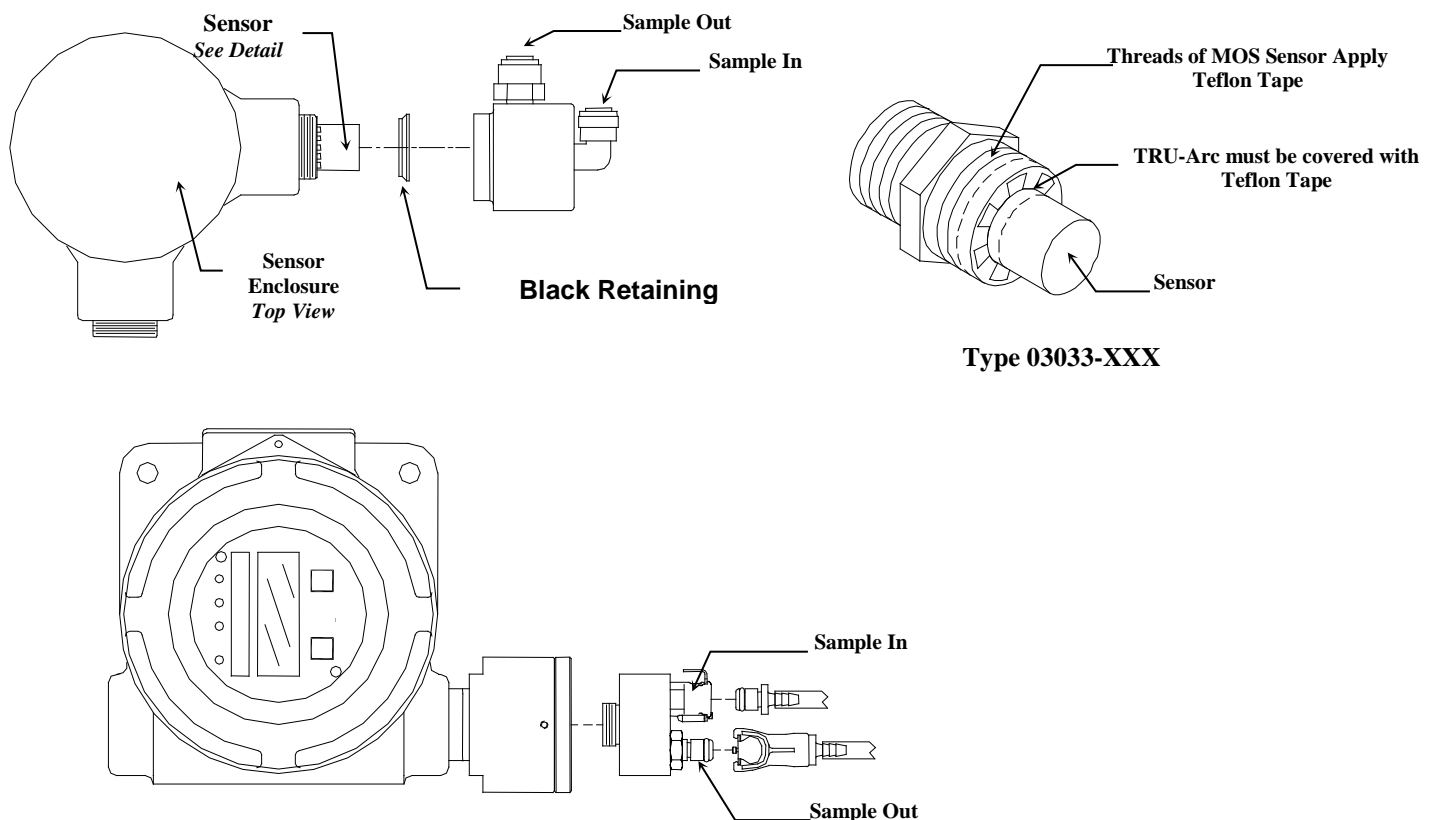

**Figure 2: MOS Sensor Assembly**

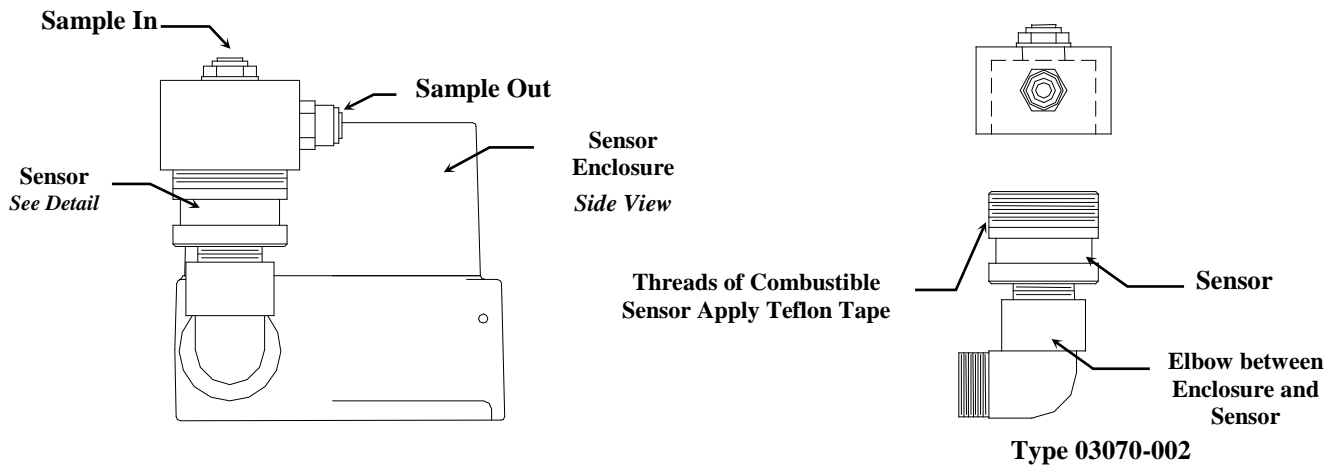
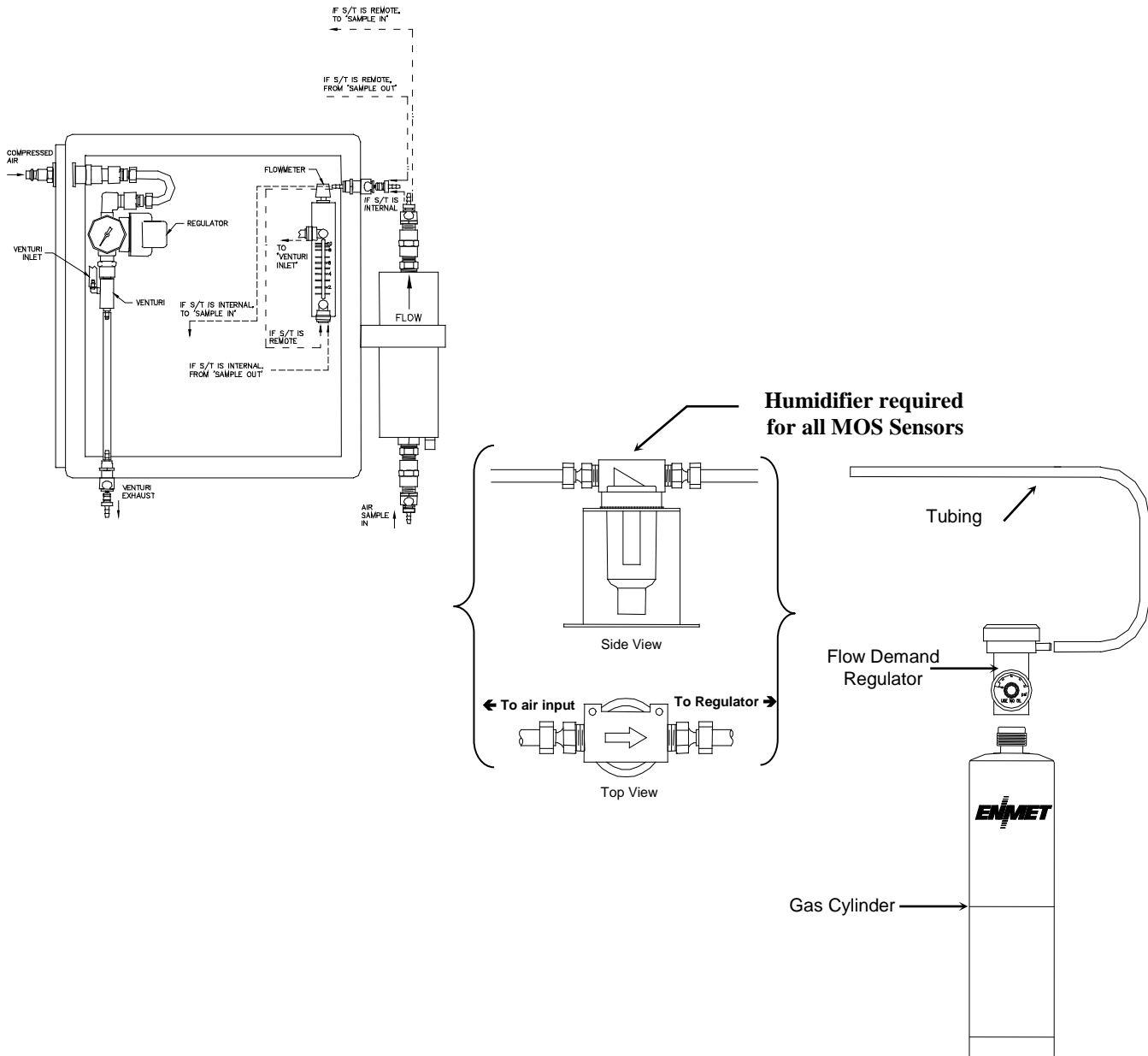

**Figure 3: Combustible Sensor Assembly**

### 3.0 Calibration

See **Figures 4 and 5.**

1. Consult monitor or sensor/transmitter manual to determine how to make adjustments to the circuitry during calibration.
2. Connect the appropriate calibration gas cylinder to the flow demand calibration adapter. For all MOS sensors supplying water to humidify gas is required. See **Figure 4.**
  - For Combustible Sensors: Connect the output of the flow demand regulator directly to the air input of the sample draw module.
  - For MOS Sensors: Connect the output of the flow demand regulator to the humidifier. Connect the output of the humidifier to the air input of the sample draw module.



**Figure 4: Connect Gas to Venturi Module**



## 4.0 Terms and Conditions

### 4.1 Ordering Information

Address orders to:

**ENMET**  
Attention: Customer Service Department  
680 Fairfield Court  
Ann Arbor, MI 48108

Email Orders: [orderentry@enmet.com](mailto:orderentry@enmet.com)

Phone: 734-761-1270

Fax: 734-761-3220

You may also contact our customer service department by email [info@enmet.com](mailto:info@enmet.com). MINIMUM ORDER IS \$50.00.

### 4.2 Shipping Terms

All shipments are F.O.B. ENMET's facility in Ann Arbor, MI, USA or Bowling Green, KY, USA. Shipping and handling charges are prepaid and added, and must be paid by the customer. Shipping and handling charges may be billed to VISA, MasterCard, American Express, or to the customer's preferred carrier account number. Delivery to the carrier constitutes delivery to the customer, and risk of loss passes to the customer at that time, however, title shall remain with ENMET until payment is received in full. Claims for shortages and damage must be made by the customer to the carrier within 5 days of receipt. **Refer to section "1.1 Unpack" for more information on this matter.**

A special service of \$50.00, or more, may be assessed on expedited shipments.

**NOTE:** Calibration gases are classified as Dangerous Goods for transportation purposes, and shipping companies charge a hazardous material fee for processing the documentation required for handling such items. Also, other restrictions apply to shipment of Danger Goods by air. Check with **ENMET** for clarification and additional information.

### 4.3 Payment

Open accounts must be established in advance with ENMET's Accounting department.

Address Payments to:

**ENMET**  
680 Fairfield Court  
Ann Arbor, MI 48108

Phone: 734-761-1270

We accept payments by VISA, MasterCard, and American Express. Payment by credit card must be specified at time of order placement. Your credit card will be charged on the date of shipment.

**ENMET** invoices for products that are shipped on open account are due and payable 30 days from the date of shipment from the **ENMET** site. **ENMET** may institute collection services should any bona fide invoice remain unpaid with no payment schedule negotiated by the customer with the **ENMET** Accounting Department. Any cost incurred by **ENMET** for professional collection services or legal fees to collect on a customer invoice will be added to any future business conducted between **ENMET** and that customer.

### 4.4 Warranty Information and Guidelines

Equipment must be returned prepaid to the point of origin, and ENMET will prepay the return transportation charges. Transportation prepaid by ENMET will be by most economical means (e.g. FedEx Ground). If an expedient means of transportation is requested during the warranty period, the customer must pay the difference between the most economical means and the expedient mode. ENMET warrants new instruments to be free from defects in workmanship and material under normal use for a calibration and expendable parts such as filters, detector tubes, batteries, etc. In addition, some oxygen cells and other sensors are limited to a warranty period of six months from date of shipment. Refer to the instrument manual for specific warranty details. If the inspection by ENMET confirms that the product is defective, it will be repaired or replaced at no charge, within the stated limitations, and returned prepaid by FedEx Ground to any location in the United States. ENMET shall not be liable for any loss or damage caused by the improper use or installation of the product. The purchaser indemnifies and holds harmless the company with respect to any loss or damages that may arise through the use by the purchaser or others of this equipment. This warranty is expressly given in lieu of all other warranties, either expressed or implied, including that of merchantability, and all other obligations, or liabilities of ENMET which may arise in connection with this equipment. ENMET neither assumes nor authorizes any representatives or other persons to assume for it any obligation or liability other than that which is set forth herein.

If a component is purchased and installed in the field, and fails within the warranty term, it can be returned to ENMET and will be replaced, free of charge. If the entire instrument is returned to ENMET with the defective item installed, it will be replaced at no cost, but the instrument will be subject to labor charges at half of the standard rate.

**NOTE:** When returning an instrument to the ENMET for service:

- o Be sure to include all paperwork (the “Request for Service” form).
- o Include any specific instructions.
- o For warranty service, include the date of purchase.
- o If you require an Estimate, please contact ENMET.

The “Request for Service” form is on the final page of this manual. This form can be copied or used as needed. For service requests, outside of the warranty period, please refer to the “Returning an Instrument for Service Instruction” found later in this section.

#### 4.5 Return Policy

**All returns for credit must be approved by ENMET and identified with a “Return Material Goods” number.** Such returns are subject to a minimum of a \$50.00 or 20% restocking fee, whichever is greater. **Approval of equipment for return is fully at the discretion of ENMET.** All requests for return/exchange must be made no later than 30 days of the original shipping date from *ENMET*. The actual amount of any resulting credit will not be determined prior to a complete inspection of the equipment by *ENMET*. Calibration gas cylinders cannot be returned or restocked due to the Department of Transportation refill restrictions. Air Filtration Systems (AFS series & parts) cannot be returned or restocked because their internal surfaces and filters are not amenable to re-inspection.

**Certain products, such as stationary systems, or instruments with custom sensor configuration (non-standard) are built to order, and cannot be returned.** Cancellation of orders for custom-built products, prior to shipment, will result in the assessment of a cancellation fee. The amount of the cancellation fee will be based upon the size and complexity of the order, and the percentage of total cost expended prior to cancellation.

#### 4.6 Returning an Instrument for Service Instructions

Contact the ENMET Service Department for all service requests.

Phone: 734-761-1270

Email: repair@enmet.com

Fill out the “Service Request Form” found at the end of this manual and return with your instrument for all needs. Please send your instrument for service to the site in which the product was purchased. A new “Service Request Form” may be requested if the one found in the manual is not available. All instruments should be shipped prepaid to ENMET.

Address for Service:

Michigan Location:

**ENMET**  
Attention: Service Department  
680 Fairfield Court  
Ann Arbor, MI 48108

Kentucky Location:

**ENMET**  
62 Corporate Court  
Bowling Green, KY 42103

Providing the “Service Request Form” assists in the expedient service and return of your unit and failure to provide this information can result in processing delays. *ENMET* charges a one hour minimum billing for all approved repairs with additional time billed to the closest tenth of an hour. All instruments sent to *ENMET* are subject to a minimum evaluation fee, even if returned unrepared. Unclaimed instruments that *ENMET* has received without appropriate paperwork or attempts to advise repair costs that have been unanswered after a period of 60 days may, be disposed of or returned unrepared COD and the customer will be expected to pay the evaluation fee. Serviced instruments are returned by UPS/FedEx Ground and are not insured unless otherwise specified. If expedited shipping methods or insurance is required, it must be stated in your paperwork.

**NOTE:** Warranty of customer installed components.

For Warranty Repairs, please reference *ENMET*’s “Warranty Information and Guidelines” (found earlier in this section).

**Mailing/Shipping Address:**

ENMET  
680 Fairfield Court  
Ann Arbor, MI 48108  
[repair@enmet.com](mailto:repair@enmet.com)



**Phone: 734.761.1270**  
**Fax: 734.761.3220**

**Service Request Form**

**Product Name or Number:**

**Product Serial Number:**

**Describe Problem or Needed Service:**

**Warranty Claim?**  Yes  No

**CUSTOMER INFORMATION**

**Billing Address:**

**Shipping Address:**

\_\_\_\_\_  
\_\_\_\_\_  
\_\_\_\_\_

\_\_\_\_\_  
\_\_\_\_\_  
\_\_\_\_\_

**Contact Name:** \_\_\_\_\_

**Phone #:** \_\_\_\_\_

**Email:** \_\_\_\_\_

**Fax #:** \_\_\_\_\_

**PO/Reference #:** \_\_\_\_\_

**PAYMENT METHOD**

- COD  VISA/MasterCard  American Express

Card Number

Exp. Date

Security Code:

**Name as it Appears on**

**Card:** \_\_\_\_\_

**RETURN SHIPPING METHOD**

- UPS Ground  UPS 3 Day Select  UPS Next Day Air  UPS ND Air Saver  UPS 2 Day Air

UPS Account #: \_\_\_\_\_

- FedEx Ground  FedEx Air Express Saver  FedEx Air Overnight Std.  FedEx Air 2 Day  FedEx Air Overnight P-1

FedEx Account #: \_\_\_\_\_

Insure Shipment:  Yes  No

Insurance \$  
Amount: \_\_\_\_\_