



CP-60

Operation and Maintenance Manual

Table of Contents

1.0 INTRODUCTION	3
1.1 IEC 60601-1 Classifications	3
1.2 Unpack	3
1.3 Check Order	3
1.4 Serial Numbers.....	3
2.0 INSTRUMENT FEATURES	4
2.1 CP-60 Exterior Features.....	4
2.2 Display CP-60 Front Panel Features	4
2.3 Circuit Board Features	5
3.0 INSTALLATION	6
3.1 Mounting of Instrument	6
3.3 Power Supply	6
3.4 Sensor/Transmitter Connection.....	7
3.4.1 Outputs.....	8
3.4.2 Relay Contacts	9
3.4.3 4-20mA Outputs.....	9
3.4.4 Digital Outputs	9
4.0 OPERATION	10
4.1 Normal Operation Condition	10
4.2 Alarm Conditions.....	10
4.3 Alarm Latching.....	10
4.4 Audio Defeat	10
4.5 Display	11
4.6 Operational Menu	11
4.7 Fault Indications.....	11
5.0 MAINTENANCE	12
5.1 Cleaning Instructions	12
5.2 Maintenance Menu CP-60	12
5.2.1 Set 4 –20mA Transmitter Scale	13
5.2.2 Set Alarm Points	14
5.2.3 Set Alarm “Delay On”	16
5.2.4 Relay Configuration.....	16
5.2.5 Failsafe Configuration.....	18
5.2.6 Set Output Span Range	18
5.2.7 Set New Password.....	19
5.2.8 Exit Maintenance Menu	19
5.3 Channel Activation/Deactivation	19
6.0 TECHNICAL DATA AND SPECIFICATIONS	20
7.0 REPLACEMENT PART NUMBERS	20
8.0 TERMS AND CONDITIONS	21
8.1 Ordering Information	21
8.2 Shipping Terms	21
8.3 Payment	21
8.4 Warranty Information and Guidelines	21
8.5 Return Policy	22
8.6 Returning an Instrument for Service Instructions	22

List of Figures

Figure 1:CP-60 External Features.....	4
Figure 2: CP-60 Interior Features	5
Figure 3: CP-60 Mounting Dimensions	6
Figure 4: CP-60 Relay, Input and Output Terminals	8
Figure 5: CP-60 Operational Display.....	10
Figure 6: CP-60 Operation Menu Flow Chart.....	11
Figure 7: CP-60 Maintenance Menu Flow Chart.....	12

List of Tables

Table 1: Relay Factory Default Failsafe Settings.....	9
Table 2: Default Relay Links	17

Reference Information:

NOTE: *[important information about use of instrument]*

CAUTION: *[affects equipment – if not followed may cause damage to instrument, sensor etc...]*

WARNING: *[affects personnel safety – if not followed may cause bodily injury or death.]*



Attention / Warning



Earth Ground

1.0 Introduction

The **CP-60** control panel is capable of monitoring from 1 to 3 remote sensors. Some features of the monitoring system are as follows:

- continuous LCD
- menu driven operational, maintenance controls, and calibration procedure
- audio and visual alarms indicate unsafe conditions. Alarm acknowledgement capability including audio defeat.
- alarm relay contacts available on terminals
- a fault relay and visual fault alarm
- mA output for each channel

NOTE: *All specifications stated in this manual may change without notice.*

1.1 IEC 60601-1 Classifications

- Type of protection against electrical shock: Class 1
- Degree of protection against electrical shock: No Applied Parts
- Main power quality should be that of a typical commercial environment

1.2 Unpack

Unpack the **CP-60** and examine it for shipping damage. If such damage is observed, notify both **ENMET** customer service personnel and the commercial carrier involved immediately.

Regarding Damaged Shipments

NOTE: *It is your responsibility to follow these instructions. If they are not followed, the carrier will not honor any claims for damage.*

- This shipment was carefully inspected, verified and properly packaged at **ENMET** and delivered to the carrier in good condition.
- When it was picked up by the carrier at **ENMET**, it legally became your company's property.
- If your shipment arrives damaged:
 - Keep the items, packing material, and carton "As Is." Within 5 days of receipt, notify the carrier's local office and request immediate inspection of the carton and the contents.
 - After the inspection and after you have received written acknowledgment of the damage from the carrier, contact **ENMET** Customer Service for return authorization and further instructions. Please have your Purchase Order and Sales Order numbers available.
- **ENMET** either repairs or replaces damaged equipment and invoices the carrier to the extent of the liability coverage, usually \$100.00. Repair or replacement charges above that value are your company's responsibility.
- The shipping company may offer optional insurance coverage. **ENMET** only insures shipments with the shipping company when asked to do so in writing by our customer. If you need your shipments insured, please forward a written request to **ENMET** Customer Service.

Regarding Shortages

If there are any shortages or questions regarding this shipment, please notify **ENMET** Customer Service within 5 days of receipt at the following address:

ENMET
680 Fairfield Court
Ann Arbor, MI 48108
734-761-1270 Fax 734-761-3220
Toll Free: 800-521-2978

1.3 Check Order

Check the contents of the shipment against the purchase order. Verify that the **CP-60** is received as ordered. If there are accessories on the order, ascertain that they are present. Check the contents of calibration kits. Notify **ENMET** customer service personnel of any discrepancy immediately.

1.4 Serial Numbers

Each **CP-60** is serialized. These numbers are on tags on the equipment and are on record in an **ENMET** database.

2.0 Instrument Features



2.1 CP-60 Exterior Features

The exterior of the instrument is shown in **Figure 1**. The exterior features are as follows:

Feature	Description
Enclosure	Engineered thermoplastic, approximately 11x9x6, with a clear hinged front cover.
Strain Relief	Entrance for Power and wiring to Remote Sensor
Audio Alarm	A loud horn activated by certain alarm conditions.
Mounting Flanges	Flanges with holes for mounting the enclosure to a vertical surface.

2.2 Display CP-60 Front Panel Features

The display panel, shown in **Figure 1**, is viewed through the clear front cover of the enclosure, and is accessed by opening the cover. Features are as follows:

Feature	Description
Display	2 line, 16 character per line, LCD with backlight. The numerical values of gas concentrations, and other information are displayed.
Visual Alarms & Indicators	On either sides of the display: A red alarm LED for each sensor transmitter installed to the instrument, Alarm 1. The top center: A red alarm LED for all sensor transmitters, Alarm 2. Near the center of the panel: A green power indicator LED A red fault alarm LED
Pushbutton Switches	There are three of these, located near the center of the panel; they are yellow rectangular membrane switches. They are:
<ul style="list-style-type: none"> OPTION Switch 	The top left switch. 
<ul style="list-style-type: none"> SELECT Switch 	Directly to the right of the OPTION switch. 
<ul style="list-style-type: none"> AUDIO DEFEAT / ALARM ACKNOWLEDGE Switch 	Directly below the OPTION switch. 

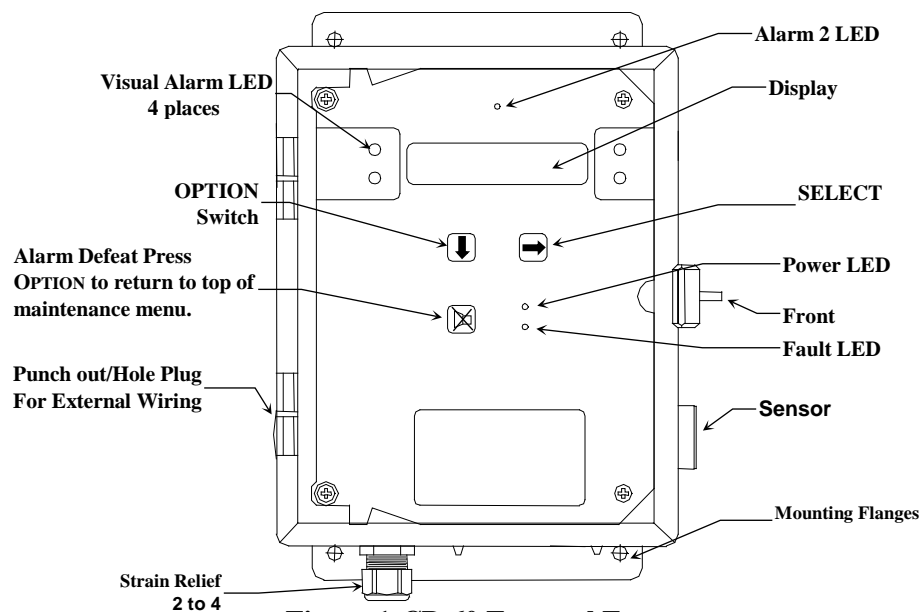

Figure 1:CP-60 External Features

2.3 Circuit Board Features

The Display Panel is hinged on the left and is released by unscrewing the 2 Philips screws located in the top and bottom right corners. After releasing the panel, it is swung to the left, exposing the interior of the enclosure. The Circuit Board is mounted on a plate at the back surface of the enclosure interior. Features are shown in **Figure 2**.

Feature	Description
Relay Terminals	This group of terminals is located at the left side of the Circuit Board. For the contacts for each of four alarm relays, and for the contacts of a fault relay.
Output Terminals	There are two for each of the 4-20 mA outputs.

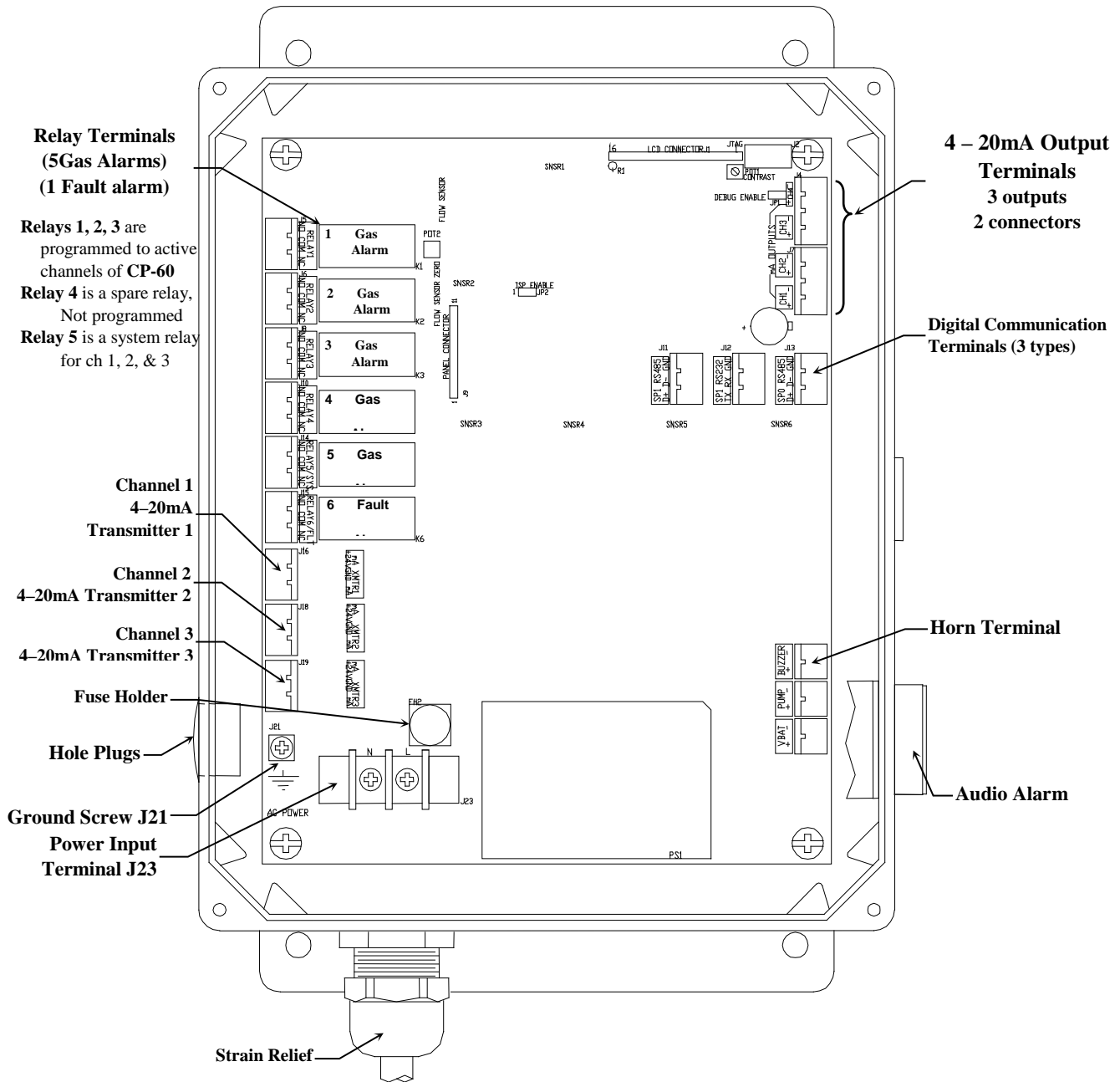

Figure 2: CP-60 Interior Features

3.0 Installation

3.1 Mounting of Instrument

Mount the **CP-60** instrument on an appropriate vertical surface using the mounting flanges provided. Avoid areas with excessive vibration or temperature extremes. The holes in the flanges are 0.31 inch in diameter and form a 6 x 10.75 inch rectangle. See **Figure 3**.

It is recommended to use #8 drywall anchors and screws for mounting the **CP-60** to a drywall/sheetrock surface.

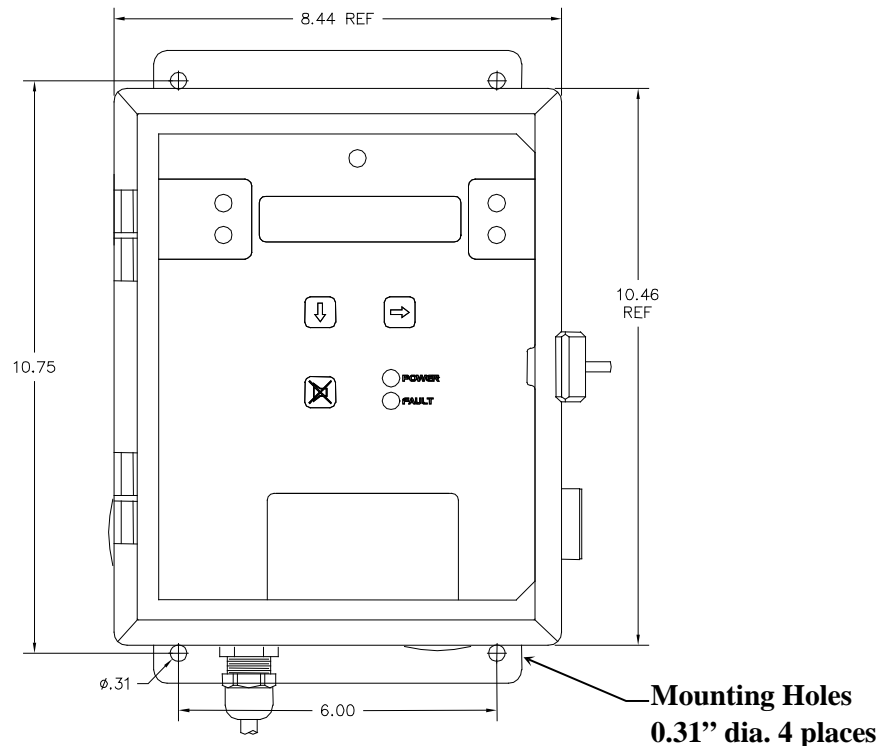

Dimensions are in inches.

Figure 3: CP-60 Mounting Dimensions

3.3 Power Supply

The electrical installation should conform to appropriate electrical codes, such as the National Electrical Code in the United States.

WARNING: The compliance of the installation to appropriate codes is not ENMET's responsibility.

The **CP-60** should be powered through appropriately sized circuit breakers. See **Section 6.0** Technical Data.

Upon supplying power to the **CP-60**:

- The green power on LED is lit.
- The display backlight is lit, and instrument will step through a start-up sequence: unit serial number, software revision and gases monitored may be shown on the display.

The instrument may go into alarm briefly, but should stabilize quickly. If the instrument persists in alarm, acknowledge the alarm by pressing the **AUDIO DEFEAT /ALARM ACKNOWLEDGE** switch. If alarm persists longer than 30 minutes, verify Sensor/Transmitter installation, call **ENMET** customer service personnel.

Mains power line is fused for power supply protection. Fuse is 5 x 20mm, 0.630Amp is located in FH2, see **Figure 5**



WARNING: Continuous gas detection and alarm systems become inoperative upon loss of primary power.

3.4 Sensor/Transmitter Connection

Sensor/Transmitters are connected to the **CP-60** control unit with two or three-conductor wiring, use the correct oil tight fitting. Size of wire depends on the distance between the sensor/transmitter and the control unit. See Recommended Wire Gauge Table below.

2 Wire for Sensors/Transmitter		3 Wire for Sensors/Transmitter	
Position	Function	Position	Function
1, V+	Power +24 VDC	1, V+	Power +24 VDC
2, G	Not Used	2, G	Power Ground
3, Sig	Signal/Return to Ground	3, Sig	Signal

Recommended Wire Gauge

Distance from Sensor to Control Unit	Recommended Wire Gauge
5000 feet	24 AWG
Greater than 5000 feet	Contact Factory

NOTE: Sensor Location

Gases have different densities. Some are heavier than air and concentrate at the bottom of a space. Some are lighter than air and gather at the top. Consider the density of the gas you want the sensor to detect when you install the sensor. Some examples are given below.

Heavier than Air Gas	Sensor Location
Bottled LP (liquefied petroleum)	<p style="text-align: center;">Interior wall; 18-24" from floor.</p> <ul style="list-style-type: none"> • DO NOT locate directly above or beside gas appliances (ovens, heaters). • Avoid locating anywhere near a vent or window or near an outside doorway.
Propane	
Butane	
Gasoline	
Trichloroethylene	
Vaporized hydrocarbons	
Hydrogen sulfide	
Lighter than Air Gas	Sensor Location
Natural gas (methane)	Near ceiling.
Ammonia	<ul style="list-style-type: none"> • DO NOT locate directly above appliances where it is subject to direct exposure to heat or steam.
Hydrogen	
Same Density as Air Gas	Sensor Location
Carbon Monoxide	<p>4-6 feet above the (generally uniform) floor.</p> <ul style="list-style-type: none"> ▪ DO NOT locate in direct air currents of windows, doors, or vents.

If you have a question involving the location of a unit or sensor, please contact your distributor or **ENMET** personnel. A technician will analyze the question and recommend a location.

3.4.1 Outputs

Two types of alarm outputs are available, relay contacts and 4-20mA outputs.

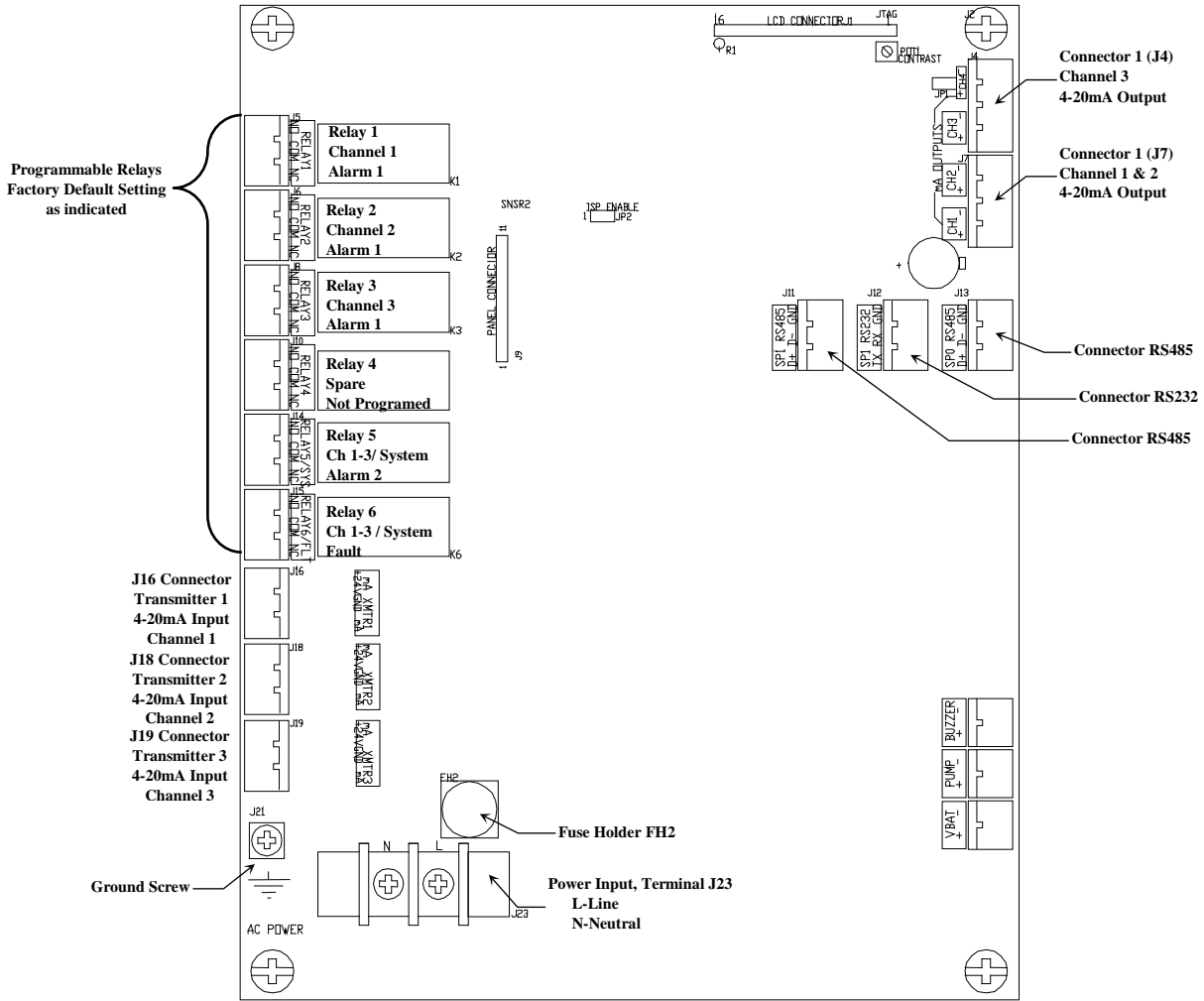

Figure 4: CP-60 Relay, Input and Output Terminals

3.4.2 Relay Contacts

Auxiliary alarms should be powered from an independent power source separate from the instrument power to avoid alarm failure due to controller malfunction.

Relay are SPDT, rated at 10Amp at 110VAC or 10Amp at 30VDC for restive loads, and may be latching or non-latching as required by the application. They are accessed on the terminals next to each relay see **Figures 2 & 5**. The contact positions are noted on the circuit board next to each terminal.

These relay coils are energized when they are in the non-alarm state; the contact conditions given above are for the non-energized state, which is identical to the alarm state.

In addition, there is a fault relay, which changes state whenever the instrument is in a fault condition. The contact positions are noted on the circuit board next to each terminal. The coil of this relay is energized when the instrument is in the non-fault state; the contact conditions given on the circuit board next to the terminal, are for the non-energized state, which is identical to the fault state.

The PC Board is labeled for the relays in their un-energized state. If the relay is configured for failsafe, then this is also the alarm condition state. Non-failsafe configured relays in the alarm state, are the reverse of the PC board labeling. Note that the Fault(FLT) relay cannot be set to operate in a Non-Failsafe mode. Please see the **Table 1** below:

Table 1: Relay Factory Default Failsafe Settings

Factory Default Settings	Position	Failsafe-Alarm	Non-Failsafe-Alarm
Gas Alarm 1 Channel 1	J5 Relay 1 - NO	Normally Open	Normally Closed
	J5 Relay 1 - COM	Common	Common
	J5 Relay 1 - NC	Normally Closed	Normally Open
Gas Alarm 1 Channel 2	J6 Relay 2 - NO	Normally Open	Normally Closed
	J6 Relay 2 - COM	Common	Common
	J6 Relay 2 - NC	Normally Closed	Normally Open
Gas Alarm 1 Channel 3	J8 Relay 3 - NO	Normally Open	Normally Closed
	J8 Relay 3 - COM	Common	Common
	J8 Relay 3 - NC	Normally Closed	Normally Open
Gas Alarm 1 Spare Not Programmed	J10 Relay 4 - NO	Normally Open	Normally Closed
	J10 Relay 4 - COM	Common	Common
	J10 Relay 4 - NC	Normally Closed	Normally Open
Gas Alarm 2 System Channel 1 – 3	J14 Relay 5 - NO	Normally Open	Normally Closed
	J14 Relay 5 - COM	Common	Common
	J14 Relay 5 - NC	Normally Closed	Normally Open
Fault	J15 Relay 6/FLT - NO	Normally Open	N/A
	J15 Relay 6/FLT - COM	Common	N/A
	J15 Relay 6/FLT - NC	Normally Closed	N/A

These relay contacts can be used to operate auxiliary alarms or other functions.

3.4.3 4-20mA Outputs

Isolated 4-20 mA outputs are available for data logging or other purposes. An output is supplied for each active channel. These outputs are available on the Connector 1(J7) for channels 1 & 2 and Connector 2(J4) for channels 3. 4mA corresponds to the sensor reading of 0 at the bottom of the range. 20mA corresponds to a full-scale reading.

Wiring requirements are the same as for the relays.

3.4.4 Digital Outputs

The RS232 & RS485 connections are used for firmware updates and digital communications. The **CP-60** is designed to operate as a Modbus slave. Contact the **ENMET** for further information on wiring for the digital outputs.

4.0 Operation

4.1 Normal Operation Condition

With the **CP-60** installed as described in **Section 3**, and in clean air, the **POWER** green LED is on, the display is lit, and the information on the display is as shown in **Figure 6**, for the sensor(s) installed in the **CP-60**. The red alarm and fault LEDs are not lit.

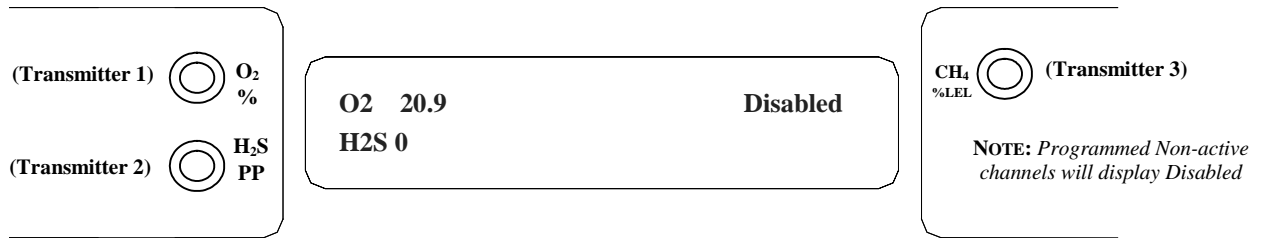

Example of display with Oxygen Channel 1, Hydrogen Sulfide Channel 2 and Methane Channel 3 **Disabled**.

Figure 5: CP-60 Operational Display

When the **CP-60** is first powered up, it goes through a series of momentary screens, which identify the instrument model number, serial number and software revision. After all the momentary screens have been displayed, the instrument arrives at the Main Gas Display showing the gas concentration and unit of measurement in ppm, % or % LEL Depending on transmitter configuration and calibration condition, the furthest right character in the display may flash a letter indicating the instrument status.

4.2 Alarm Conditions

There are two alarm set points available. These alarm points are normally set at established safety levels, such as the OSHA Permissible Exposure Limit (PEL) for toxic gases or recognized standards below the Lower Explosive Limit for combustible gases. The alarm set points can be changed within limits; see the maintenance section of this manual for the procedure. When the Oxygen, Toxic or combustible gas concentration reaches the alarm set point, the associated red LED is lit, the associated relay changes state, and the audio alarm is activated. Pressing the **ALARM ACKNOWLEDGEMENT/AUDIO DEFEAT** button can temporarily disable the Audio Alarm. The horn will be disabled for about five minutes. If a second alarm condition occurs during this time the horn will re-activate. If the alarm condition(s) have ended during this time, the horn will not re-activate.

Differential Setting

Differential is an optional alarm relay configuration where when an alarm has been triggered, the relay will remain in alarm state until the sensor reading has moved the differential “value” in the non-alarm direction. See example below.

- The Alarm 1 differential value is the delay of the **CP-60** staying in alarm condition until after the measured reading has returned past the alarm point by the differential value. *Example:* If the alarm point is **V** 19.5 and the differential is 2, the **CP-60** will go into alarm at 19.5 and stay in alarm until the reading has risen above 21.5.

4.3 Alarm Latching

An instrument is shipped with the alarms in the latching mode. The alarms may be independently configured in the non-latching mode or differential setting by use of the maintenance menu. See **Section 5.2.2**, for setting alarm 1 and alarm 2.

Standard Setting

- **IN THE LATCHING MODE:** at the cessation of the condition which causes an alarm, the alarm indications do not cease, and the alarm relay contacts do not revert to the non-alarm state, until the **ALARM ACKN/AUDIO DEFEAT** switch is pressed. An alarm can also be acknowledged by pressing the switch during the alarm condition; then at the cessation of the alarm condition, alarm indications cease and alarm relays revert to the non-alarm state. After an alarm is acknowledged, alarms in the latching configuration are re-armed to latch at the next alarm condition.
- **IN THE NON-LATCHING MODE:** at the cessation of the condition that causes an alarm, the alarm indications automatically cease, and the alarm relay contacts revert to the non-alarm state.

4.4 Audio Defeat

Pressing the **AUDIO DEFEAT / ALARM ACKNOWLEDGE** switch during an alarm temporarily silences the audio alarm on the **CP-60** not on the sensor/transmitter. Relays and alarm LEDs continue to function, in the alarm state, during an alarm condition. As long as the alarm condition persists, the audio alarm will “chirp” every 20 seconds. After the alarm condition clears, the audio will continue to “chirp” until the audio switch is pressed.

If after 15 minutes the alarm condition continues the audio alarm will reactivate at full intensity. If any other alarm condition occurs while the audio alarm has been silenced it will force the audio alarm to reactivate immediately.

4.5 Display

In clean air a display is shown in **Figure 4**. This position of the display is termed the "**operational display**". As explained below, the display can be changed to furnish other information by using the OPTION and SELECT switches.

4.6 Operational Menu

The operational menu allows the user to:

- View alarm set point concentration values
- View alarm latching configurations
- Enter the maintenance menu with the proper Password.

The operational menu is accessed with the OPTION and SELECT switches. The operational menu flow chart is in **Figure 7**,

- Pressing the OPTION switch is indicated with a "O"
- Pressing the SELECT switch is indicated with a "S".

If the instrument is left at any location in the operational or maintenance menus, other than the operational display, with no action taken for a period of 45 seconds, it returns to the operational display.

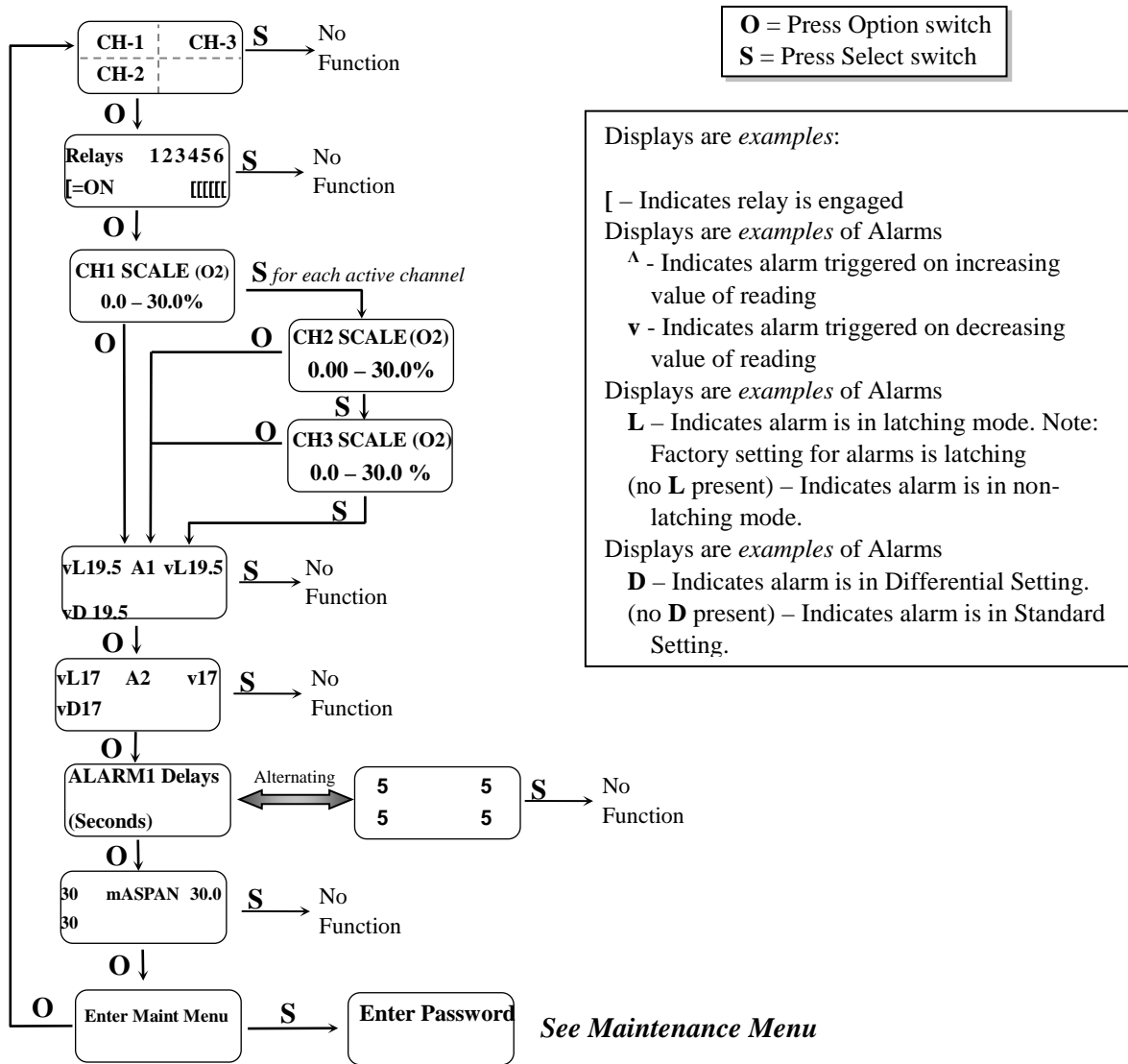

Figure 6: CP-60 Operation Menu Flow Chart

4.7 Fault Indications

Fault indication occurs:

- When a transmitter is not connected to an active channel of the CP-60.
- When a connected Sensor/Transmitter reading falls outside of its operation parameters (See sensor/transmitter manual).

5.0 Maintenance

The CP-60 has no specific preventative maintenance requirements. Entering the maintenance menu, as outlined in Section 5.2 may change instrument configurations.

5.1 Cleaning Instructions

CAUTION: Never spray a cleaning solution on the surfaces of the CP-60.

Clean the exterior of the CP-60 enclosure with a mild soap solution on a clean, damp cloth. Do not soak the cloth with solution so that moisture drips onto, or lingers on, external surfaces. Under no circumstances should organic solvents such as paint thinner be used to clean instrument surfaces.

5.2 Maintenance Menu CP-60

The maintenance menu diagram is shown in Figure 8 Maintenance Menu Flow Chart. From the operational display, press the OPTION switch until; "Enter MAINTENANCE Menu" is displayed.

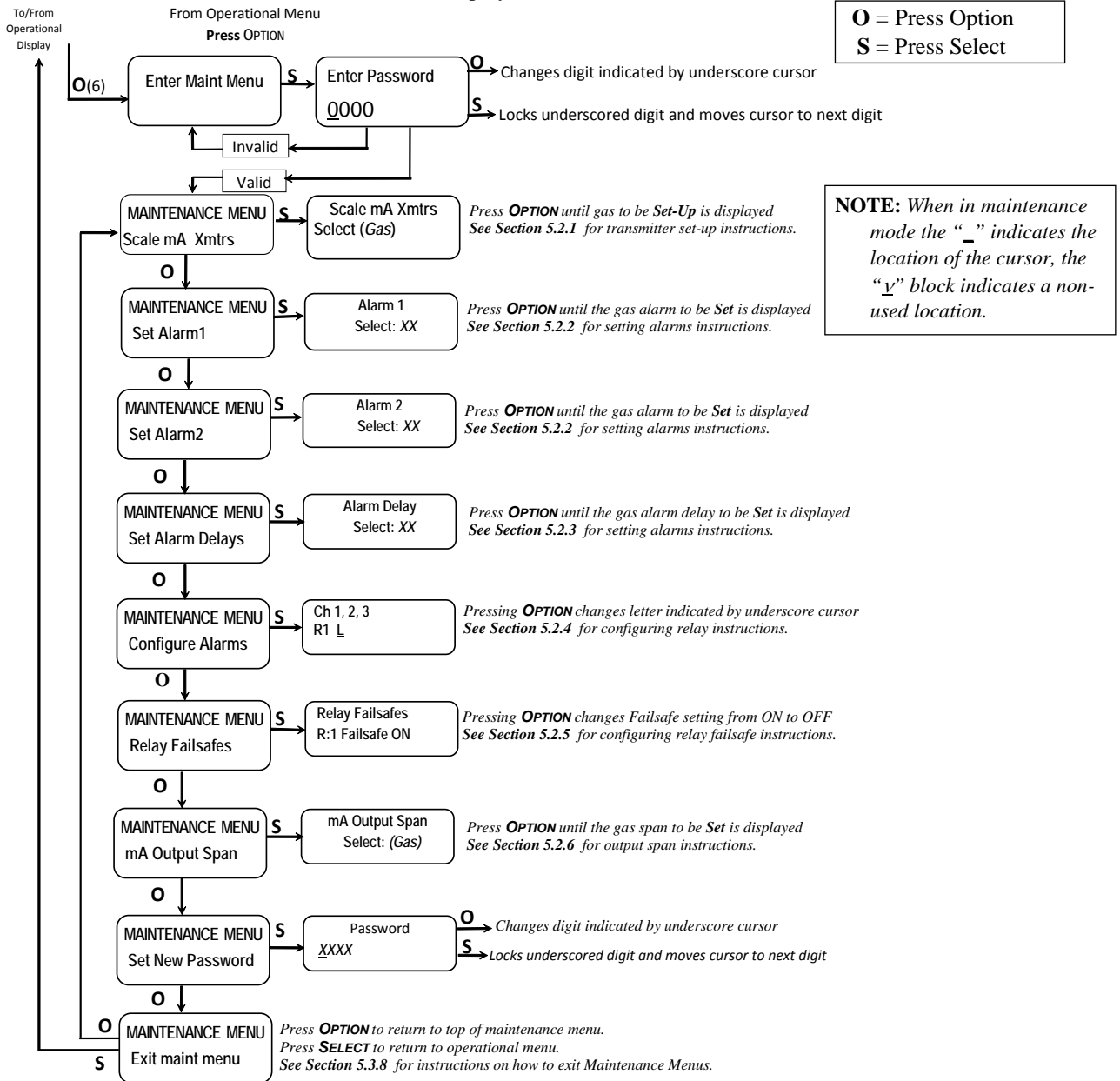

Figure 7: CP-60 Maintenance Menu Flow Chart

5.2.1 Set 4 –20mA Transmitter Scale

This section of the maintenance menu is for external sensor/transmitters. This function is normally performed at the factory and is not usually required in the field unless a new transmitter with a different range is installed.

After entering a valid password into maintenance menu, the Scale mA Xmtrs section is the second menu section, if it is installed, enter by pressing the SELECT switch

- Press the SELECT switch "mA Xmter Scale: Select XX" is displayed. XX = the gas to be set up.
- Press the OPTION switch, if needed, to change to the gas to be set up.
- Press the SELECT switch, "Ch#: mAXmter: 4mA: 0000" is displayed
- Press the SELECT switch, that moves the cursor one digit to the right when the last digit is accepted the display move to the full Scale mA Xmtrs menu
- Press the SELECT switch, "Ch#: mAXmter: 20mA: 0000" is displayed
- Press the SELECT switch, that moves the cursor one digit to the right when the last digit is accepted the display will return to the Scale mA Xmtrs menu
- Repeat these steps for each 4 –20mA transmitter.
- Press the OPTION switch, to continue on to the next section of the Maintenance Menu.

Example: Oxygen Sensor/Transmitter 0 – 30%

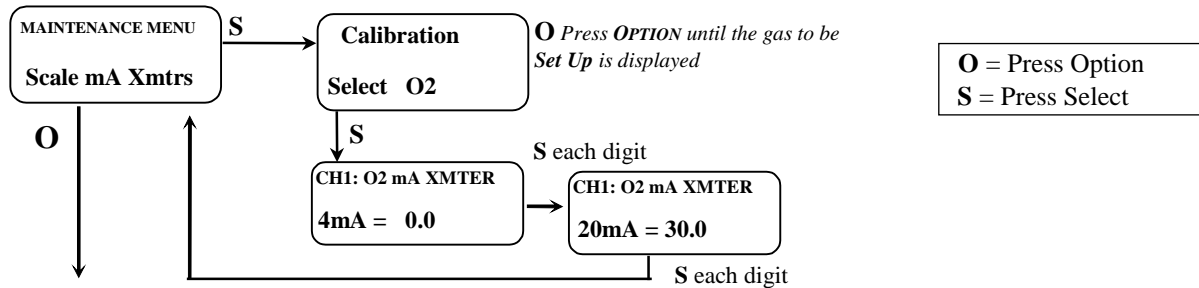

5.2.2 Set Alarm Points

Factory alarm set points are discussed in Section 4.2, See Table 1. To change the alarm points, you must enter the maintenance menu.

NOTE: *Changing the alarm points on the CP-60 will NOT change the alarm points on the sensor transmitter.*

Entrance to the maintenance menu is guarded with a four-digit Password. The factory default setting of the password is 1270. When a valid numerical password is inserted, the user is allowed to enter the maintenance menu.

In the "Enter Maint Menu" position

- Press the **SELECT** switch "Enter Password 0" is displayed. Press **SELECT** switch once, to move cursor to next digit, this will be the first digit of the password.
- In the 000 position, the underline cursor is under the left digit.
- Press the **OPTION** switch to change the left digit; select the correct digit.
- Press the **SELECT** switch, which locks the digit in place and moves the cursor one digit to the right.

Continue this process until the four-digit password is complete. When a valid password is inserted in this manner, the display is transferred to the "Calibration" portion of the menu. If an invalid password is inserted you are returned to the Enter Maint Menu display.

After entering a valid password:

- Press the **OPTION** switch until; "Maintenance Menu Set Alarm1" appears on display.
- Press the **SELECT** switch, "ALARM1 Select: O2" *example* is displayed.
- Press the **SELECT** switch; "ALARM 1 V" is displayed, with the indicator flashing, **Λ** for ascending trigger point or **V** for descending trigger point indicator.
- Press the **OPTION** switch to toggle between **Λ** and **V**; select the correct indicator.
- Press the **SELECT** switch to lock in the correct indicator. "ALARM 1 **STD**" is displayed
- Press the **OPTION** switch to toggle between **STD** and **DIFF**; select the correct indicator.
- Press the **SELECT** switch to lock in the correct indicator.

IF: **STD** is selected, "ALARM 1 V**L**" is displayed.

- The next character is the latching indicator **L** or **NO**L**** press the **OPTION** switch to toggle the latching mode.
- The next characters are the alarm 1 value, press the **OPTION** switch to select each digit of the value
When the last digit is accepted display returns to the Maintenance Menu "Set Alarm1" position.

IF: **DIFF** is selected, "ALARM 1 **V** **DIFF** 19.5" is displayed, Factory default setting.

- The next characters are the alarm 1 value, press the **OPTION** switch to select each digit of the value
- Move the cursor to the first digit and, Press the **SELECT** switch to lock in the correct character and move the cursor to the right.
- "ALARM 1 **DIFF BAND** 0.0" is displayed, to *set alarm 1 differential*. With **SELECT** switch move cursor to left.
- Press the **OPTION** switch to select each digit of the value.

NOTE: *The Alarm 1 differential value is the delay of the CP-60 staying in alarm condition until after the measured reading has returned past the alarm point by the differential value. Example: If the alarm set point is **V** 19.5 and the differential is 2, the CP-60 will go into alarm at 19.5 and stay in alarm until the reading has risen above 21.5.*

- Repeat the above procedure for each sensor alarm 1 to be changed.
- Press the **OPTION** switch to move to alarm 2, "Set ALARM2" is displayed.
- Repeat as for alarm 1 using the **STD** section. Alarm Diff is not available for Alarm 2.
- Press **OPTION** switch until "Exit Maint Menu" appears, then press **SELECT** switch to return the instrument to the Operational Display

NOTE: *When in maintenance mode the " " indicates the location of the cursor, the " " block indicates a non-used location.*

Example: Set Alarms Flow Chart

Displays shown are factory default settings.

Λ - Indicates alarm triggered on increasing value of reading

v - Indicates alarm triggered on decreasing value of reading

L- Indicates alarm is set for latching

NOL- Indicates alarm is set for non-latching

STD – Indicates alarm in standard setting, can be set in latched or non-latched mode

DIFF – Indicates alarm in differential setting, instrument will stay in alarm beyond the alarm set point by the differential value

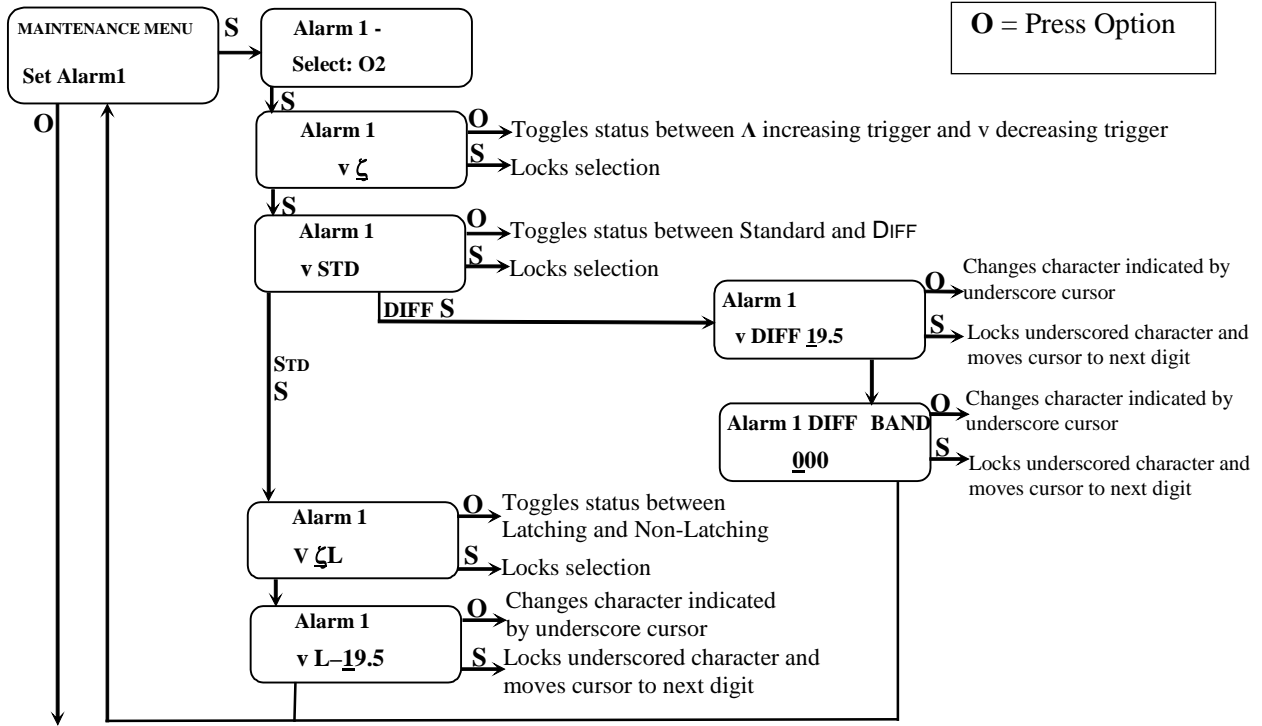

NOTE: When in maintenance mode the “_” indicates the location of the cursor, the “v” block indicates a non-used location.

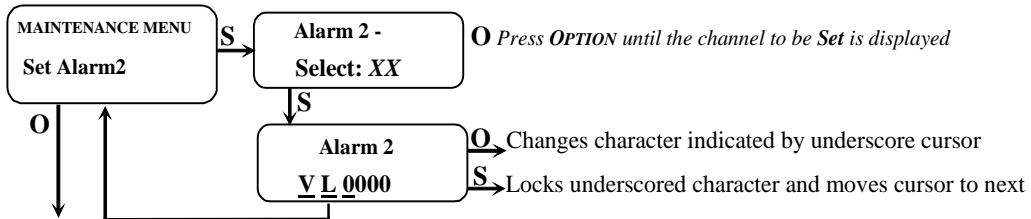

5.2.3 Set Alarm “Delay On”

The alarms may be set to delay activation by 1 second increments, from 1 to 30 seconds.



WARNING: Extended alarm delays may cause operational failures, injury or death.

Factory set default value is 5 seconds.

After entering a valid password:

- Press the **OPTION** switch until; “Maintenance Menu Set Alarm Delay” appears on display.
- Press the **SELECT** switch, "ALARM Delay Select: O2" is displayed.
- Press the **SELECT** switch; "ALARM Delay = 05" is displayed, with the underscore cursor under the left position.
- Press the **SELECT** switch to move the cursor and the **OPTION** switch to lock in the correct digit and move the cursor one digit to the right. Press the **SELECT** switch when the last digit is accepted display returns to the "Set Alarm Delay" position.
- Press the **OPTION** switch to continue to the Set New Password section

NOTE: When in maintenance mode the “ ” indicates the location of the cursor, the “v” block indicates a non-used location.

Example: Set Alarm Delay Flow Chart

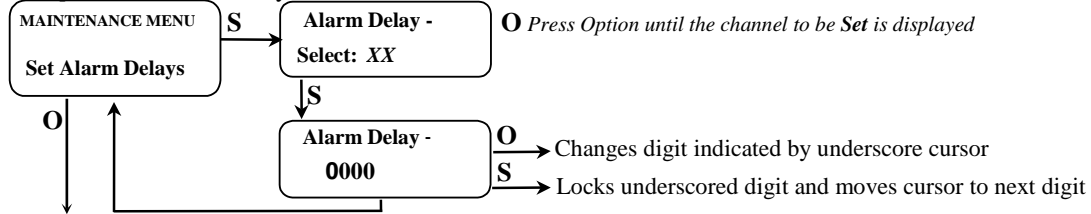

5.2.4 Relay Configuration

To change a relay configuration, you must enter the maintenance menu. Press the **OPTION** switch until “Enter Maint Menu” is displayed then press **SELECT** switch for the Enter Password menu. Enter the valid password as described below.

In the "Enter Maint Menu" position

- Press the **SELECT** switch "Enter Password 0" is displayed. Press **SELECT** switch once, to move cursor to next digit, this will be the first digit of the password.
- In the 000 position, the underline cursor is under the left digit.
- Press the **OPTION** switch to change the left digit; select the correct digit.
- Press the **SELECT** switch, which locks the digit in place and moves the cursor one digit to the right. Continue this process until the four-digit password is complete. When a valid password is inserted in this manner, the display is transferred to the "Calibration" portion of the menu. If an invalid password is inserted, you are returned to the Enter Maint Menu display.

After entering a valid password:

- Press the **OPTION** switch until “Configure Alarms” is displayed
L = Low Alarm = Alarm 1, **H** = High Alarm = Alarm 2, **B** = Both Alarms, = No Relay linked to channel

Example: Set Relay Configuration Flow Chart

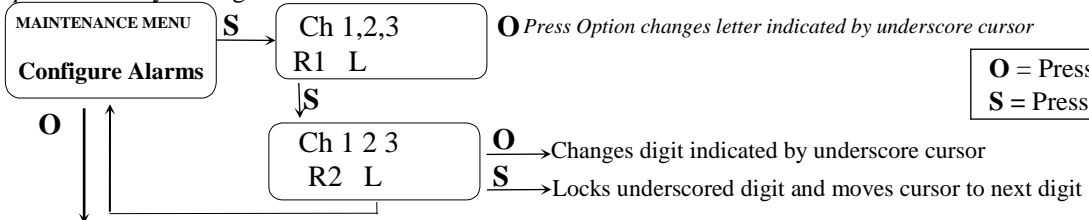

O = Press Option
S = Press Select

The **Table 2** below shows the default relay links for 3 channel system.

Table 2: Default Relay Links

	Channel 1	Channel 2	Channel 3	Channel 4
Relay 1	Low Alarm			Channel 4 Not Available in CP-60 Default programming of circuit only
Relay 2		Low Alarm		
Relay 3			Low Alarm	
Relay 4	Spare	Spare	Spare	
Relay 5	High Alarm	High Alarm	High Alarm	

Relays can be linked to specific alarms.

NOTE: *Each operating channel must be linked to at least 1 relay.*

5.2.5 Failsafe Configuration

The CP-60 is factory set in a failsafe configuration. This means that if power is disconnected to the unit, or the relay fails to properly engage, it fails in such a way that it is in the alarm position. ENMET recommends leaving the relay in a failsafe configuration. However, relay 1 – 5 can be re-configured by using the following procedure.

To change a relay failsafe configuration, you must enter the maintenance menu. Press the **OPTION** switch until “Enter Maint Menu” is displayed then press **SELECT** switch for the Enter Password menu. Enter the valid password as described below.

In the "Enter Maint Menu" position

- Press the **SELECT** switch "Enter Password 0" is displayed. Press **SELECT** switch once, to move cursor to next digit, this will be the first digit of the password.
 - In the 000 position, the underline cursor is under the left digit.
 - Press the **OPTION** switch to change the left digit; select the correct digit.
 - Press the **SELECT** switch, which locks the digit in place and moves the cursor one digit to the right.
- Continue this process until the four-digit password is complete. When a valid password is inserted in this manner, the display is transferred to the "Calibration" portion of the menu. If an invalid password is inserted you are returned to the Enter Maint Menu display.

After entering a valid password:

- Press the **OPTION** switch until “Relay Failsafes” is displayed

NOTE: When in maintenance mode the “_” indicates the location of the cursor, the “ ” block indicates a non-used location.

Example: Set Relay Failsafe Configuration Flow Chart

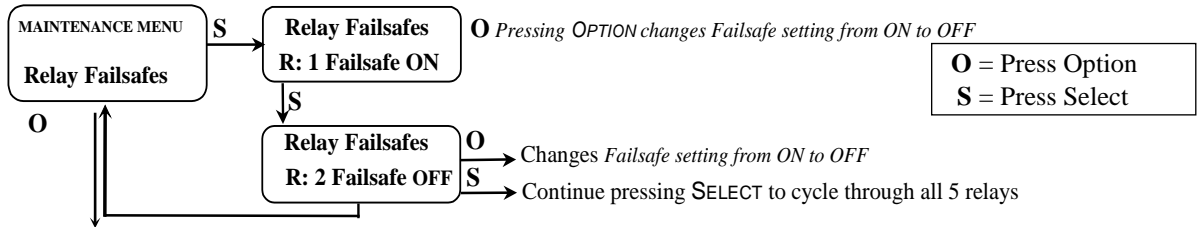

5.2.6 Set Output Span Range

To change 4-20 mA output range. This range is set at the factory and should not be changed, contact ENMET for information.

- Press the **OPTION** switch to continue to next section of maintenance menu.
- Press **OPTION** switch until “Exit Maint Menu” appears and then press **SELECT** switch to return the instrument to the Operational Display

Example: Set Output Span Flow Chart

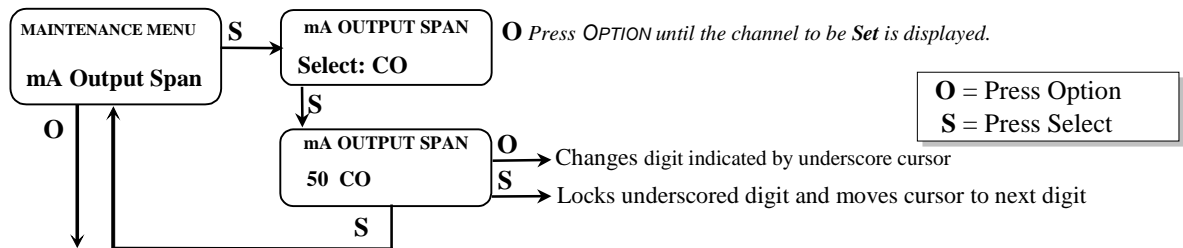

5.2.7 Set New Password

To change the password, you must enter the maintenance menu. Press the **OPTION** switch until “Enter Maint Menu” is displayed then press **SELECT** switch for the Enter Password menu. Enter the valid password as described in Section 5.2.1.

To set a new password, after inserting a valid password,

- Press the **OPTION** switch until; "Set New Password" is displayed.
- Press the **SELECT** switch; "Password █1270" is displayed, with the underscore cursor under the left digit.
- Use the **OPTION** switch to change the left digit, when the desired digit is displayed.
- Press the **SELECT** switch to lock the digit in place and move the cursor one digit to the right.

When all four digits of the new password have been selected, "Set New Password" is displayed.

Record the new password; without it, the maintenance menu cannot be reentered once you exit the Maintenance Menu. If the password is lost, call **ENMET** customer service personnel.

From the "Password XXXX" position,

- Press the **SELECT** switch to return to Set New Password section.
- Press the **OPTION** switch; to continue to "exit MAINTENANCE Menu"

Note: When in maintenance mode the “_” indicates the location of the cursor, the “v” block indicates a non-used location.

Example: Set Password Flow Chart

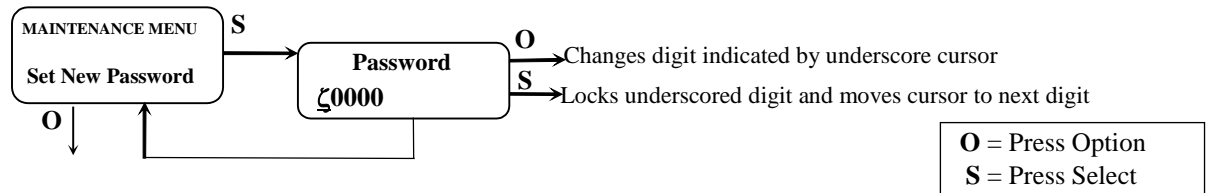

5.2.8 Exit Maintenance Menu

From the "exit MAINTENANCE Menu" position

Press the **SELECT** switch to resume the operational display.

Press the **OPTION** switch to reenter the maintenance menu at the "Calibration" position.

Example: Exit Maintenance Menu Flow Chart

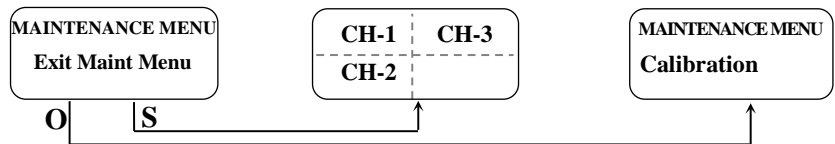

5.3 Channel Activation/Deactivation

Each channel of the **CP-60** can be deactivated and activated as needed.

CAUTION: Deactivated channels will not display or respond to connected sensor transmitters.

A fault indication occurs when a transmitter is not connected to an active channel of the **CP-60**.

To Activate or deactivate a channel of the **CP-60:**

- Enter the maintenance menu as described in **Section 5.2** and press the **OPTION** switch until Exit Maint Menu appears.
- Press and **Hold** the **OPTION** switch until “ADV Maint Menu” is displayed.
- Press the **SELECT** switch to locate the channel to be changed.
- Press the **OPTION** switch to change the status of that channel.
- Press the **SELECT** switch to accept the change in status. “ADV Maint Menu Exit” is displayed.
- Press the **SELECT** switch to return to the operational menu.

6.0 Technical Data and Specifications

The technical data and specifications of the **CP-60** instrument.

Electrical Power	15 Amp fused branch circuit	
	100 – 240 VAC	
	0.9 A	
	50/60 Hz	
	Board Mounted Fuse FH2, 0.630A, 5 x 20mm	
Storage and Transport	Temperature:	-20°C to +60°C (-4°F to +140°F)
	<i>preferred</i>	0°C to +20°C (32°F to 68°F)
	Relative Humidity	0 – 100% RH, non-condensing
	Ambient Pressure	20 to 36 inHg (68 to 133 kPa)
Operation	Temperature:	0°C to +40°C (32°F to +104°F)
	Relative Humidity	0 – 100% RH, non-condensing
	Ambient Pressure	20 to 36 inHg (68 to 133 kPa)
Mechanical	Dimensions:	11 x 9 x 6 inches (28 x 23 x 16 cm)
	Weight:	8 lbs (3.6 kg)
	Material:	Engineered thermoplastic with hinged front cover Non-magnetic hardware
	Strain relief:	5 – 12 mm OD
Outputs	Relays:	SPDT Resistive Load Inductive Load 10A at 110 VAC 7.5A at 110 VAC 10A at 30 VDC 5A at 30 VDC
	Analog:	4-20 mA x 3
	Digital:	RS-232 – Modbus RS-485 – Modbus
	Audio:	90 db at 2 ft

NOTE: All specifications stated in this manual may change without notice.

7.0 Replacement Part Numbers

ENMET part numbers for replacement parts:

Part number	Description
64002-630	Fuse, 0.630 Amp 5x20mm
65057-011	Terminal plug, 3 position
65057-012	Terminal plug, 4 position
65057-010	Terminal plug, 2 position

Notes:

8.0 Terms and Conditions

8.1 Ordering Information

Address orders to:

ENMET
Attention: Customer Service Department
680 Fairfield Court
Ann Arbor, MI 48108

Email Orders: orderentry@enmet.com

Phone: 734-761-1270

Fax: 734-761-3220

You may also contact our customer service department by email info@enmet.com. MINIMUM ORDER IS \$50.00.

8.2 Shipping Terms

All shipments are F.O.B. ENMET's facility in Ann Arbor, MI, USA or Bowling Green, KY, USA. Shipping and handling charges are prepaid and added, and must be paid by the customer. Shipping and handling charges may be billed to VISA, MasterCard, American Express, or to the customer's preferred carrier account number. Delivery to the carrier constitutes delivery to the customer, and risk of loss passes to the customer at that time, however, title shall remain with ENMET until payment is received in full. Claims for shortages and damage must be made by the customer to the carrier within 5 days of receipt. **Refer to section "1.1 Unpack" for more information on this matter.**

A special service of \$50.00, or more, may be assessed on expedited shipments.

NOTE: Calibration gases are classified as Dangerous Goods for transportation purposes, and shipping companies charge a hazardous material fee for processing the documentation required for handling such items. Also, other restrictions apply to shipment of Danger Goods by air. Check with **ENMET** for clarification and additional information.

8.3 Payment

Open accounts must be established in advance with ENMET's Accounting department.

Address Payments to:

ENMET
680 Fairfield Court
Ann Arbor, MI 48108

Phone: 734-761-1270

We accept payments by VISA, MasterCard, and American Express. Payment by credit card must be specified at time of order placement. Your credit card will be charged on the date of shipment.

ENMET invoices for products that are shipped on open account are due and payable 30 days from the date of shipment from the **ENMET** site. **ENMET** may institute collection services should any bona fide invoice remain unpaid with no payment schedule negotiated by the customer with the **ENMET** Accounting Department. Any cost incurred by **ENMET** for professional collection services or legal fees to collect on a customer invoice will be added to any future business conducted between **ENMET** and that customer.

8.4 Warranty Information and Guidelines

Equipment must be returned prepaid to the point of origin, and ENMET will prepay the return transportation charges. Transportation prepaid by ENMET will be by most economical means (e.g. FedEx Ground). If an expedient means of transportation is requested during the warranty period, the customer must pay the difference between the most economical means and the expedient mode. ENMET warrants new instruments to be free from defects in workmanship and material under normal use for a calibration and expendable parts such as filters, detector tubes, batteries, etc. In addition, some oxygen cells and other sensors are limited to a warranty period of six months from date of shipment. Refer to the instrument manual for specific warranty details. If the inspection by ENMET confirms that the product is defective, it will be repaired or replaced at no charge, within the stated limitations, and returned prepaid by FedEx Ground to any location in the United States. ENMET shall not be liable for any loss or damage caused by the improper use or installation of the product. The purchaser indemnifies and holds harmless the company with respect to any loss or damages that may arise through the use by the purchaser or others of this equipment. This warranty is expressly given in lieu of all other warranties, either expressed or implied, including that of merchantability, and all other obligations, or liabilities of ENMET which may arise in connection with this equipment. ENMET neither assumes nor authorizes any representatives or other persons to assume for it any obligation or liability other than that which is set forth herein.

If a component is purchased and installed in the field, and fails within the warranty term, it can be returned to ENMET and will be replaced, free of charge. If the entire instrument is returned to ENMET with the defective item installed, it will be replaced at no cost, but the instrument will be subject to labor charges at half of the standard rate.

NOTE: When returning an instrument to the ENMET for service:

- o Be sure to include all paperwork (the “Request for Service” form).
- o Include any specific instructions.
- o For warranty service, include the date of purchase.
- o If you require an Estimate, please contact ENMET.

The “Request for Service” form is on the final page of this manual. This form can be copied or used as needed. For service requests, outside of the warranty period, please refer to the “Returning an Instrument for Service Instruction” found later in this section.

8.5 Return Policy

All returns for credit must be approved by ENMET and identified with a “Return Material Goods” number. Such returns are subject to a minimum of a \$50.00 or 20% restocking fee, whichever is greater. **Approval of equipment for return is fully at the discretion of ENMET.** All requests for return/exchange must be made no later than 30 days of the original shipping date from *ENMET*. The actual amount of any resulting credit will not be determined prior to a complete inspection of the equipment by *ENMET*. Calibration gas cylinders cannot be returned or restocked due to the Department of Transportation refill restrictions. Air Filtration Systems (AFS series & parts) cannot be returned or restocked because their internal surfaces and filters are not amenable to re-inspection.

Certain products, such as stationary systems, or instruments with custom sensor configuration (non-standard) are built to order, and cannot be returned. Cancellation of orders for custom-built products, prior to shipment, will result in the assessment of a cancellation fee. The amount of the cancellation fee will be based upon the size and complexity of the order, and the percentage of total cost expended prior to cancellation.

8.6 Returning an Instrument for Service Instructions

Contact the ENMET Service Department for all service requests.

Phone: 734-761-1270

Email: repair@enmet.com

Fill out the “Service Request Form” found at the end of this manual and return with your instrument for all needs. Please send your instrument for service to the site in which the product was purchased. A new “Service Request Form” may be requested if the one found in the manual is not available. All instruments should be shipped prepaid to ENMET.

Address for Service:

Michigan Location:

ENMET
Attention: Service Department
680 Fairfield Court
Ann Arbor, MI 48108

Kentucky Location:

ENMET
62 Corporate Court
Bowling Green, KY 42103

Providing the “Service Request Form” assists in the expedient service and return of your unit and failure to provide this information can result in processing delays. *ENMET* charges a one hour minimum billing for all approved repairs with additional time billed to the closest tenth of an hour. All instruments sent to *ENMET* are subject to a minimum evaluation fee, even if returned unrepared. Unclaimed instruments that *ENMET* has received without appropriate paperwork or attempts to advise repair costs that have been unanswered after a period of 60 days may, be disposed of or returned unrepared COD and the customer will be expected to pay the evaluation fee. Serviced instruments are returned by UPS/FedEx Ground and are not insured unless otherwise specified. If expedited shipping methods or insurance is required, it must be stated in your paperwork.

NOTE: Warranty of customer installed components.

For Warranty Repairs, please reference *ENMET*’s “Warranty Information and Guidelines” (found earlier in this section).

Mailing/Shipping Address:

ENMET
680 Fairfield Court
Ann Arbor, MI 48108
repair@enmet.com



Phone: 734.761.1270
Fax: 734.761.3220

Service Request Form

Product Name or Number:

Product Serial Number:

Describe Problem or Needed Service:

Warranty Claim? Yes No

CUSTOMER INFORMATION

Billing Address:

Shipping Address:

Contact Name:

Phone #:

Email:

Fax #:

PO/Reference

#:

PAYMENT METHOD

COD

VISA/MasterCard

American Express

Card Number

Exp. Date

Security Code:

Name as it Appears on

Card:

RETURN SHIPPING METHOD

UPS Ground

UPS 3 Day
Select

UPS Next Day
Air

UPS ND Air
Saver

UPS 2 Day Air

UPS Account #:

FedEx Ground

FedEx Air
Express Saver

FedEx Air
Overnight Std.

FedEx Air 2
Day

FedEx Air
Overnight P-1

FedEx Account #:

Insure Shipment: Yes No

Insurance \$
Amount: _____