

**ENMET Corporation**  
**PO Box 979**  
**Ann Arbor, MI 48106-0979**

**MX32 ENGUARD**  
**Operation and Maintenance**  
**Manual**

**Manual Part Number**  
**80003-040**

**MCN-370, 05/30/07**



# Table of Contents

<b>1.0 INTRODUCTION</b> .....	<b>1</b>
1.1 UNPACK.....	1
1.2 CHECK ORDER.....	1
1.3 SERIAL NUMBERS.....	1
<b>2.0 FEATURES</b> .....	<b>2</b>
2.1 MX32 CONTROL ELEMENTS.....	2
2.2 FRONT PANEL FEATURES.....	3
<b>3.0 INSTALLATION</b> .....	<b>5</b>
3.1 MOUNTING MX32 CONTROL.....	5
3.2 WIRING THE MX32 CONTROL.....	6
3.2.1 Relay Contacts.....	6
3.2.2 Wiring Requirements.....	6
4-20 Sensor/Transmitter.....	8
<b>4.0 OPERATION</b> .....	<b>9</b>
4.1 FRONT PANEL PUSHBUTTON SWITCHES.....	9
4.2 DISPLAY AT START-UP.....	10
4.3 DISPLAY CYCLE OF CHANNEL MEASUREMENTS.....	11
4.3.1 Display of No Measurements Mode.....	11
4.3.2 Display of a Single Channel Mode.....	11
<b>5.0 MAINTENANCE</b> .....	<b>12</b>
5.1 ENTER THE MAINTENANCE MENUS.....	12
5.1.1 Entering the Maintenance Menus.....	12
5.1.2 Exit the Maintenance Menus.....	12
5.1.3 MX32 CONTROL Sequence of Maintenance Menus.....	13
5.2 PROGRAMMING MENU.....	14
5.3 INITIALIZATION (INI) MENU.....	17
5.4 CALIBRATION MENU MX32 CONTROL.....	18
5.4.1 Calibration Following an Initialization Non Oxygen Transmitter.....	18
5.4.2 Calibration For regular preventive maintenance.....	19
5.5 CHANGING ACCESS CODE.....	20
5.6 BUZZER MENU.....	20
<b>6.0 WARRANTY</b> .....	<b>21</b>

## List of Illustrations

<b>FIGURE 1: MX32 FEATURES</b> .....	<b>2</b>
<b>FIGURE 2: MX32 FRONT PANEL</b> .....	<b>3</b>
<b>FIGURE 3: MX32 DISPLAY</b> .....	<b>4</b>
<b>FIGURE 4: MOUNTING MX32</b> .....	<b>5</b>
<b>TABLE 1A: FAULT AND ALARM RELAY SETTING</b> .....	<b>6</b>
<b>FIGURE 5: MX32 CONTROL MAIN POWER AND CHANNEL BOARD</b> .....	<b>7</b>
<b>TABLE 1: WIRING TERMINAL</b> .....	<b>8</b>
<b>TABLE 2: WIRING FOR A TWO WIRE S/T</b> .....	<b>8</b>
<b>TABLE 3: WIRING FOR A THREE WIRE S/T</b> .....	<b>8</b>
<b>TABLE 4: MX32 CONTROL SEQUENCE OF MAINTENANCE MENUS</b> .....	<b>13</b>



## 1.0 Introduction

The **MX32 CONTROL** unit can monitor one or two independent channels. Each channel is connected to one sensor/transmitter.

The measurement output from the sensor is displayed on the **MX32 CONTROL** unit and compared with preset alarm thresholds. If the thresholds are exceeded, the control unit activates audio alarms, visual alarms and relays that may be used to control external devices.

**NOTE:** *All specifications stated in this manual may change without notice.*

### 1.1 Unpack

Unpack the **MX32 CONTROL** and examine it for shipping damage. If such damage is observed, notify both **ENMET** customer service personnel and the commercial carrier involved immediately.

#### Regarding Damaged Shipments

**NOTE: It is your responsibility to follow these instructions. If they are not followed, the carrier will not honor any claims for damage.**

- This shipment was carefully inspected, verified and properly packaged at our company and delivered to the carrier in good condition.
- When it was picked up by the carrier at **ENMET**, it legally became your company's property.
- If your shipment arrives damaged:
  - Keep the items, packing material, and carton "As Is." Within 5 days of receipt, notify the carrier's local office and request immediate inspection of the carton and the contents.
  - After the inspection and after you have received written acknowledgment of the damage from the carrier, contact **ENMET** Customer Service for return authorization and further instructions. Have your Purchase Order and Sales Order numbers available.
- ENMET** either repairs or replaces damaged equipment and invoices the carrier to the extent of the liability coverage, usually \$100.00. Repair or replacement charges above that value are your company's responsibility.
- The shipping company may offer optional insurance coverage. **ENMET** only insures shipments with the shipping company when asked to do so in writing by our customer. If you need your shipments insured, please forward a written request to **ENMET** Customer Service.

#### Regarding Shortages

If there are any shortages or questions regarding this shipment, please notify **ENMET** Customer Service within 5 days of receipt at the following address:

**ENMET Corporation**  
680 Fairfield Court  
Ann Arbor, MI 48108  
734-761-1270 734-761-3220 Fax

### 1.2 Check Order

Check the contents of the shipment against the purchase order. Verify that the **MX32 CONTROL** is received as ordered. If there are accessories on the order, ascertain that they are present. Check the contents of calibration kits. Notify **ENMET** customer service personnel of any discrepancy immediately.

### 1.3 Serial Numbers

Each **MX32 CONTROL** is serialized. These numbers are on tags on the equipment and are on record in an **ENMET** database.

## 2.0 Features

### 2.1 MX32 Control elements

The **MX32 CONTROL** unit is made up of the following elements:

- Enclosure rated IP 65, NEMA-12, 12K.
- Hinged smoke gray viewing cover.
- Main power and channel board, that has terminals for power, sensors and relays. Located under access cover.
- Display board, attached to front panel.
- Front panel with display, alarm LEDs, buzzer (horn) and pushbutton switches.

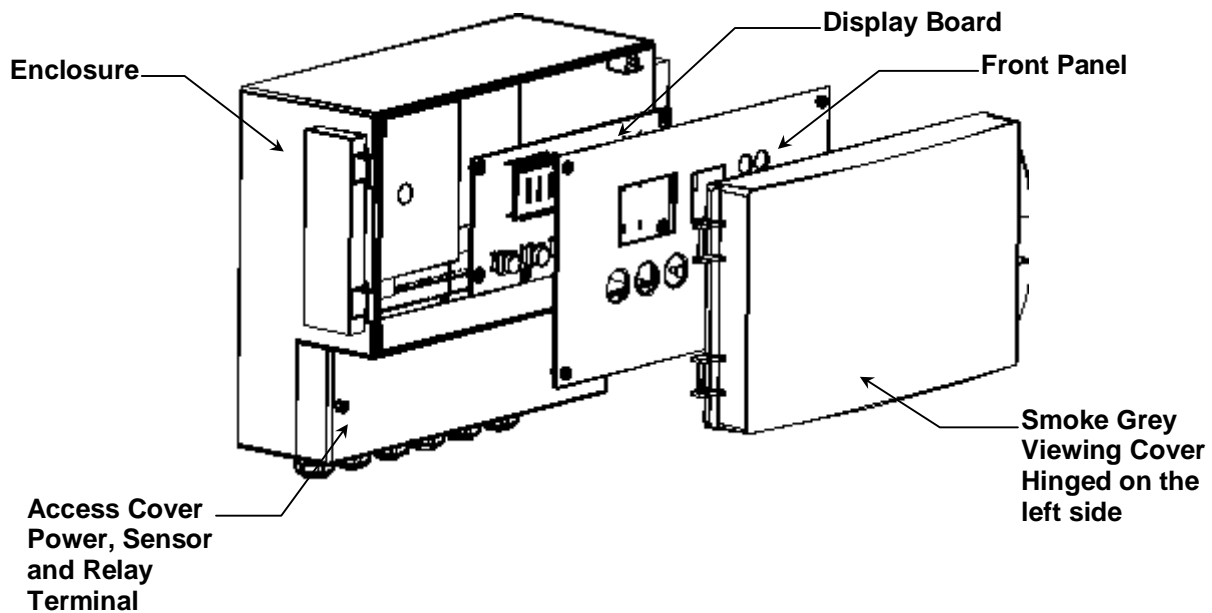

Figure 1: MX32 Features

## 2.2 Front panel features

See Figure 2 for location of features.

LED	Description
<b>Display/Operation</b> [ Lighting bolt on front panel ]	Green LED <ul style="list-style-type: none"> <li>▪ When the green LED is blinking the channel is in program mode.</li> <li>▪ When the green LED is on steady the channel is in operation.</li> </ul>
<b>AL1</b> [ Bell on front panel ]	Alarm 1 red LED when in alarm
<b>AL2</b> [ Bell on front panel ]	Alarm 2 red LED when in alarm
<b>Fault / Calibration / Program</b> [ Wrench on front panel]	Lower most yellow LED <ul style="list-style-type: none"> <li>▪ When the yellow LED is on steady, it indicates a malfunction on the line.</li> <li>▪ When the yellow LED is blinking the channel is in calibration or program mode.</li> </ul>

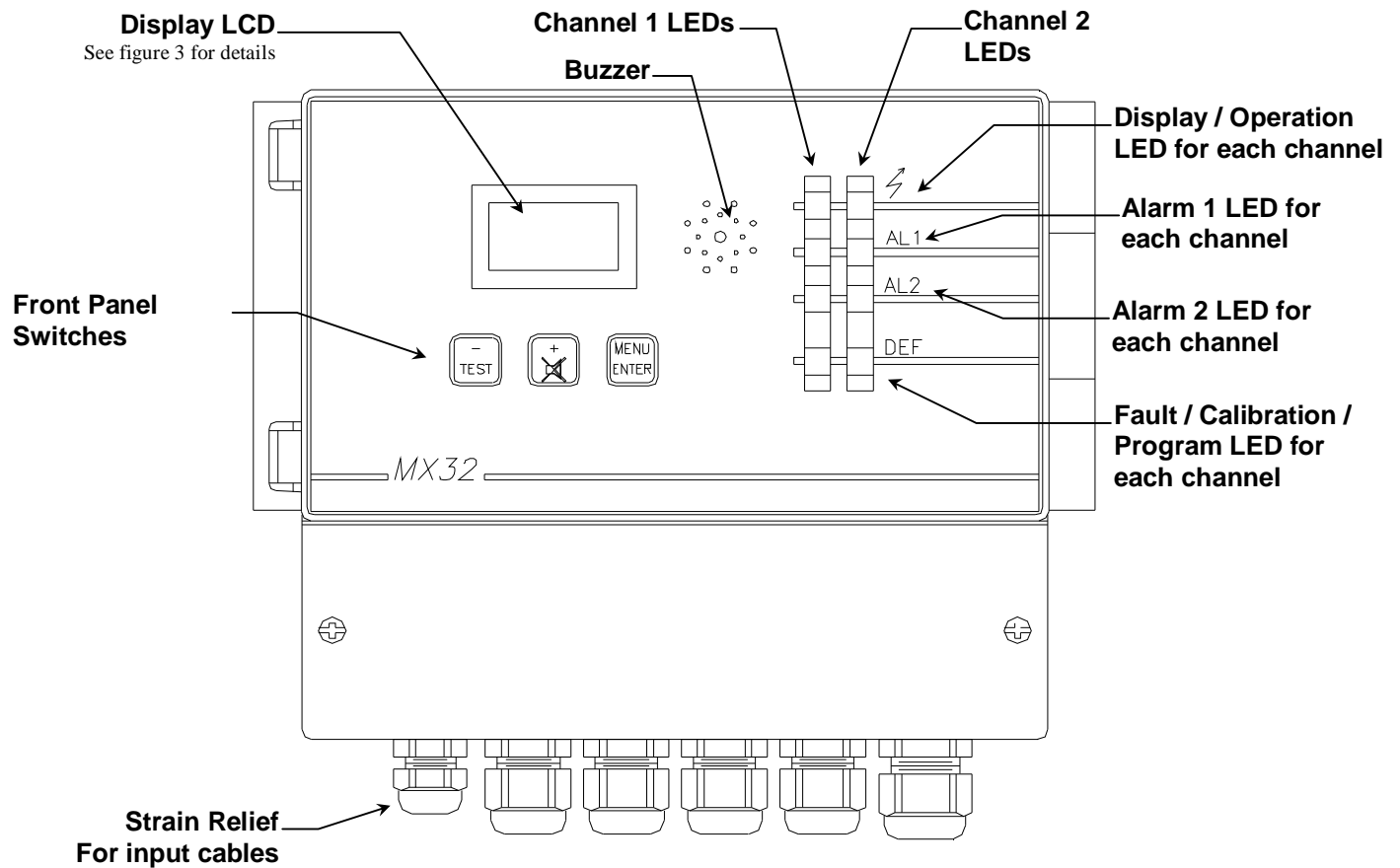
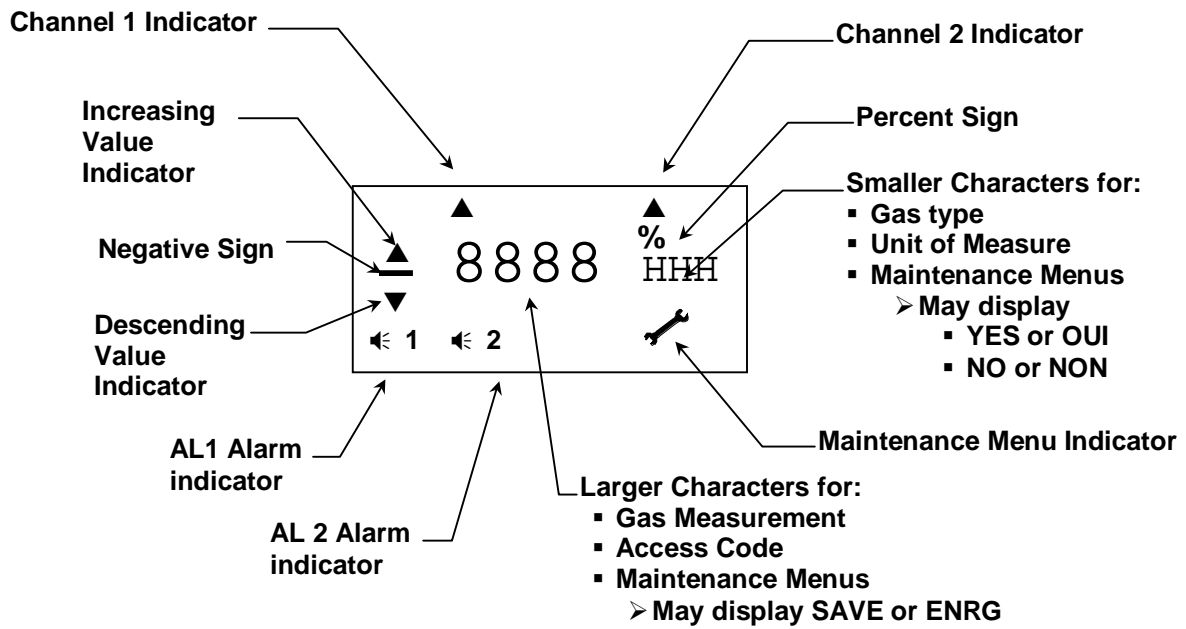

Figure 2: MX32 Front Panel



**Figure 3: MX32 Display**

**NOTE:** In some applications, slight electronic noise between the Sensor/Transmitter and the Control can cause fluctuations in the display reading. These minor fluctuations are considered to be insignificant in terms of the range, detection limit and alarm values of the gas being monitored.



### 3.0 Installation

The **MX32 CONTROL** can be installed in any indoor area that is not classified a hazardous atmosphere. It should preferably be placed in a ventilated and monitored location, such as guardhouse, control room, instrumentation room, etc.

NOTE: To be able to fully open the hinged front cover of the **MX32 CONTROL**, allow space for opening the viewing cover.

#### 3.1 Mounting MX32 Control

The **MX32 CONTROL** is mounted to the wall with 3 screws. Dimensions are given in inches in Figure 4. Dimensions are also marked on the rear of the enclosure in mm.

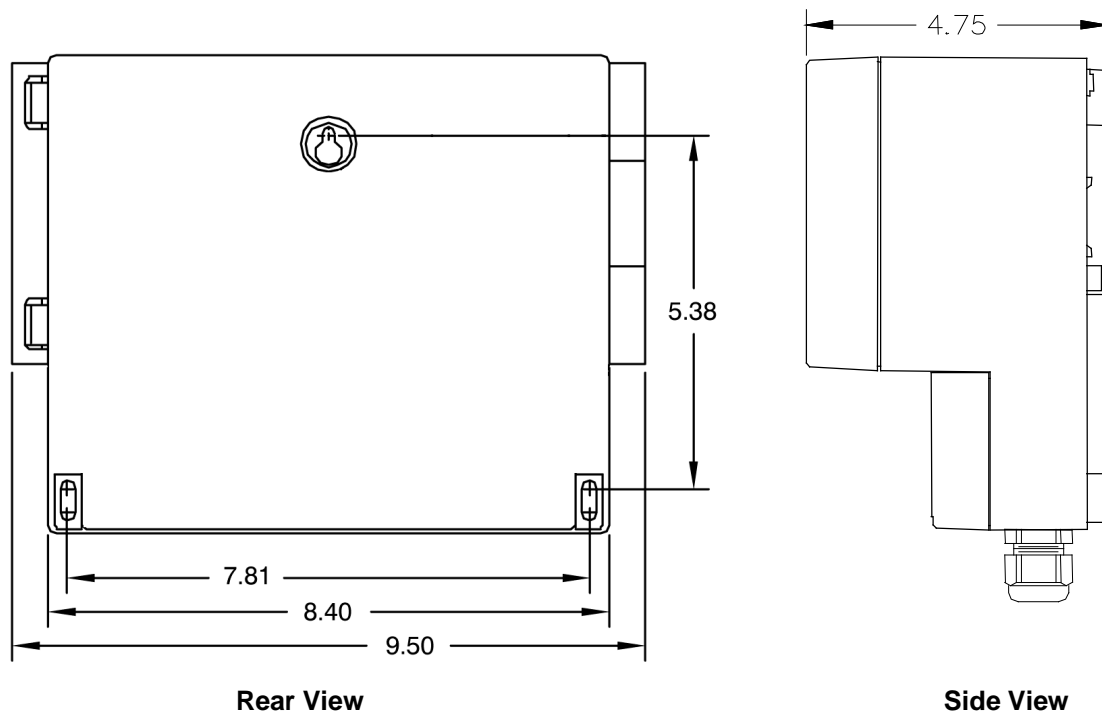

Figure 4: Mounting MX32

### 3.2 Wiring the MX32 Control

The electrical installation should conform to appropriate electrical codes, such as the National Electrical Code in the United States.

**WARNING:** The compliance of the installation to appropriate codes is not *ENMET's* responsibility.

The **MX32 CONTROL** should be powered through circuit breakers provided for this purpose.

**WARNING:** Continuous gas detection and alarm systems (110VAC/220VAC / 24VDC/12VDC powered) become inoperative upon loss of primary power. Contact factory for specifications and pricing of backup battery systems.

Each channel of the **MX32 CONTROL** has a terminal strip to which all wiring for that channel is connected. A typical two-channel circuit board is shown in Figure 5 and wiring for this terminal is shown in Table 1.



#### 3.2.1 Relay Contacts

**MX32 CONTROL** relay contacts for the first two alarm levels are on the RL, 1, RL and 2 positions of each channel terminal strip, as indicated in Figure 5 and Table 1. There are 3-pin headers for setting relays to normally open or normally closed operation. The location of these headers is indicated in Figure 5. To set the relays, place the jumpers on the position 2 & 3 pins for NO operation or positions 1 & 2 for NC operation. These jumpers are placed in the NC operation positions at the factory. See Table 1a. These relays have a maximum capacity of 2 Amp at 230 Volts.

The Fault Relay (DEF), system alarm relay contacts are on the main board, as shown in Figure 5.

Auxiliary alarms should be powered from an independent power source separate form the instrument power to avoid alarm failure due to controller malfunction.

**Table 1a: Fault and Alarm Relay Setting**

Jumper Position	Relay setting
3-pin header  Pin # 1 2 3 2-pin jumper	3-pin header located near associated relay: Fault relay (DEF) = J103 Channel 1 – AL1 relay = J105, AL2 relay = J101 Channel 2 – AL1 relay = J108, AL2 relay = J107 See Figure 5 for location of each 3-pin header.
 Jumper on pins 1 & 2	Jumper on pins 1 and 2 relay NC operation (no power and alarm condition) (Factory Setting)
 Jumper on pins 2 & 3	Jumper on pins 2 and 3 relay NO operation

#### 3.2.2 Wiring Requirements

**Sensor/Transmitters:** Wiring to the Sensor/Transmitters should be by two or three wire shielded cable. The recommended cable is 18 gauge three wire, *ENMET* part number 66017-006, Alpha-1747C or equivalent.

**Output Loop:** Wiring to output loop should be similar two wire shielded cable.

**Relay:** Relay wiring can be suitable insulated wire.

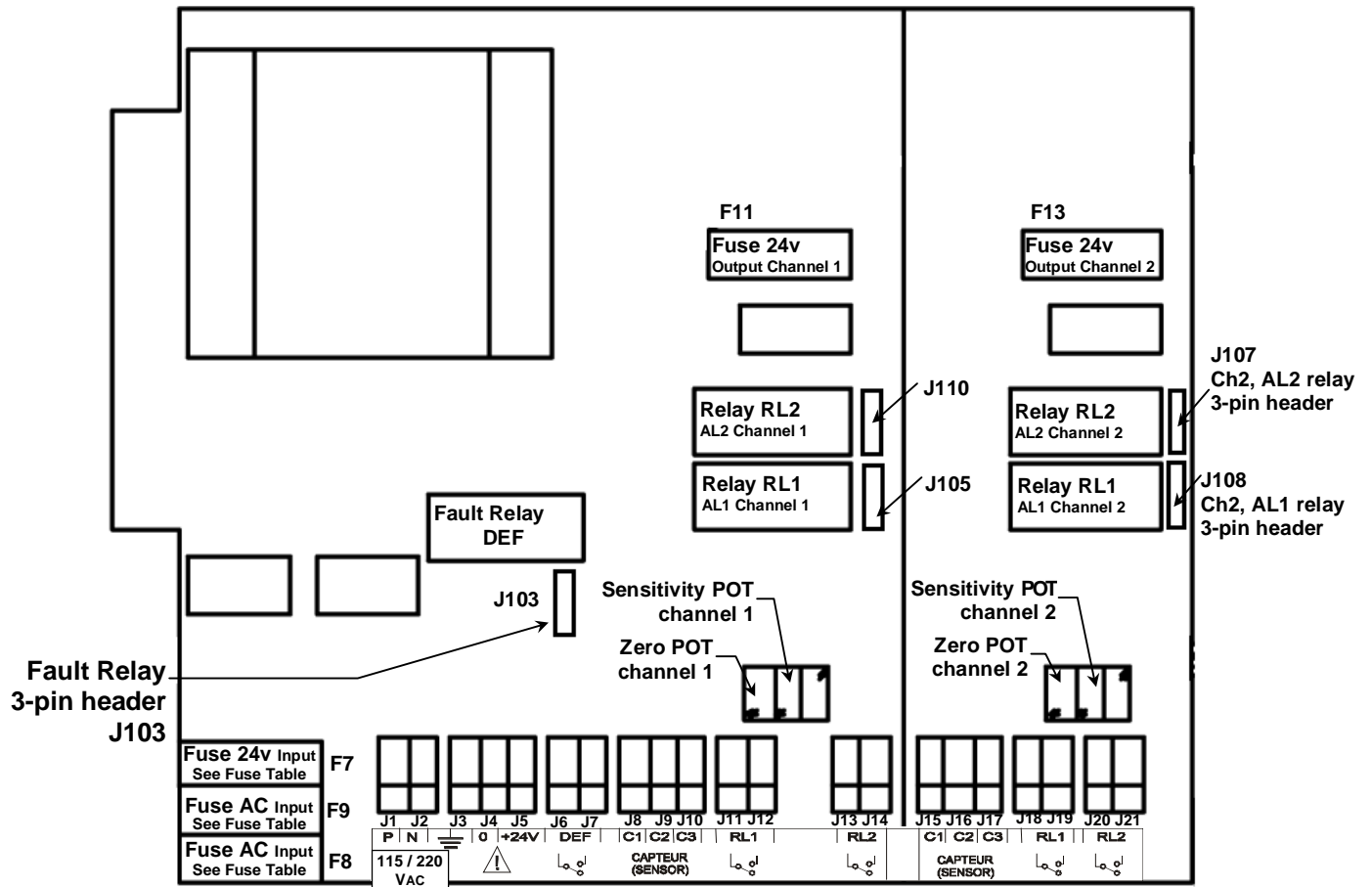



Figure 5: MX32 CONTROL Main Power and Channel Board

MX32 CONTROL Fuse Table		
<b>F7</b>	<b>24v Input</b>	1.25A Time delay
<b>F9,F8</b>	<b>for 115VAC Input</b>	315mA Time delay
<b>F9,F8</b>	<b>for 230VAC Input</b>	160mA Time delay
<b>F11,F13</b>	<b>24v Output</b>	400mA Time delay

**Table 1: wiring terminal**

Ref Label	Terminal Label	Wiring
P	J1	Input, AC high
N	J2	Input, AC neutral
	J3	Ground
0	J4	Input, DC minus
+24V	J5	Input, DC positive
DEF	J6	Fault relay*
	J7	Fault relay*
C1	J8	Channel 1, Sensor signal – (See Table 2, 3 for 2 or 3 wire S/T)
C2	J9	Channel 1, Sensor ground if used (See Table 2, 3 for 2 or 3 wire S/T)
C3	J10	Channel 1, Sensor + (See Table 2, 3 for 2 or 3 wire S/T)
RL1	J11	Channel 1, Alarm 1 relay*
	J12	Channel 1, Alarm 1 relay*
RL2	J13	Channel 1, Alarm 2 relay*
	J14	Channel 1, Alarm 2 relay*
C1	J15	Channel 2, Sensor signal – (See Table 2, 3 for 2 or 3 wire S/T)
C2	J16	Channel 2, Sensor ground if used (See Table 2, 3 for 2 or 3 wire S/T)
C3	J17	Channel 2, Sensor + (See Table 2, 3 for 2 or 3 wire S/T)
RL1	J18	Channel 2, Alarm 1 relay*
	J19	Channel 2, Alarm 1 relay*
RL2	J20	Channel 2, Alarm 2 relay*
	J21	Channel 2, Alarm 2 relay*

\* See Table 1a for setting relays to NO or NC operation.

#### 4-20 Sensor/Transmitter

Sensor/Transmitters are connected to positions C1, C2 and C3 on each channel terminal strip. Connections are shown in Table 2 for two wire S/T and Table 3 for three wire S/T. See Figure 5 for location of channel terminal strips.

**Table 2: Wiring for a Two Wire S/T**

Two Wire Sensor/Transmitter	
C1	Signal minus (–)
C2	Not used
C3	Signal plus, +24VDC power

**Table 3: Wiring for a Three Wire S/T**

Three wire Sensor/Transmitter	
C1	Signal
C2	Ground
C3	+24VDC power

## 4.0 Operation

The **MX32 CONTROL** display is independent of the LEDs and relays for each channel.

When a visual or audio alarm is activated, *the display does not automatically display the channel in alarm.*

### 4.1 Front Panel Pushbutton Switches

Three pressure switches (buttons) on the **MX32 CONTROL FRONT** panel.

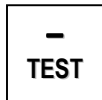
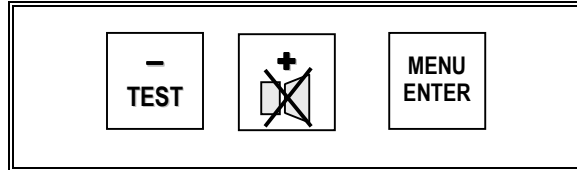

Manual display of other channel (if 2 channels)  
 Manual display of previous menu  
 Decrease value of a digit while setting a value  
 Combined with “+” switch to step through normal display cycle

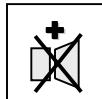

Manual display of other channel (if 2 channels)  
 Manual display of next menu  
 Increase value of a digit while setting a value  
 Combined with “-” switch to step through normal display cycle



To enter maintenance menus  
 ENTER

## 4.2 Display at start-up

When power is supplied to the **MX32 CONTROL**, the unit goes through a self-test sequence as follows:

1. Current software version and buzzer test.

*Examples of Display:*

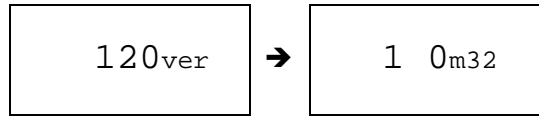

2. Current menu access code.

*Example of Display:*

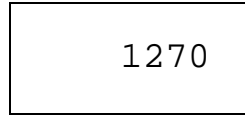

See section 5.0 for Maintenance Menus  
Section 5.5 for Access Code

3. Current AL1 threshold displayed for channel 1, while the AL1 and fault light for channel 1 light up.

*Example of Display:*

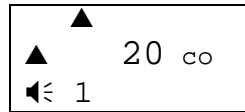

4. Current AL2 threshold displayed for channel 1, while the AL2 and fault light for channel 1 light up.

*Example of Display:*

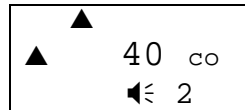

5. Current AL1 threshold displayed for channel 2, while the AL1 and fault light for channel 2 light up.

*Example of Display:*

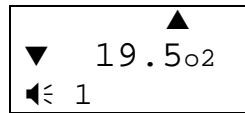

6. Current AL2 threshold displayed for channel 2, while the AL2 and fault light for channel 2 light up.

*Example of Display:*

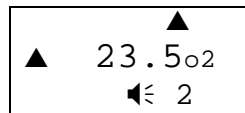

7. Count down (in seconds), time for the sensor(s) to stabilize, and both fault LED are lit.

*Example of Display:*

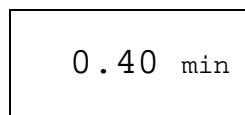

This time is programmed at the factory for best results. See section 5.2 to change programmed setting.

8. Then the **MX32 CONTROL** will begin the normal display cycle

*Examples of Display:*

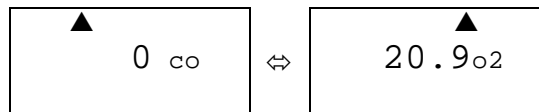

See section 4.4 for Normal Display Cycle

### 4.3 Display Cycle of Channel measurements

**CAUTION:** The display and audio alarms operate independently. *When an audio and visual alarm are active the display does not automatically switch to the channel in alarm.*

#### 4.3.1 Display of No Measurements Mode

No measurements displayed.

By pressing both the – & + switches at the same time the display changes to no measurement display mode.

*Example of the no measurement Display:*

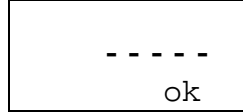

The display will remain in the no measurement mode until the + & – switches are pressed at the same time to change to the single channel display mode.

In the no measurement mode to display a channel manually press the + or – switch.

*Examples of typical Display:*

Press – to display channel 1 for 1 minute

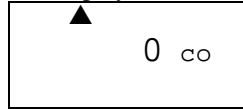

*Examples of typical Display:*

Press + to display channel 2 for 1 minute

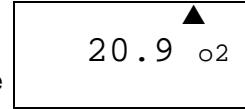

After about 1 minute, the display returns to the no measurement display mode.

#### 4.3.2 Display of a Single Channel Mode

The display will remain in the channel selected by pressing the + or – switch.

By pressing both the – & + switches at the same time a second time, the display changes to a single channel display mode.

By pressing the – switch, the display is manually changed to channel 1 and will continue to display channel 1 until the + switch is pressed. By pressing the + switch, the display is manually changed to channel 2 and will continue to display channel 2 until the – switch is pressed.

*Examples of typical Display:*

Press – to display channel 1

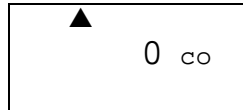

Press + to display channel 2

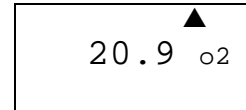

To return to the normal display mode press the – and + switches at the same time once more.

## 5.0 Maintenance

The **MX32 CONTROL** unit has 5 maintenance menus that are accessed by pressing the MENU switch and entering a valid access code. The access code is set at the factory and may be changed by following the access code menu explained in section 5.5.

**CAUTION:** The procedures and adjustments described in the following sections must be performed by authorized personal. Failure to follow instructions may jeopardize accurate measurements.

See section 4.1 for a description of the pushbutton switches

NOTE: There may be differences in the display for request to save what has been entered in the maintenance menus.

*Example:*

May display  
ENRG or SAVE

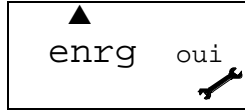

*Example:* May display:  
OUI or YES  
NON or NO

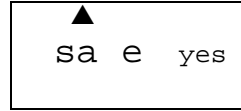

### 5.1 Enter the maintenance menus

When the MENU/ENTER switch is pressed the **MX32 CONTROL** unit will request an access code to enter the maintenance portion for programming, initialization, calibration, changing access code and buzzer setting.

If no switch is pressed for one minute, the **MX32 CONTROL** will return to normal display mode.

#### 5.1.1 Entering the Maintenance Menus

To enter the maintenance menu press the **MENU/ENTER** switch.

If no switch is pressed for one minute, the **MX32 CONTROL** will return to normal display mode.

The request for Access Code display appears. The Access Code set at the factory is 1270.

*Example of Displays*

The first digit will be flashing.

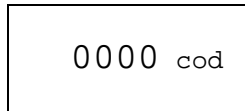

To enter the access code. Press + or – to select value of digit

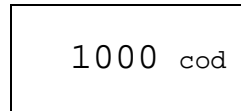

Press ENTER to move to next digit.

Press + or – to select value of digit  
Press ENTER to move to next digit

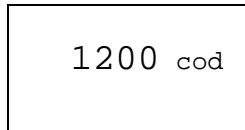

Press + or – to select value of digit  
Press ENTER to move to next digit

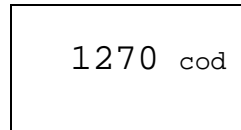

When access code is complete, press ENTER.

- If the access code is invalid, the display will return to the normal mode.
- If the access code is valid, the display will enter the maintenance menus

See Table 4 for the sequence of maintenance menus and a description of their uses. Press the + switch to move to the next menu or the – switch to move back to the previous menu.

#### 5.1.2 Exit the Maintenance Menus

To exit the maintenance menus at any point:

Press + & – switches at the same time. The EnrG display will appear.

Press + & – to go to the save (exit) display

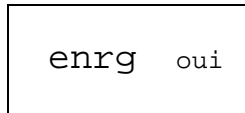

Press + or – to select OUI (yes) or NON (no). Press ENTER

Press + or – to select yes or no

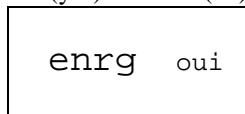

The **MX32 CONTROL** will return to the normal display mode.

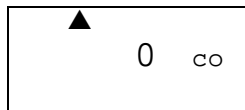



### 5.1.3 MX32 CONTROL Sequence of Maintenance Menus

See Table 4 for the sequence of maintenance menus and a description of their uses.

Press the + switch to move to the next menu (↓) or the – switch to move back to the previous menu (↑).

**Table 4: MX32 Control Sequence of Maintenance Menus**

Menu	Description	Display (flashing)
Access Code	The key used to enter the maintenance menus.	0000 cod
Enter Valid Code ↓	See section 5.1.1	
Programming	Used to program the parameters of a measurement channel. See section 5.2	prg
Press + ↓ or – ↑		
Calibration * Factory set Do Not use without consulting <b>ENMET</b> Corp	Used to check and make adjustments to zero (clean air) and calibration gas. See section 5.4	CAL
Press + ↓ or – ↑		
Initialization * Factory set Do Not use without consulting <b>ENMET</b> Corp	Used to initialize the measurement curve managed by the microprocessor with a sensor. See section 5.3	ini
Press + ↓ or – ↑		
Access Code Change	Used to change the access code for entering the maintenance menus. See section 5.5	% cod
Press – ↑		
Buzzer	Used to set the buzzer active or inactive. See section 5.6	buz

\* **CAUTION: Do Not** enter without first consulting **ENMET** Corporation.

***Improper use will cause the MX32 to be Non-Functional***

Use + to by pass this function.

## 5.2 Programming menu

To set a channel active or inactive, gas to be measured, alarm thresholds, relay timing and sensor type.

See section 5.1.1 to enter a valid access code to enter the maintenance menus. Press the + switch to move through the maintenance menus until the PRG is flashing.

### 1. Press ENTER switch while PRG is flashing to enter programming menu

Press ENTER

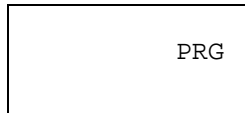

Press + or - to select channel to be programmed.

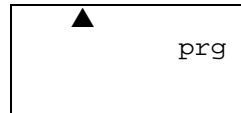

When the channel indicator is correct, Press ENTER

The wrench symbol will appear in the lower right corner of the display and the yellow LED of the corresponding channel is flashing, indicating the **MX32 CONTROL** is in maintenance mode and the relays are inhibited.

### 2. Select ON or OFF, if the channel is to be active or inactive. The on or off will be flashing.

Press + or - to select ON or OFF

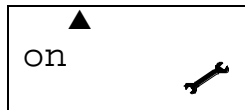

Press ENTER when correct state is selected

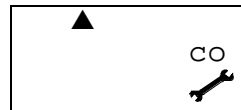

Next the symbol for the gas to be measured will be flashing

### 3. Select the gas to be measured by scrolling through the symbols until the proper symbol appears on the display.

Press + or - to move through the symbols

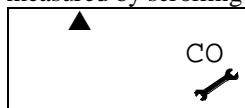

Press ENTER when correct symbol is selected

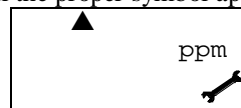

Next the symbol for the unit of measure will be flashing

### 4. Select the symbol for unit of measure by scrolling through the symbols until the proper symbol appears on the display.

Press + or - to move through the symbols

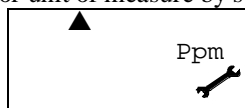

Press ENTER when correct symbol is selected

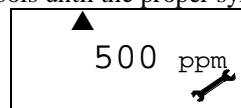

Next the measurement scale will be flashing

### 5. For measurement scale Press + to change digit value and ENTER to move to next digit.

Press + or - to modify the scale digit by digit

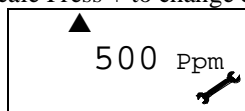

Press ENTER when correct scale is selected

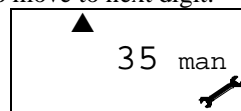

Next the decimal placement

### 5a. For measurement scale decimal point Press + to change position and ENTER to move to next digit.

Press + or - to modify the decimal place

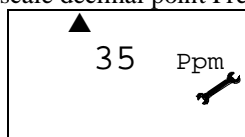

Press ENTER when correct decimal place is selected

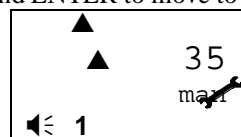

Next the AL1 threshold will be flashing

### 6. This display indicates the Alarm threshold 1 and manual clearance. The red LED for the corresponding alarm is lit.

To modify the alarm threshold AL1 if necessary, Press + to change digit value and ENTER to move to next digit.

Press + or - to modify the alarm digit by digit

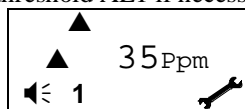

Press ENTER when correct threshold is selected

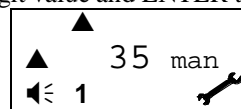

Next the increasing decreasing indicator is flashing

### 7. Press + or - to select increasing or decreasing alarm type. Press ENTER

Press + for increasing  
Press - for decreasing

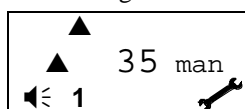

Press ENTER when correct alarm type is selected

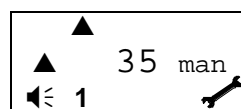

Next the MAN or AUT is flashing

NOTE: The change may or may not be indicated on the display.

**Manual alarm clearing:** If the gas content drops below the preset alarm threshold again this alarm must be cleared manually by pressing the + (clear alarm) switch.

**Automatic alarm clearing:** If the gas content drops below the pre-set alarm threshold again the relay will be automatically cleared.

8. Press + or – to select manual (MAN) or automatic (AUT) mode for alarm clearing. Press ENTER

Press + or – to select alarm clear mode

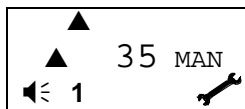

Press ENTER when correct alarm clear mode is selected

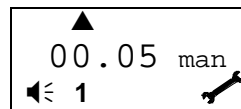

Next the relay delay time (in minutes) is flashing

When the alarm threshold is exceeded the time delay is counted down then the alarms (buzzer and LED) are activated the relay is activated. Use a 0 min setting for an instantaneous relay activation, this may cause nuisance alarms.

9. Press + or – to select time delay (in minutes) for alarm 1 relay. Press ENTER

Press + or – to modify the time digit by digit

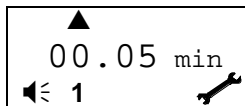

Press ENTER when correct time is selected

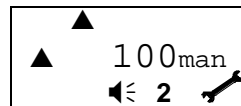

Next alarm AL2 threshold will be flashing

10. This display indicates the Alarm threshold 2 and manual clearance. The red LED for the corresponding alarm is lit. To modify the alarm threshold AL2 if necessary, Press + to change digit value and ENTER to move to next digit.

Press + or – to modify the alarm digit by digit



Press ENTER when correct threshold is selected

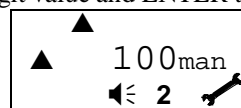

Next the increasing decreasing indicator is flashing

11. Press + or – to select increasing or decreasing alarm type. Press ENTER

Press + for increasing  
Press – for decreasing

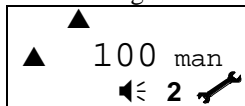

Press ENTER when correct alarm type is selected

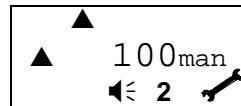

Next the MAN or AUT is flashing

NOTE: The change may or may not be indicated on the display.

**Manual alarm clearing:** If the gas content drops below the preset alarm threshold again this alarm must be cleared manually by pressing the + (clear alarm) switch.

**Automatic alarm clearing:** If the gas content drops below the pre-set alarm threshold again the relay will be automatically cleared.

12. Press + or – to select manual (MAN) or automatic (AUT) mode for alarm clearing. Press ENTER

Press + or – to select alarm clear mode



Press ENTER when correct alarm clear mode is selected

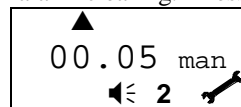

Next the relay delay time (in minutes) is flashing

When the alarm threshold is exceeded the time delay is counted down then the alarms (buzzer and LED) are activated the relay is activated. Use a 0 min setting for an instantaneous relay activation, this may cause nuisance alarms.

13. Press + or – to select time delay (in minutes) for alarm 2 relay. Press ENTER

Press + or – to modify the time digit by digit

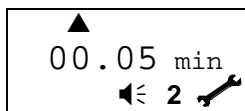

Press ENTER when correct time is selected

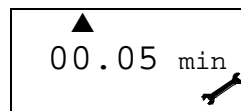

Next the fault relay time delay will be flashing

14. Press + or – to select time delay (in minutes) for alarm Fault relay. Press ENTER

Press + or – to modify the time digit by digit

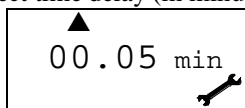

Press ENTER when correct time is selected

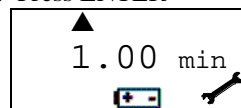

Next the stabilization time count down at start up will be flashing

15. Press + or – to select the stabilization time at start up. Press ENTER

Press + or – to modify the time digit by digit

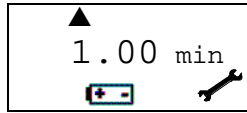

Press ENTER when correct time is selected

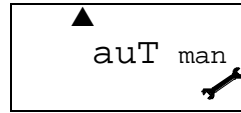

Next the sensor type will be flashing  
May display: OtH

16. Press + or – to scroll through the different types of sensor *if necessary*. Press ENTER

Press + or – to modify the type  
See choices below



Press ENTER when correct sensor type is selected

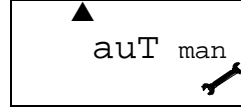

Next the MAN or AUT will be flashing

- OtH** or AUT = Other, for toxic or Oxygen (for 4-20mA Sensor/Transmitter)
- Fl rE** or InC = ionic, optical etc... (not used)
- EHP or EHP = Combustible (not used)
- br d** or POnT = Bridge (not used)

17. Press + or – to select MAN or AUT. Press ENTER

MAN: no visual alarm, yellow LED flashing, when s/t is in calibration mode

AUT: visual alarm, yellow LED flashing, when s/t is in calibration mode

Press + or – to select MAN or AUT

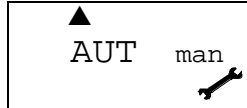

Press ENTER when correct choice is selected

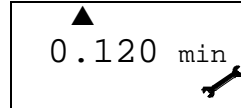

Will be displayed  
Press ENTER 4 times

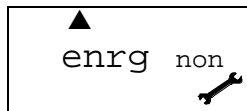

Next the save (update) programming will be flashing

18. Press + or – to select OUI (yes) or NON (no). To update the programming for the channel, Press ENTER

If you select NON and press ENTER the programming will not be updated.

If you select OUI and press ENTER the programming will be updated.

Press + or – to select yes or no

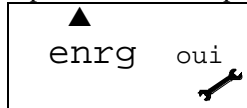

Press ENTER when correct choice is selected



Next the MX32 Control returns to the normal display mode.

19. Programming is complete the **MX32 CONTROL** display returns to normal display mode.

### 5.3 Initialization (INI) menu

**CAUTION:** This procedure is *not* used with 4 – 20mA Sensor/Transmitters. Continue to the next menu.

This menu is used to automatically INITIALIZE the measurement curve managed by the microprocessor of sensor connected to the channel.

Initialization should be done when the unit is first installed and when a cell or sensor is replaced.

See section 5.1.1 to enter a valid access code to enter the maintenance menus. Press the + switch to move through the maintenance menus until the INI is flashing.

1. Press ENTER switch while INI is flashing to enter initialization menu

Press ENTER

A rectangular LCD display showing the text "ini" in the center.

Next the channel indicator is flashing.

2. Press + or – to Select channel to be initialized.

When the channel indicator is correct. Press ENTER

A rectangular LCD display showing the text "ini" in the center. A small black triangle cursor is positioned above the second character 'i'.

Next the save initialization display is flashing

3. Press + or – to select OUI (yes) or NON (no) for channel initialization to be updated. Press ENTER

Press ENTER

A rectangular LCD display showing the text "enrg oui" in the center. A small black triangle cursor is positioned above the first character 'e'.

4. Initialization is complete the **MX32 Control** display returns to normal display mode.

A rectangular LCD display showing the text "0 co" in the center. A small black triangle cursor is positioned above the first character '0'.

### 5.4 Calibration Menu MX32 CONTROL

**CAUTION:** This procedure is to align the MX32 CONTROL and S/T displays only. Do Not enter without first consulting ENMET Corporation. Calibration of sensors *MUST* be done at the sensor/transmitter, in accordance with the S/T manual.

The S/T for Oxygen does not have a zero point. Therefore, a calibration of the S/T in accordance with the S/T manual should be adequate for alignment.

The MX32 CONTROL calibration menu can be used to check and make *minor adjustments* to the zero and sensitivity of the display compared to the sensor signal.

There are two ways to calibrate the MX32 CONTROL:

- Following an Initialization. See section 5.4.1.
- For regular preventive maintenance of unit. See section 5.4.2.

#### 5.4.1 Calibration Following an Initialization Non Oxygen Transmitter

See section 5.1.1 to enter a valid access code to enter the maintenance menus. Press the + switch to move through the maintenance menus until the CAL is flashing.

1. Press ENTER switch while CAL is flashing to enter the calibration menu.

Press ENTER



Press + or - to select channel to be programmed.

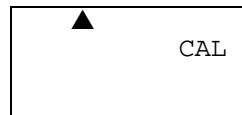

When the channel indicator is correct, Press ENTER

2. Apply clean 20.9 oxygen (clean air) to the sensor. Display will show the current zero value, the XO over the wrench indicates zero adjustment.

3. If necessary (display does not equal Zero) adjust the measurement to Zero by adjusting the Zero Potentiometer corresponding to the channel concerned. See Figure 5 for location of Zero POT. O = 4mA.

Press ENTER

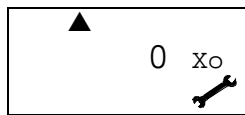

4. Apply calibration gas to the sensor and wait until the signal stabilizes. Display will show the current gas measurement, the XF over the wrench indicates sensitivity adjustment.

**WARNING:** Do not make adjustment or press ENTER without applying calibration gas, a fault condition will be triggered.

5. Press ENTER, to indicate sensitivity adjustment

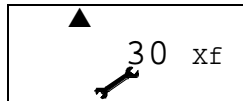

6. If necessary (display does not equal calibration gas) adjust the measurement to the calibration gas by adjusting the Sensitivity Potentiometer corresponding to the channel concerned. See Figure 5 for location of Sensitivity POT.

Press ENTER to update adjustment

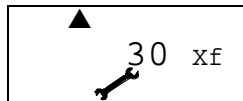

Then the request to save calibration is displayed

7. Press + or - to select OUI (yes) or NON (no) for channel calibration to be updated. Press ENTER.

If you select NON and press ENTER the calibration will not be updated.

If you select OUI and press ENTER the calibration will be updated.

Press ENTER

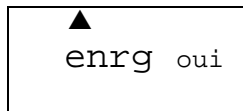

8. Calibration is complete MX32 CONTROL display returns to normal display mode.



**5.4.2 Calibration For regular preventive maintenance**

**CAUTION: This procedure is to align the MX32 CONTROL and S/T displays only. Calibration of sensors *MUST* be done at the sensor/transmitter, in accordance with the S/T manual.**

The S/T for Oxygen does not have a zero point. Therefore, a calibration of the S/T in accordance with the S/T manual should be adequate for alignment.

See section 5.1.1 to enter a valid access code to enter the maintenance menus. Press the + switch to move through the maintenance menus until the CAL is flashing.

1. Press ENTER switch while CAL is flashing to enter the calibration menu.

Press ENTER



Press + or - to select channel to be programmed.

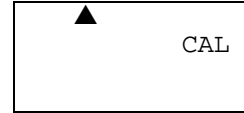

When the channel indicator is correct, Press ENTER

2. Apply clean 20.9 oxygen (clean air) to the sensor.

Display will show the current zero value, the XO over the wrench indicates zero adjustment.

3. If necessary (display does not equal Zero) adjust the measurement to Zero by pressing + or - switches until display shows Zero. Press ENTER.

Press ENTER

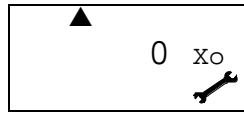

4. Apply Calibration gas to the sensor and wait until the signal stabilizes

Display will show the current gas measurement, the XF over the wrench indicates sensitivity adjustment.

5. Press ENTER, to indicate sensitivity adjustment

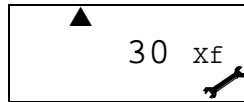

6. If necessary (display does not equal Span) adjust the measurement to the Span by pressing + or - switches until display shows the correct measurement. Press ENTER.

Press ENTER to update adjustment

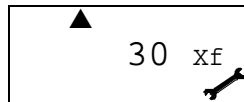

Then the request to save calibration is displayed

7. Press + or - to select OUI (yes) or NON (no) for channel calibration to be updated. Press ENTER.

If you select NON and press ENTER the calibration will not be updated.

If you select OUI and press ENTER the calibration will be updated.

Press ENTER

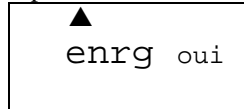

8. Calibration is complete **MX32 CONTROL** display returns to normal display mode.

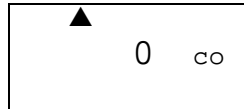

### 5.5 Changing Access Code

This menu allows **MX32 CONTROL** unit access code to be changed.

See section 5.1.1 to enter a valid access code to enter the maintenance menus. Press the + switch to move through the maintenance menus until the % COD is flashing.

Press ENTER switch while the % COD is flashing to enter the access code menu.

The current access code is displayed.

1. Press + or – select value of digit, press ENTER to move to next digit. When access code is complete, press ENTER.

Press + or – to select value of digit  
Press ENTER to move to next digit

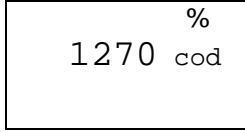

Press + or – to select value of digit  
Press ENTER to move to next digit

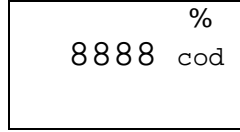

When access code is complete, press ENTER.

Then the request to save new access code is displayed.

2. Press + or – to select OUI (yes) or NON (no). To update the access code, Press ENTER  
If you select NON and press ENTER the new access code will not be updated.  
If you select OUI and press ENTER the new access code be updated.

Press + or – to select yes or no

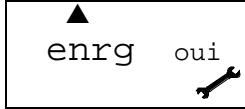

Press ENTER when correct choice is selected

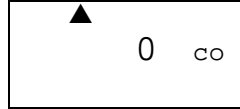

Next the MX32 Control returns to the normal display mode.

- If the access code is invalid, the display will return to the normal mode.
- If the access code is valid, the display will enter the maintenance menus

### 5.6 Buzzer menu

This menu allows **MX32 CONTROL** unit to set the buzzer (horn) active or inactive.

See section 5.1.1 to enter a valid access code to enter the maintenance menus. Press the + switch to move through the maintenance menus until the BUZ is flashing.

1. Press ENTER switch to enter the Buzzer menu.

Press ENTER



2. Press + or – to select ON (buzzer active) or OFF (buzzer is non-active). Press ENTER

Press + or – to select buzzer setting



When the buzzer setting is correct, Press ENTER

3. Press + or – to select OUI (yes) or NON (no) for buzzer setting to be updated. Press ENTER  
If you select NON and press ENTER the buzzer setting will not be updated.  
If you select OUI and press ENTER the buzzer setting will be updated.

Press + or – to select yes or no

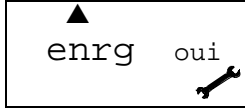

Press ENTER when correct choice is selected

4. Buzzer setting is complete, the **MX32 CONTROL** display returns to normal display mode.

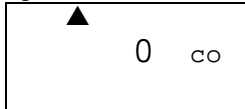



## 6.0 WARRANTY

**ENMET** warrants new instruments to be free from defects in workmanship and material under normal use for a period of one year from date of shipment from **ENMET**. The warranty covers both parts and labor excluding instrument calibration and expendable parts such as calibration gas, filters, batteries, etc... Equipment believed to be defective should be returned to **ENMET** within the warranty period (transportation prepaid) for inspection. If the evaluation by **ENMET** confirms that the product is defective, it will be repaired or replaced at no charge, within the stated limitations, and returned prepaid to any location in the United States by the most economical means, e.g. Surface UPS/FedEx Ground. If an expedient means of transportation is requested during the warranty period, the customer is responsible for the difference between the most economical means and the expedient mode. **ENMET** shall not be liable for any loss or damage caused by the improper use of the product. The purchaser indemnifies and saves harmless the company with respect to any loss or damages that may arise through the use by the purchaser or others of this equipment.

This warranty is expressly given in lieu of all other warranties, either expressed or implied, including that of merchantability, and all other obligations or liabilities of **ENMET** which may arise in connection with this equipment. **ENMET** neither assumes nor authorizes any representative or other person to assume for it any obligation or liability other than that which is set forth herein.

NOTE: When returning an instrument to the factory for service:

- Be sure to include paperwork.
- A purchase order, return address and telephone number will assist in the expedient repair and return of your unit.
- Include any specific instructions.
- For warranty service, include date of purchase
- If you require an estimate, please contact **ENMET** Corporation.

There are Return for Repair Instructions and Form on the last pages of this manual. This Form can be copied or used as needed.

Manual Part Number

80003-040

February 2001

MCN-271, 01/14/02

MCN-278, 06/07/02

MCN-286, 10/02/02

MCN-328, 03/24/05

MCN-330, 04/01/05

MCN-357, 11/13/06

MCN-370, 05/30/07

**Notes:**



PO Box 979  
680 Fairfield Court  
Ann Arbor, Michigan 48106-0979  
734.761.1270 Fax 734.761.3220

# Returning an Instrument for Repair

**ENMET** instruments may be returned to the factory or any one of our Field Service Centers for regular repair service or calibration. The **ENMET** Repair Department and Field Service Centers also perform warranty service work.

When returning an instrument to the factory or service center for service, paperwork must be included which contains the following information:

- A purchase order number or reference number.
- A contact name with return address, telephone and fax numbers
- Specific instructions regarding desired service or description of the problems being encountered.
- Date of original purchase and copy of packing slip or invoice for warranty consideration.
- If a price estimate is required, please note it accordingly *and be sure to include a fax number.*

Providing the above information assists in the expedient repair and return of your unit.

## **Failure to provide this information can result in processing delays.**

**ENMET** charges a one hour minimum billing for all approved repairs with additional time billed to the closest tenth of an hour. All instruments sent to **ENMET** are subject to a minimum \$30 evaluation fee, even if returned unrepaired. Unclaimed instruments that **ENMET** has received without appropriate paperwork or attempts to advise repair costs that have been unanswered, after a period of 60 days, may be disposed of or returned unrepaired COD with the evaluation fee.

Service centers may have different rates or terms. Be sure to contact them for this information.

**Repaired instruments are returned by UPS/FedEx Ground and are not insured unless otherwise specified. If expedited shipping methods or insurance is required, it must be stated in your paperwork.**

**Note:** Warranty of customer installed components.

If a component is purchased and installed in the field, and fails within the warranty term, it can be returned to **ENMET** and will be replaced, free of charge, per **ENMET's** returned goods procedure.

If the entire instrument is returned to **ENMET** Corporation with the defective item installed, the item will be replaced at no cost, but the instrument will be subject to labor charges at half of the standard rate.





# Repair Return Form

Mailing Address:  
ENMET Corporation  
PO Box 979  
Ann Arbor, Michigan 48106

Shipping Address:  
ENMET Corporation  
Attn: Repair Department  
680 Fairfield Court  
Ann Arbor, Michigan 48108

Phone Number: 734.761.1270  
FAX Number: 734.761.3220

---

Your Mailing Address:

Your Shipping Address:

_____	_____
_____	_____
_____	_____
_____	_____

Contact Name: \_\_\_\_\_ Your Phone: \_\_\_\_\_

Your PO/Reference Number: \_\_\_\_\_ Your FAX: \_\_\_\_\_

Payment Terms:  COD  
(Check one)  VISA / MasterCard \_\_\_\_\_  
Card number Expiration

Return Shipping Method:

- UPS:  Ground  3 Day Select  Next Day Air  ND Air Saver  2-Day Air  
 Federal Express:  Ground  Express Saver  P-1  Standard  2-Day Air  
 FedEx Account number: \_\_\_\_\_

Would you like ENMET to insure the return shipment?

No  Yes Insurance Amount: \$ \_\_\_\_\_

