

**ENMET Corporation**  
**PO Box 979**  
**Ann Arbor, MI 48106-0979**

**SDS – 97D**  
**Sensor Transmitter**  
**Manual**

**Manual Part Number**  
**80003-034**  
**MCN-443, 01/21/11**

## Table of Contents

<b>1.0 INTRODUCTION .....</b>	<b>1</b>
1.1 Unpack .....	1
1.2 Check Order .....	1
1.3 Serial Numbers .....	1
<b>2.0 SENSOR / TRANSMITTER .....</b>	<b>2</b>
2.1 Features .....	2
2.2 Installation .....	3
2.2.1 <i>Sensor/Transmitter without ISB</i> .....	3
2.2.2 <i>Sensor/Transmitter with ISB</i> .....	4
2.3 Calibration .....	6
2.3.1 <i>Automatic Zeroing</i> .....	7
2.3.2 <i>Automatic Calibration</i> .....	7
<b>3.0 PROGRAMMER.....</b>	<b>8</b>
<b>4.0 SENSOR REPLACEMENT.....</b>	<b>8</b>
<b>5.0 WARRANTY .....</b>	<b>9</b>

## List of Illustrations

<b>FIGURE A: SDS – 97D SENSOR/TRANSMITTER</b>	<b>2</b>
<b>TABLE 1: WIRING WITHOUT ISB</b>	<b>3</b>
<b>FIGURE B: DIRECT WIRING TO CONTROL</b>	<b>3</b>
<b>TABLE 2: WIRING AT S/T</b>	<b>4</b>
<b>FIGURE C: WIRING TO ISB</b>	<b>4</b>
<b>TABLE 3: WIRING AT ISB</b>	<b>5</b>
<b>FIGURE D: WIRING TO ISB IN CONTROL</b>	<b>5</b>
<b>TABLE 4: STIPULATED CALIBRATION GASES FOR DIGITAL SENSOR/TRANSMITTERS</b>	<b>6</b>
<b>FIGURE E: CALIBRATION WITH GAS</b>	<b>7</b>
<b>FIGURE F: SDS – 97D SENSOR/TRANSMITTER WITH TURRET AND SENSOR REMOVED</b>	<b>8</b>

## 1.0 Introduction

- ◆ Each sensor/transmitter consists of an electrochemical gas detection sensor combined with digital circuitry to detect a particular toxic gas, or to detect oxygen concentrations.
- ◆ Each sensor/ transmitter is equipped with an LCD display to indicate the level of concentration of gas or oxygen in the vicinity of the sensor/transmitter.
- ◆ Each sensor/transmitter is equipped with a pushbutton switch for easy automatic zeroing and calibration with bottled gas.
- ◆ Each sensor/transmitter is in a painted aluminum enclosure provided with gaskets designed to furnish NEMA-4 protection.
- ◆ Sensor/transmitters are three wire devices, with two of the wires forming a 4-20 mA loop.
- ◆ Some sensor/transmitters are equipped with a communications circuit and connector which, when used in conjunction with a programmer, facilitates the changing of a sensor without recalibration.

**NOTE:** *All specifications stated in this manual may change without notice.*

### 1.1 Unpack

Unpack the **SDS – 97D** and examine it for shipping damage. If such damage is observed, notify both **ENMET** customer service personnel and the commercial carrier involved immediately.

#### Regarding Damaged Shipments

**NOTE: It is your responsibility to follow these instructions. If they are not followed, the carrier will not honor any claims for damage.**

- This shipment was carefully inspected, verified and properly packaged at our company and delivered to the carrier in good condition.
- When it was picked up by the carrier at **ENMET**, it legally became your company's property.
- If your shipment arrives damaged:
  - Keep the items, packing material, and carton "As Is." Within 5 days of receipt, notify the carrier's local office and request immediate inspection of the carton and the contents.
  - After the inspection and after you have received written acknowledgment of the damage from the carrier, contact **ENMET** Customer Service for return authorization and further instructions. Have your Purchase Order and Sales Order numbers available.
- **ENMET** either repairs or replaces damaged equipment and invoices the carrier to the extent of the liability coverage, usually \$100.00. Repair or replacement charges above that value are your company's responsibility.
- The shipping company may offer optional insurance coverage. **ENMET** only insures shipments with the shipping company when asked to do so in writing by our customer. If you need your shipments insured, please forward a written request to **ENMET** Customer Service.

#### Regarding Shortages

If there are any shortages or questions regarding this shipment, please notify **ENMET** Customer Service within 5 days of receipt at the following address:

**ENMET Corporation**  
680 Fairfield Court  
Ann Arbor, MI 48108  
734-761-1270 734-761-3220 Fax

### 1.2 Check Order

Check the contents of the shipment against the purchase order. Verify that the **SDS – 97D** is received as ordered. Each **SDS – 97D** is labeled with its target gas.] If there are accessories on the order, ascertain that they are present. Check the contents of calibration kits. Notify **ENMET** customer service personnel of any discrepancy immediately.

### 1.3 Serial Numbers

Each **SDS – 97D** is serialized. These numbers are on tags on the equipment and are on record in an **ENMET** database.

## 2.0 Sensor / Transmitter

### 2.1 Features

See figure A for location of features for both styles of enclosure.

Feature	Function
Display	LCD, indicated the level of gas or oxygen detected by sensor
Pushbutton Switch	For automatic zeroing and calibration, see section 2.3
Communications Connector	For programming with programmer, see section 3
Sensor	For sensing gas or oxygen, see table 4 for sensor types

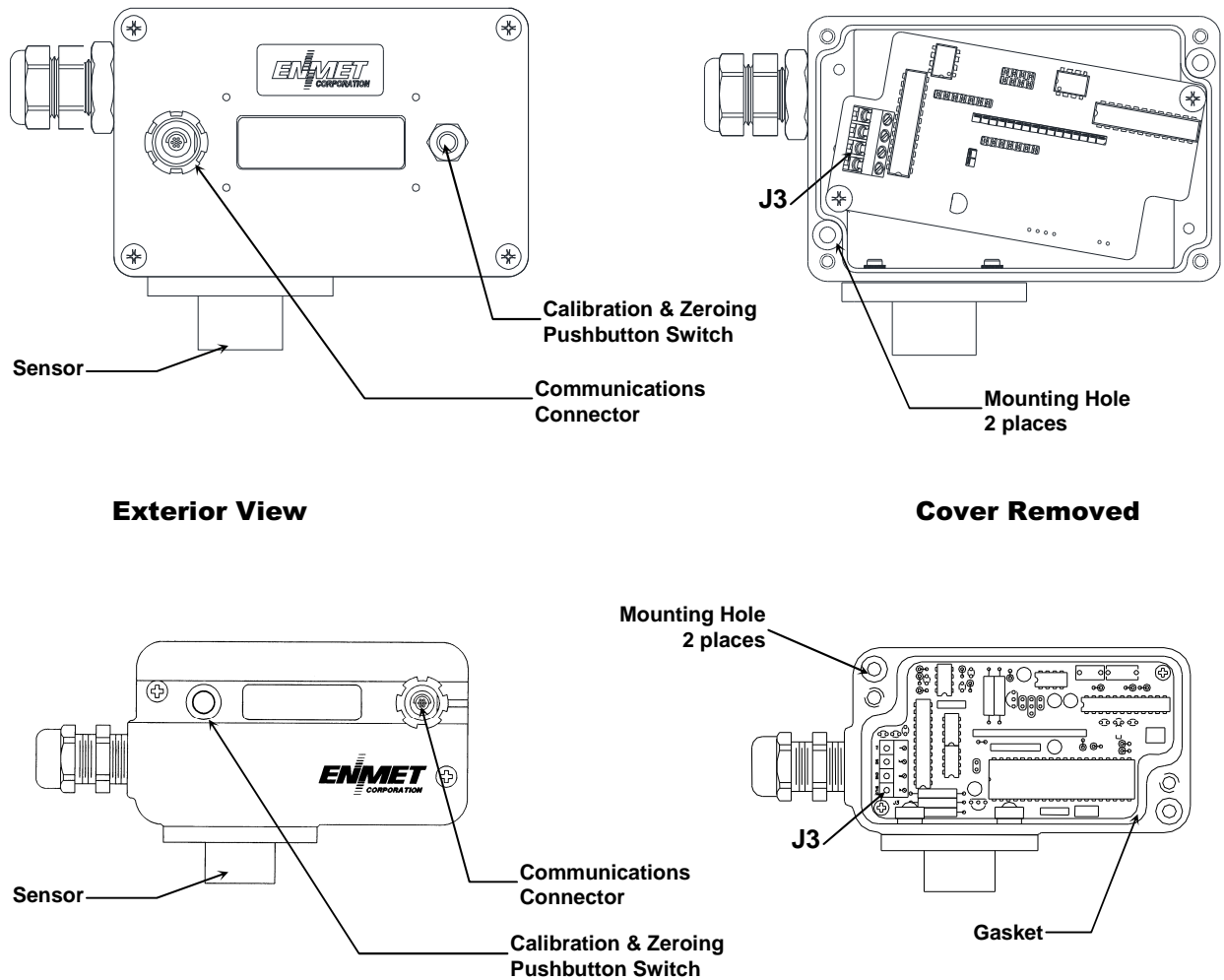

Figure A: SDS – 97D Sensor/Transmitter

## 2.2 Installation

- The interior of a sensor/transmitter with the cover removed is shown in the accompanying **Figure A**, for reference during these operations.
- Remove the cover of the sensor/transmitter by removing the two black cover screws.
- Mount the sensor/transmitter to an appropriate stable vertical surface with the sensor facing downward.

**CAUTION:** Since the sensor/transmitter detects gas only at the sensor location, pay attention to the possible sources of gas, the density of the gas, locations where the gas may be confined and locations where the gas may damage or injure property or personnel, when choosing locations of sensor/transmitters.

- Mount the sensor/transmitter using the two mounting holes in the corners of the enclosure. For maximum RFI protection the enclosure should be grounded to earth ground, either by means of the mounting screws, a conductive conduit, or a wire connected to earth ground.
- The interface terminal strip J3 is located at the left edge of the internal circuit board. Wires enter through the port in the left wall of the enclosure, that is supplied with a watertight strain relief. Wiring may be with good quality three conductor shielded cable or with three insulated wires in metallic conduit. When the watertight strain relief is removed, the hole at the entry point is threaded 3/8 NPT female; use appropriate watertight conduit fittings.

### 2.2.1 Sensor/Transmitter without ISB

Wiring without Intrinsic Safety Barriers to the following points shown in Table 1 and Figure B:

**Table 1: Wiring Without ISB**

Position	Function
J3-1	V+, the power supply
J3-2	signal, the positive side of the loop
J3-3	ground, the negative side of the loop
J3-4	shield, earth ground

Maximum resistance of the power supply wire is 300 ohms when 24 VDC is supplied at the control, and the maximum load resistance of the signal loop is 300 ohms. A very small current flows in the negative signal wire. To avoid current loops in the earth ground circuit, connect one end, only, of the shield or conduit to earth ground.

Connect the other ends of the three wires to the appropriate terminals of the control or computer used to monitor the 4-20 mA sensor/transmitter signal, and the power supply. A power supply must be capable of providing 10 to 24 VDC at the sensor/transmitter. Maximum current draw is 45 mA.

Allow the sensor/transmitter to stabilize for 3 to 24 hours.

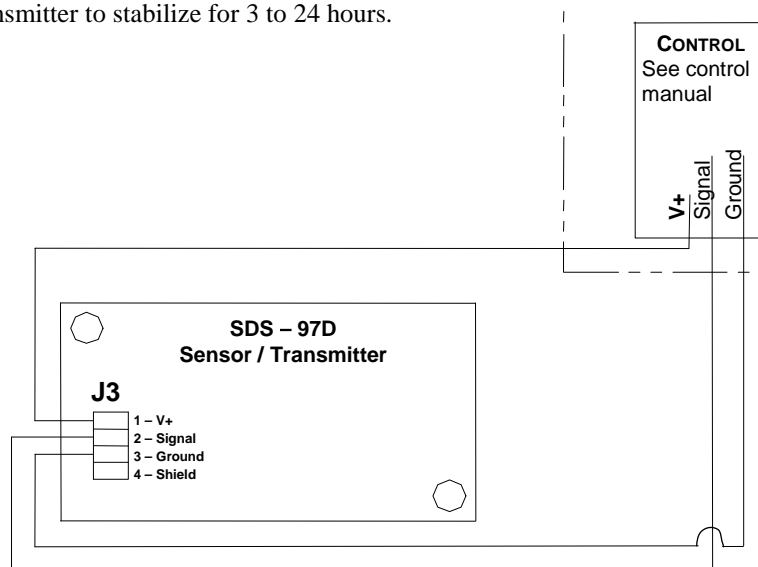

**Figure B: Direct Wiring to CONTROL**

**2.2.2 Sensor/Transmitter with ISB**

Installation with a recommended Intrinsic Safety Barrier properly connected and grounded renders the sensor/transmitter nonincendive as defined by the National Electrical Code. An MTL 787S+ barrier is recommended connected as shown in **Figure C**. Connections at the sensor/transmitter are shown in Table 2 as follows:

**Table 2: Wiring at S/T**

Position	Function
J3-1	V+, the power supply
J3-2	signal, the positive side of the loop
J3-3	ground, the negative side of the loop
J3-4	shield, only if the sensor/transmitter enclosure is not grounded

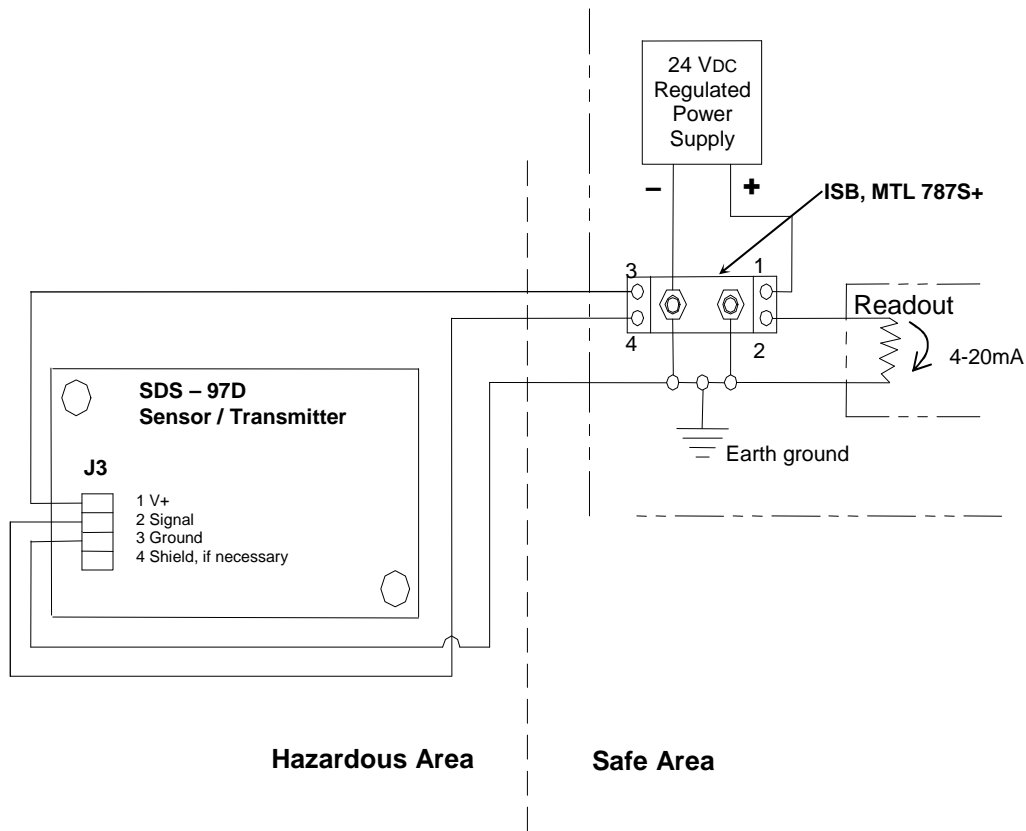

**Figure C: Wiring to ISB**

When the sensor/transmitter is mounted and wired, assure that the cover gasket is in place, replace the cover, and secure it with the two cover screws.

Allow the sensor/transmitter to stabilize for 3 to 24 hours.

If the sensor/transmitter enclosure is grounded, connect the shield at the control.

The terminals on the barrier are clearly numbered, and a schematic of the barrier is on a label on the barrier housing. At the barrier, the connections are as shown in Table 3 and Figure D:

**Table 3: Wiring at ISB**

Position	Function
1	V+, power supply, safe side
2	signal, the positive side of the loop, safe side
3	V+, power supply, hazardous side
4	signal, the positive side of the loop, hazardous side

The negative side of the loop (from J3-3 at the sensor/transmitter), the negative side of the readout device, and the negative side of the 24 VDC power supply are all connected to earth ground at the barrier. When working in a hazardous area, even if it has been temporarily declassified, it is good practice to connect the negative side of the loop to earth ground first, and, if disconnecting a sensor/transmitter, disconnect the same wire last. The two ground points on the barrier must be securely connected to earth ground with a connection that cannot be interrupted by separating a connector or pulling the plug of a line cord.

A regulated 24 VDC power supply must be used to provide the V+ power to the sensor/transmitter. Supplying over 26 VDC blows the fuses in the barrier, and the barrier must be replaced.

The maximum resistance of the power supply wire is 125 ohms when 24 VDC is supplied through the barrier. The maximum combined resistance of the positive loop wire and the readout device is 340 ohms. Very little current flows in the negative loop wire.

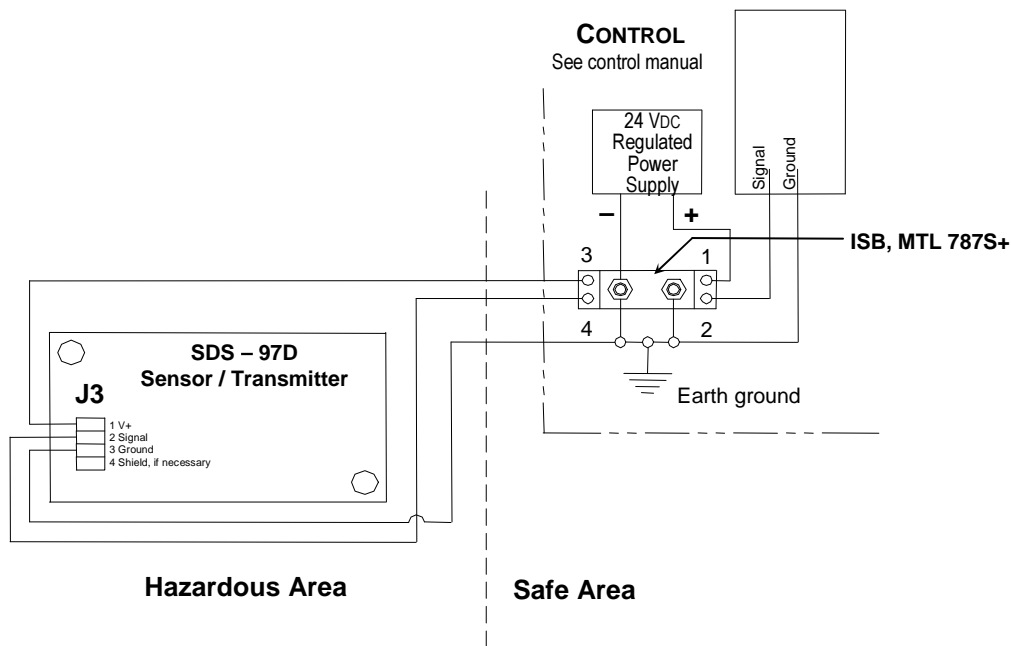

**Figure D: Wiring to ISB in CONTROL**

When the sensor/transmitter is mounted and wired, assure that the cover gasket is in place, replace the cover, and secure it with the two cover screws.

Allow the sensor/transmitter to stabilize for 3 to 24 hours.

## 2.3 Calibration

**CAUTION:** Sensor/transmitters must be calibrated with the stipulated calibration gas. Although safeguards are provided, it is possible to miscalibrate a sensor/transmitter by using the incorrect gas.

Calibration is the process of aligning the pre set instrument electronics to the installed sensors, making the instrument read accurately. It consists of a zero reading which tells the instrument what it should read in uncontaminated (clean) air, and a span reading that tells the instrument what it should read in the presence of its target gas. Calibration, including the zero and span adjustments should be performed on a quarterly basis.

Sensor/transmitters are supplied with a pushbutton switch, located on the left side of the front surface. Never push this switch unless zero or span gas is being applied to the sensor (see caution). This switch facilitates automatic zeroing and automatic calibration with appropriate gas. The parameters described; stipulated calibration gas, response to calibration gas and the **ENMET** part number for a cylinder of calibration gas are given for various sensor types in Table 4.

**Table 4: Stipulated Calibration Gases for Digital Sensor/Transmitters**

S/T for Gas	Calibration Gas	Response	Cal Gas P/N
Ammonia	50ppm NH3	50 ppm	03318-050
Arsine	0.5 ppm PH3	0.5 ppm	03305-005
Boron Trichloride	10 ppm HCL	10 ppm	03302-010
Carbon Monoxide	100 ppm CO	100 ppm	03219-100
Chlorine	5 ppm CL2	5 ppm	03331-005
Chlorine Dioxide	Consult <b>ENMET</b>		
Chlorine Trifluoride	Consult <b>ENMET</b>		
Dichlorosilane	10 ppm HCL	3 ppm	03302-010
Ethylene Oxide	5 ppm ETO	5 ppm	03332-005
Fluorine	Consult <b>ENMET</b>		
Hydrogen	800 ppm H2	800 ppm	03227-800
Hydrogen Bromide	5 ppm HCL	25 ppm	03302-005
Hydrogen Chloride	10 ppm HCL	10 ppm	03302-010
Hydrogen Cyanide	10 ppm HCN	10 ppm	03303-010
Hydrogen Fluoride	5 ppm CL2	3 ppm	03331-005
Hydrogen Sulfide	20 ppm H2S	20 ppm	03314-020
Nitrogen Dioxide	5 ppm NO2	5 ppm	03333-005
Nitric Oxide	25 ppm NO	25 ppm	03334-025
Oxygen *see note 2	20.9 % O2	20.9 %	03296-209
Ozone	0.3 ppm O3	0.3 ppm	Use Ozone generator
Phosgene	Consult <b>ENMET</b>		
Phosphine	0.5 ppm PH3	0.5 ppm	03205-005
Silane	5 ppm SiH4	5 ppm	03306-005
Silicon Tetrachloride	5 ppm HCL	25 ppm	03302-005
Sulfur Dioxide	10 ppm SO2	10 ppm	03315-010

**NOTE 1:** All specifications stated in this manual may change without notice.

**NOTE 2:** \* Oxygen S/T with a 0 – 30% range are zero set at the factory. 20.9% by volume O2/78.1% by volume N2 is the calibration gas. If zeroing of an Oxygen S/T should be needed 100% by volume N2 (0% by volume O2) is the zero gas.  
Toxic S/T 20.9% by volume/78.1% by volume N2 may be used for (clean air) zero gas, see section 2.3.1 automatic zeroing.

### 2.3.1 Automatic Zeroing

**OXYGEN S/T:** Oxygen S/T, 0 – 30% by volume, do not require the automatic zeroing step, proceed to section 2.3.2 automatic calibration.

**TOXIC S/T:** If the air around the sensor/transmitter contains significant levels of the target gas or interference gases, the sensor must be exposed to a source of fresh, clean air to perform an automatic zeroing procedure. Kits are available from **ENMET** Corporation that includes a cylinder of 20.9% oxygen, free of contaminants. The recommended flow rate of air from a cylinder is 0.5 liters per minute.

Expose the sensor to fresh clean air for at least 30 seconds. Press and release the **Calibration & Zeroing Pushbutton Switch**. After the switch is released, if the signal from the sensor is within the established Zero (clean) range, the sensor/transmitter display is forced to zero. If the sensor reading is too high or too low, zeroing will not take place.

**NOTE:** Under certain conditions, the display may be off 1 display unit.

If the sensor/transmitter does not read zero and continues to read more than several display units above zero, expose the sensor to clean air from a cylinder of 20.9% oxygen for 2 minutes. After 2 minutes, press and release the **Calibration & Zeroing Pushbutton Switch** again. If the display still does not zero, the sensor may need to be replaced.

### 2.3.2 Automatic Calibration

**ENMET** Corporation makes available a calibration kit that contains the stipulated calibration gas and a calibration adapter.

With reactive gases it is imperative that the proper regulator, tubing and calibration cover be used. Failure to do so, may cause inaccurate and/or failed calibrations. Contact your local distributor or **ENMET** for more information.

See Table 4 for calibration gas values and replacement cylinder part numbers.

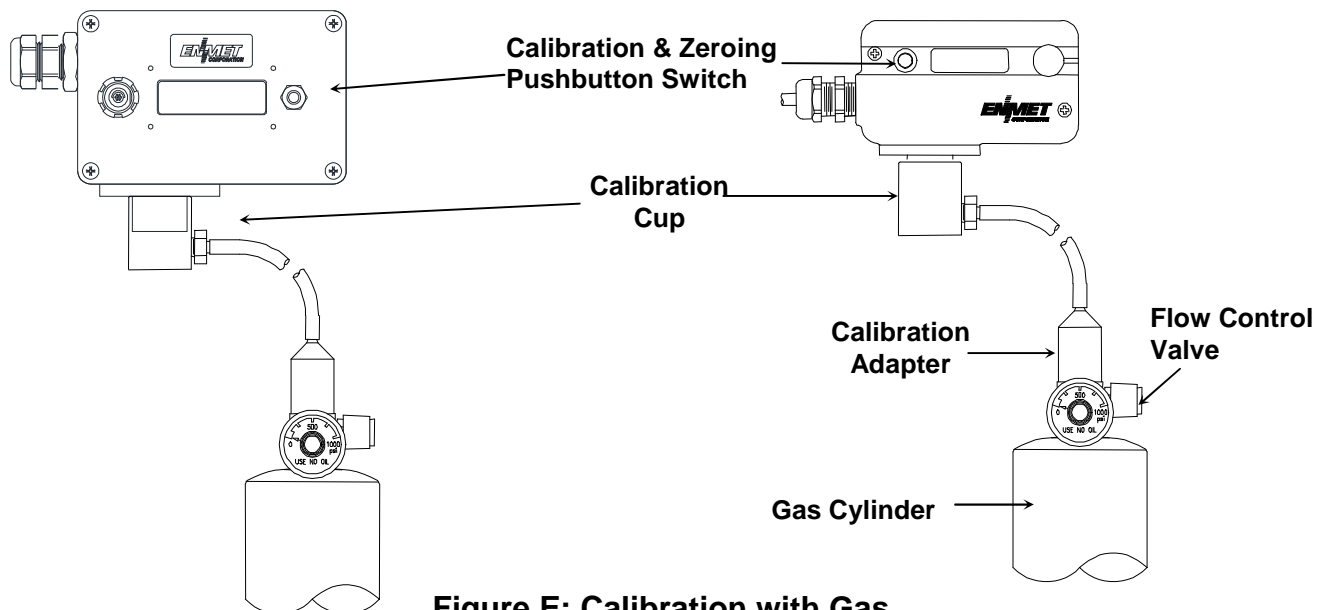

**Figure E: Calibration with Gas**

Screw the regulator valve of the calibration adapter onto the calibration gas cylinder, and open the flow control valve. Put the cup over the sensor. See Figure E. After 1-3 minutes, when the display stops changing, press the calibration switch.

If the sensor output is within the calibration range, the display changes to the value of the contents of the calibration gas.

*Example* if calibrating with 50 PPM CO, the display changes to “0050”.

**NOTE:** Under certain conditions, the display may be off  $\pm 1$  display unit, Hydrogen may be off  $\pm 20$  ppm.

**WARNING:** If at this point the display does not change, calibration has not been accomplished. Check the following:

- ◆ Be sure that the proper calibration adapter is being used. Reactive gases can be absorbed by standard tubing. Special non-reactive tubing should be used for reactive gases. **ENMET** calibration kits are supplied with appropriate tubing for the gas in the kit.
- ◆ Be sure that the gas is not outdated. The shelf life or manufacture date is on the gas cylinder label.
- ◆ If sufficient fresh calibration gas is being used, try the calibration again. If the same result is obtained, the most probable cause is a sensor with low output. Such a sensor is nearing the end of its useful life. Install a new sensor per Section 4.0, and recalibrate.

### 3.0 Programmer

If the SDS-97D sensor/transmitter is supplied with the communication port option, it has the capability to interface with a remote programming device. The SDS-97D Programmer is supplied with its own manual detailing its operation.

### 4.0 Sensor Replacement

Sensors need to be replaced when they no longer respond properly to calibration gas.

Sensor lifetimes vary. To replace a sensor, remove the sensor turret on the bottom of the transmitter. See figure F. Gently remove the sensor from the transmitter. Remove the replacement sensor from its protective case.

**NOTE:** Remove any shorting wire or clips attached to the new sensor. The shorting wire may have the appearance of a small spring that is connecting two pins on bottom of the sensor.

Invert the sensor and gently insert it into the sockets on bottom of the transmitter assembly. Re-attach the turret.

Allow the sensor stabilize in the transmitter for 3 to 24 hours and then

Calibrate the new sensor in accordance with Section 2.3.

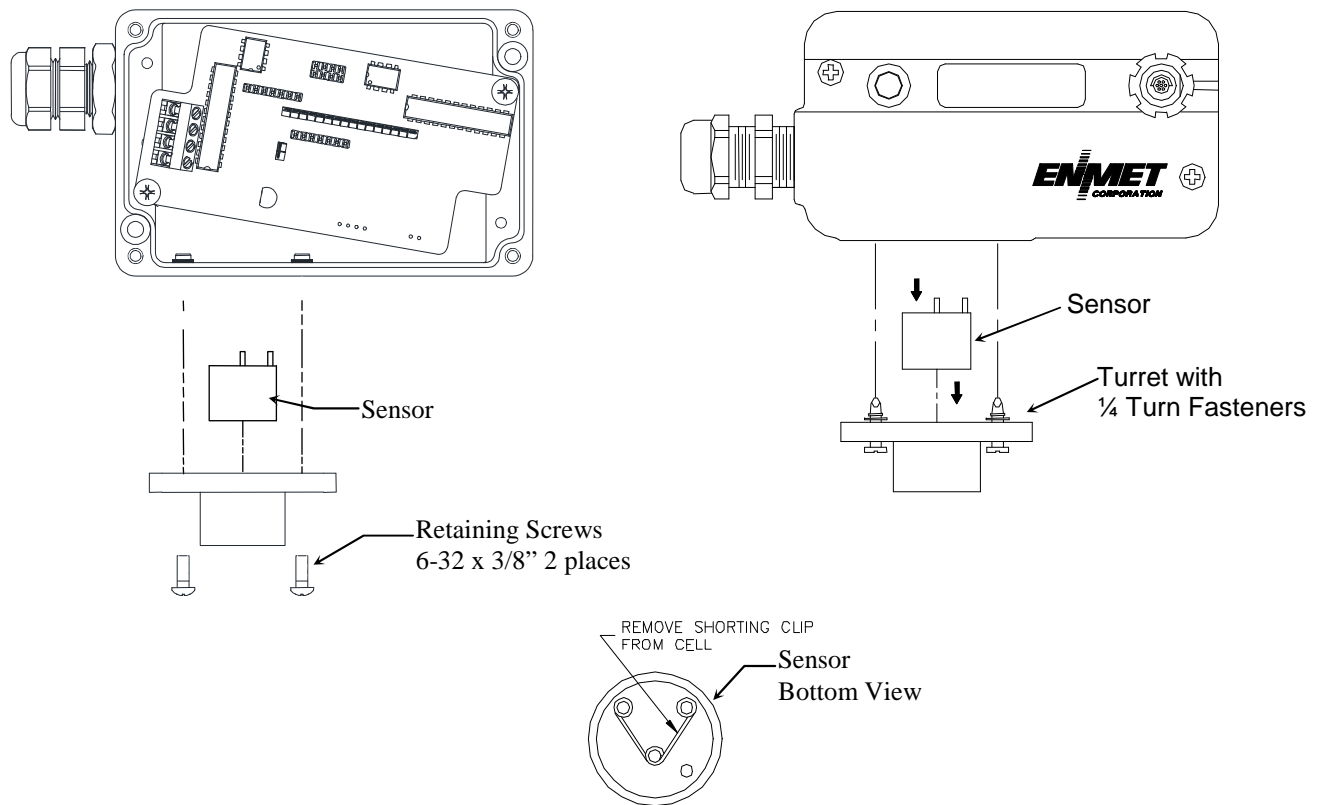

**Figure F: SDS – 97D Sensor/Transmitter with Turret and Sensor Removed**

## 5.0 Warranty

**ENMET** warrants new instruments to be free from defects in workmanship and material under normal use for a period of one year from date of shipment from **ENMET**. The warranty covers both parts and labor excluding instrument calibration and expendable parts such as calibration gas, filters, batteries, etc... Equipment believed to be defective should be returned to **ENMET** within the warranty period (transportation prepaid) for inspection. If the evaluation by **ENMET** confirms that the product is defective, it will be repaired or replaced at no charge, within the stated limitations, and returned prepaid to any location in the United States by the most economical means, e.g. Surface UPS/FedEx Ground. If an expedient means of transportation is requested during the warranty period, the customer is responsible for the difference between the most economical means and the expedient mode. **ENMET** shall not be liable for any loss or damage caused by the improper use of the product. The purchaser indemnifies and saves harmless the company with respect to any loss or damages that may arise through the use by the purchaser or others of this equipment.

This warranty is expressly given in lieu of all other warranties, either expressed or implied, including that of merchantability, and all other obligations or liabilities of **ENMET**, which may arise in connection with this equipment. **ENMET** neither assumes nor authorizes any representative or other person to assume for it any obligation or liability other than that which is set forth herein.

NOTE: When returning an instrument to the factory for service:

- Be sure to include paperwork.
- A purchase order, return address and telephone number will assist in the expedient repair and return of your unit.
- Include any specific instructions.
- For warranty service, include date of purchase
- If you require an estimate, please contact **ENMET**.

There are Return for Repair Instructions and Form on the last pages of this manual. This Form can be copied or used as needed.

Manual Part Number

80003-034

January 1999

MCN-232, 03/30/00

MCN-239, 01/25/01

MCN-272, 03/07/02

MCN-320, 08/18/04

MCN-387, 10/23/07

MCN-443, 01/21/11

### Notes:



PO Box 979  
680 Fairfield Court  
Ann Arbor, Michigan 48106-0979  
734.761.1270 Fax 734.761.3220

# Returning an Instrument for Repair

**ENMET** instruments may be returned to the factory or any one of our Field Service Centers for regular repair service or calibration. The **ENMET** Repair Department and Field Service Centers also perform warranty service work.

When returning an instrument to the factory or service center for service, paperwork must be included which contains the following information:

- A purchase order number or reference number.
- A contact name with return address, telephone and fax numbers
- Specific instructions regarding desired service or description of the problems being encountered.
- Date of original purchase and copy of packing slip or invoice for warranty consideration.
- If a price estimate is required, please note it accordingly *and be sure to include a fax number.*

Providing the above information assists in the expedient repair and return of your unit.

**Failure to provide this information can result in processing delays.**

**ENMET** charges a one hour minimum billing for all approved repairs with additional time billed to the closest tenth of an hour. All instruments sent to **ENMET** are subject to a minimum evaluation fee, even if returned unrepaired. Unclaimed instruments that **ENMET** has received without appropriate paperwork or attempts to advise repair costs that have been unanswered, after a period of 60 days, may be disposed of or returned unrepaired COD with the evaluation fee.

Service centers may have different rates or terms. Be sure to contact them for this information.

**Repaired instruments are returned by UPS/FedEx Ground and are not insured unless otherwise specified. If expedited shipping methods or insurance is required, it must be stated in your paperwork.**

**Note:** Warranty of customer installed components.

If a component is purchased and installed in the field, and fails within the warranty term, it can be returned to **ENMET** and will be replaced, free of charge, per **ENMET**'s returned goods procedure.

If the entire instrument is returned to **ENMET** Corporation with the defective item installed, the item will be replaced at no cost, but the instrument will be subject to labor charges at half of the standard rate.



# Repair Return Form

Mailing Address:  
ENMET Corporation  
PO Box 979  
Ann Arbor, Michigan 48106

Shipping Address:  
ENMET Corporation  
Attn: Repair Department  
680 Fairfield Court  
Ann Arbor, Michigan 48108

Phone Number: 734.761.1270  
FAX Number: 734.761.3220

Your Mailing Address:

Your Shipping Address:

\_\_\_\_\_  
\_\_\_\_\_  
\_\_\_\_\_  
\_\_\_\_\_

\_\_\_\_\_  
\_\_\_\_\_  
\_\_\_\_\_  
\_\_\_\_\_

Contact Name: \_\_\_\_\_ Your Phone: \_\_\_\_\_  
Your PO/Reference Number: \_\_\_\_\_ Your FAX: \_\_\_\_\_

Payment Terms:  COD

(Check one)  **VISA / MasterCard** \_\_\_\_\_  
Card number Expiration Card Code

**American Express** \_\_\_\_\_  
Card number Expiration Card Code

**Name as it appears on the credit card** \_\_\_\_\_

Return Shipping Method:

UPS:  Ground  3 Day Select  Next Day Air  ND Air Saver  2-Day Air  
 UPS Account number: \_\_\_\_\_

Federal Express:  Ground  Express Saver  P-1  Standard  2-Day Air  
 FedEx Account number: \_\_\_\_\_

Would you like **ENMET** to insure the return shipment?

No  Yes Insurance Amount: \$ \_\_\_\_\_