

**ENMET Corporation**  
**PO Box 979**  
**Ann Arbor, MI 48106-0979**

**ISA-60M**  
**with MRI-5175**  
**OPERATION AND MAINTENANCE**  
**MANUAL**

**Manual Part Number**  
**80003-500**  
**MCN-397, 02/04/08**

# Table of Contents

1.0 Introduction .....	1
1.1 IEC 60601-1 Classifications .....	1
1.2 Unpack.....	1
1.3 Check Order .....	1
1.4 Serial Numbers.....	1
2.0 Instrument Features .....	2
2.1 ISA-60M Exterior Features.....	2
2.2 Display ISA-60M Front Panel Features.....	2
2.3 MRI-5175 Exterior Features .....	2
2.3 Circuit Board Features.....	4
3.0 Installation .....	5
3.1 Mounting of Instrument .....	5
3.2 Mounting MRI-5175 Remote Sensor .....	5
3.3 Power Supply .....	6
3.4 Wiring ISA-60M to MRI-5175 .....	6
3.4.1 Outputs.....	6
3.4.2 Relay Contacts.....	7
3.4.3 4-20mA Outputs .....	8
3.4.4 Digital Outputs .....	8
3.5 Initial Calibration .....	8
4.0 Operation .....	9
4.1 Normal Operation Condition.....	9
4.2 Alarm Set Points .....	9
4.3 Alarm Latching .....	9
4.4 Audio Defeat .....	9
4.5 Display.....	10
4.6 Operational Menu.....	10
4.7 Fault Indications.....	10
5.0 Maintenance.....	11
5.1 Cleaning Instructions.....	11
5.2 Maintenance Menu ISA-60M.....	11
5.2.1 Set 4 –20mA Transmitter Scale .....	12
5.2.2 Set Alarm Points.....	13
5.2.3 Set Alarm “Delay On” .....	15
5.2.4 Relay Configuration.....	15
5.2.5 Failsafe Configuration.....	15
5.2.6 Set New Password .....	17
5.2.7 Exit Maintenance Menu .....	17
5.3 MRI-5175 Sensor Transmitter .....	17
6.0 Maintenance MRI-5175.....	18
6.1 MRI-5175 Calibration .....	18
6.2 Sensor Replacement .....	19
7.0 Technical Data and Specifications .....	20
8.0 Replacement Part Numbers.....	21
9.0 WARRANTY .....	21

## List of Figures

Figure 1: ISA-60M & MRI-5175 External Features .....	3
Figure 2: ISA-60M Interior Features.....	4
Figure 3: ISA-60M Mounting Dimensions.....	5
Figure 4: MRI-5175 REMOTE SENSOR Mounting Dimensions.....	5
Figure 5: ISA-60M Relay, Input and Output Terminals.....	6
Figure 5A: MRI-5175 Relay, Input and Output Terminals.....	7
Figure 6: ISA-60M Operational Display .....	9
Figure 7: ISA-60M Operation Menu Flow Chart.....	10
Figure 8: ISA-60M Maintenance Menu Flow Chart .....	11
Figure 9: Calibration MRI-5175 .....	19
Figure 10: MRI-5175 Sensor Replacement .....	19

## List of Tables

Table 1: Wiring ISA-60M to MRI-5175.....	7
Table 2 : Relay Failsafe Settings.....	7
Table 3: Set up values .....	12
Table 4: Default Relay Links.....	15
Table 5: Fault LED Code Sequence .....	18

### Reference Information:

NOTE: [important information about use of instrument]

**CAUTION:** [affects equipment – if not followed may cause damage to instrument, sensor etc...]

**WARNING:** [affects personnel safety – if not followed may cause bodily injury or death.]



Attention / Warning



Earth Ground

## 1.0 Introduction

The **ISA-60M w/MRI-5175** is an ambient air monitoring system that measures oxygen concentrations in magnetic resonance imaging environments. The **ISA-60M** control panel is capable of monitoring from 1 to 3 **MRI-5175** remote sensors. Some features of the monitoring system are as follows:

- continuous monitoring of the sample air
- continuous LCD display oxygen concentrations, at **ISA-60M**
- menu driven operational and maintenance controls
- menu driven calibration procedure
- audio and visual alarms indicate unsafe conditions
- alarm relay contacts available on terminals
- a fault relay and visual fault alarm
- alarm acknowledgement capability including audio defeat
- mA output for each channel

**NOTE:** *All specifications stated in this manual may change without notice.*

### 1.1 IEC 60601-1 Classifications

Type of protection against electrical shock: Class 1.

Degree of protection against electrical shock: No Applied Parts

- Equipment not suitable for use in presence of flammable anesthetic mixture with air or with oxygen or nitrous oxide.
- Mains power quality should be that of a typical commercial or hospital environment.
- Power frequency magnetic fields should be at levels characteristic of a typical location in a commercial or hospital environment.

### 1.2 Unpack

Unpack the **ISA-60M** and examine it for shipping damage. If such damage is observed, notify both **ENMET** customer service personnel and the commercial carrier involved immediately.

#### Regarding Damaged Shipments

**NOTE: It is your responsibility to follow these instructions. If they are not followed, the carrier will not honor any claims for damage.**

- This shipment was carefully inspected, verified and properly packaged at our company and delivered to the carrier in good condition.
- When it was picked up by the carrier at **ENMET**, it legally became your company's property.
- If your shipment arrives damaged:
  - Keep the items, packing material, and carton "As Is." Within 5 days of receipt, notify the carrier's local office and request immediate inspection of the carton and the contents.
  - After the inspection and after you have received written acknowledgment of the damage from the carrier, contact **ENMET** Customer Service for return authorization and further instructions. Have your Purchase Order and Sales Order numbers available.
- ENMET** either repairs or replaces damaged equipment and invoices the carrier to the extent of the liability coverage, usually \$100.00. Repair or replacement charges above that value are your company's responsibility.
- The shipping company may offer optional insurance coverage. **ENMET** only insures shipments with the shipping company when asked to do so in writing by our customer. If you need your shipments insured, please forward a written request to **ENMET** Customer Service.

#### Regarding Shortages

If there are any shortages or questions regarding this shipment, please notify **ENMET** Customer Service within 5 days of receipt at the following address:

**ENMET Corporation**  
**680 Fairfield Court**  
**Ann Arbor, MI 48108**  
**734-761-1270    734-761-3220 Fax**

### 1.3 Check Order

Check the contents of the shipment against the purchase order. Verify that the **ISA-60M** is received as ordered. If there are accessories on the order, ascertain that they are present. Check the contents of calibration kits. Notify **ENMET** customer service personnel of any discrepancy immediately.

### 1.4 Serial Numbers

Each **ISA-60M** and **MRI-5175** is serialized. These numbers are on tags on the equipment and are on record in an **ENMET** database.

## 2.0 Instrument Features



### 2.1 ISA-60M Exterior Features

The exterior of the instrument is shown in **Figure 1**. The exterior features are as follows:

Feature	Description
<b>Enclosure</b>	Engineered thermoplastic, approximately 11x9x6, with a clear hinged front cover.
<b>Strain Relief</b>	Entrance for wiring to Remote Sensor
<b>Input Port</b>	The entrance for the calibration gas. The quick release fitting mates with one on the calibration adapter.
<b>Audio Alarm</b>	A loud horn activated by certain alarm conditions.
<b>Mounting Flanges</b>	Flanges with holes for mounting the enclosure to a vertical surface.



### 2.2 Display ISA-60M Front Panel Features

The display panel, shown in **Figure 1**, is viewed through the clear front cover of the enclosure, and is accessed by opening the cover. Features are as follows:

Feature	Description
<b>Display</b>	2 line, 16 character per line, LCD with backlight. The numerical values of gas concentrations, and other information are displayed.
<b>Visual Alarms &amp; Indicators</b>	On either sides of the display: A red alarm LED for each sensor transmitter installed to the instrument, Alarm 1. The top center: A red alarm LED for all sensor transmitters, Alarm 2. Near the center of the panel: A green power indicator LED A red fault alarm LED
<b>Pushbutton Switches</b>	There are three of these, located near the center of the panel; they are yellow rectangular membrane switches. They are:
• <b>OPTION Switch</b>	The top left switch. 
• <b>SELECT Switch</b>	Directly to the right of the <b>OPTION</b> switch. 
• <b>AUDIO DEFEAT / ALARM ACKNOWLEDGE Switch</b>	Directly below the <b>OPTION</b> switch. 

### 2.3 MRI-5175 Exterior Features

The exterior and panel of the sensor/transmitter is shown in **Figure 1**. The **MRI-5175** features are as follows:

Feature	Description
<b>Enclosure</b>	Fiberglass-reinforced polyester approximately 5" square, with non-magnetic hardware.
<b>Strain Relief</b>	Entrance for wiring to <b>ISA-60M</b> control unit
<b>Mounting Flanges</b>	Flanges with holes for mounting the enclosure to a vertical surface.
<b>MENU Switch</b>	The left most pushbutton switch 
<b>SELECT Switch</b>	The right most pushbutton switch 
<b>Power/Fault LED</b>	Red/Green LED, Green indicating power on and red indicating a fault condition
<b>Visual Alarm LED</b>	3 Red LED, Triggered at level of alarm
<b>Sensor</b>	Long life electrochemical oxygen sensor
<b>Audio Alarm (Optional)</b>	A loud horn activated by certain alarm conditions.

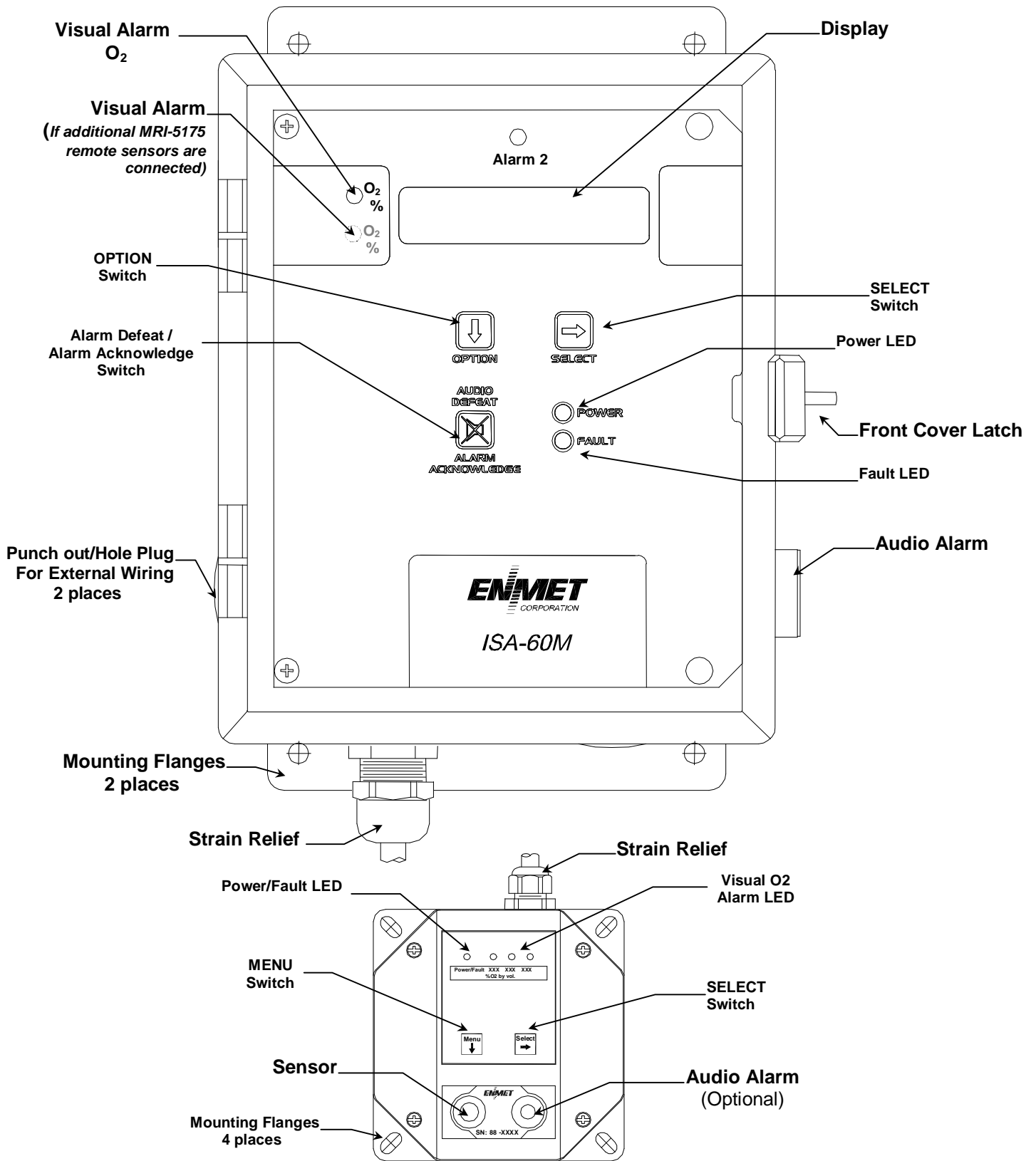

Figure 1: ISA-60M & MRI-5175 External Features

### 2.3 Circuit Board Features

The Display Panel is hinged on the left and is released by unscrewing the 2 philips screws located in the top and bottom right corners. After releasing the panel, it is swung to the left, exposing the interior of the enclosure. The Circuit Board is mounted on a plate at the back surface of the enclosure interior. Features are shown in **Figure 2**.

Feature	Description
Relay Terminals	This group of terminals is located at the left side of the Circuit Board. For the contacts for each of four alarm relays, and for the contacts of a fault relay.
Output Terminals	There are two for each of the 4-20 mA outputs.

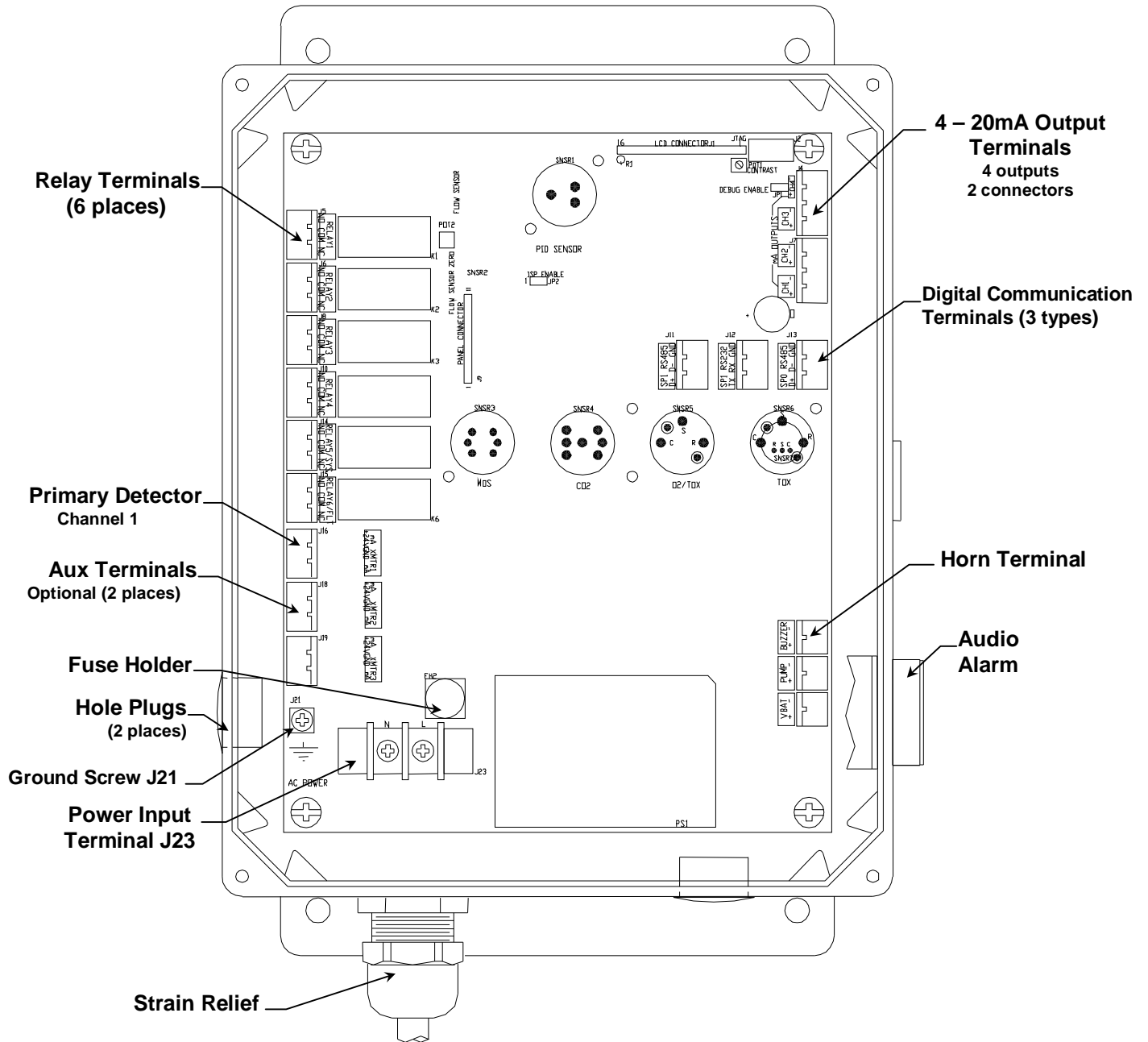

Figure 2: ISA-60M Interior Features

### 3.0 Installation

#### 3.1 Mounting of Instrument

Mount the **ISA-60M** instrument on an appropriate vertical surface using the mounting flanges provided. Avoid areas with excessive vibration or temperature extremes. The holes in the flanges are 0.31 inch in diameter and form a 6 x 10.75 inch rectangle. See Figure 3.

It is recommended to use #8 drywall anchors and screws for mounting the **ISA-60M** to a drywall/sheetrock surface.



**Non-magnetic mounting hardware is required for control panels located in the magnet room.**

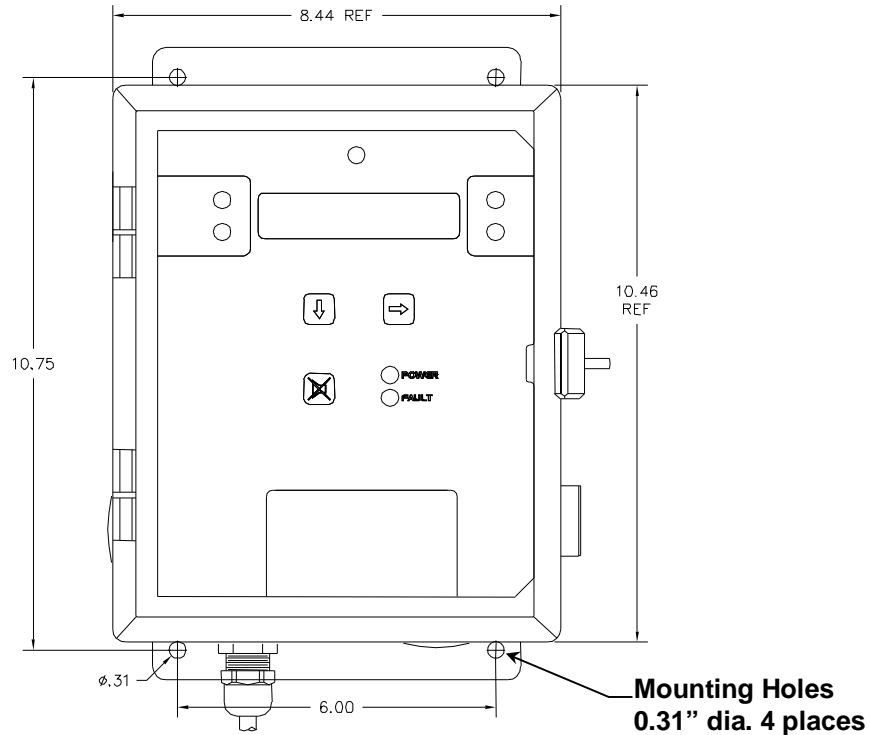

Dimensions are in inches.

**Figure 3: ISA-60M Mounting Dimensions**

#### 3.2 Mounting MRI-5175 Remote Sensor

Mount each **MRI-5175** remote sensor such that it samples the ambient air in the MRI environment.

It is recommended to use #8 drywall anchors and screws for mounting the **ISA-60M** to a drywall/sheetrock surface.



**Non-magnetic mounting hardware is required.**

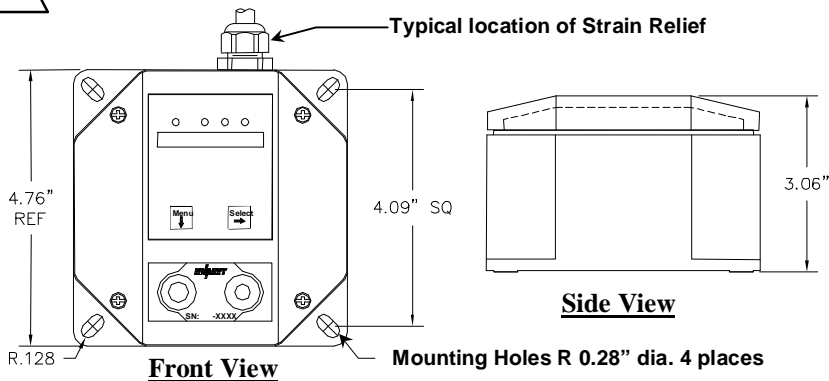

Dimensions are in inches.

**Figure 4: MRI-5175 REMOTE SENSOR Mounting Dimensions**

**NOTE:** Remote Sensor, Each must be connected to a 4-20mA input inside the **ISA-60M**. UL listed type CM, PLTC or TC cable shall be used for wiring between the **MRI-5175** and the **ISA-60M** control panel. Three conductor, 18 gauge **shielded** wiring for runs up to 1000 feet. For 500 feet or shorter wiring runs, 20 gauge **shielded** wiring is acceptable. The supplied strain reliefs are rated for cable with an OD between 0.20 – 0.35 inches.

### 3.3 Power Supply

The input power can vary from 100 to 240VAC, 50/60 Hz. Mains power should be connected to the Power Input Terminal J23 and the ground screw J21. See **Figure 5** for location.

**! WARNING: Continuous gas detection and alarm systems become inoperative upon loss of primary power.**

Upon supplying air and power to the **ISA-60M**:

- The green power on LED is lit.
- The display backlight is lit, and instrument will step through a start-up sequence: unit serial number, software revision and gases monitored may be shown on the display.

The instrument may go into alarm briefly, but the sensors stabilize quickly. If the instrument persists in alarm, acknowledge the alarm by pressing the **AUDIO DEFEAT /ALARM ACKNOWLEDGE** switch. If alarm persists longer than 30 minutes, call **ENMET** customer service personnel.

Mains power line is fused for power supply protection. Fuse is 5 x 20mm, 0.630Amp is located in FH2, see **Figure 5**

### 3.4 Wiring ISA-60M to MRI-5175

Wiring for the **MRI-5175** alarm, relay contacts and 4-20mA outputs may be routed through one of the two enclosure punch-outs on the side or bottom of the enclosure. See Figure 1. Follow state and local guidelines when selecting appropriate strain relief, conduit and wiring.

Remote Sensor: Each must be connected to a 4-20mA input inside the **ISA-60M**. UL listed type CM, PLTC or TC cable shall be used for wiring between the **MRI-5175** and the **ISA-60M** control panel. Three conductor, 18 gauge *shielded* wiring for runs up to 1000 feet. For 500 feet or shorter *shielded* wiring runs, 20 gauge wiring is acceptable. The supplied strain reliefs are rated for cable with an OD between 0.20 – 0.35 inches.

#### 3.4.1 Outputs

Two types of alarm outputs are available, relay contacts and 4-20mA outputs.

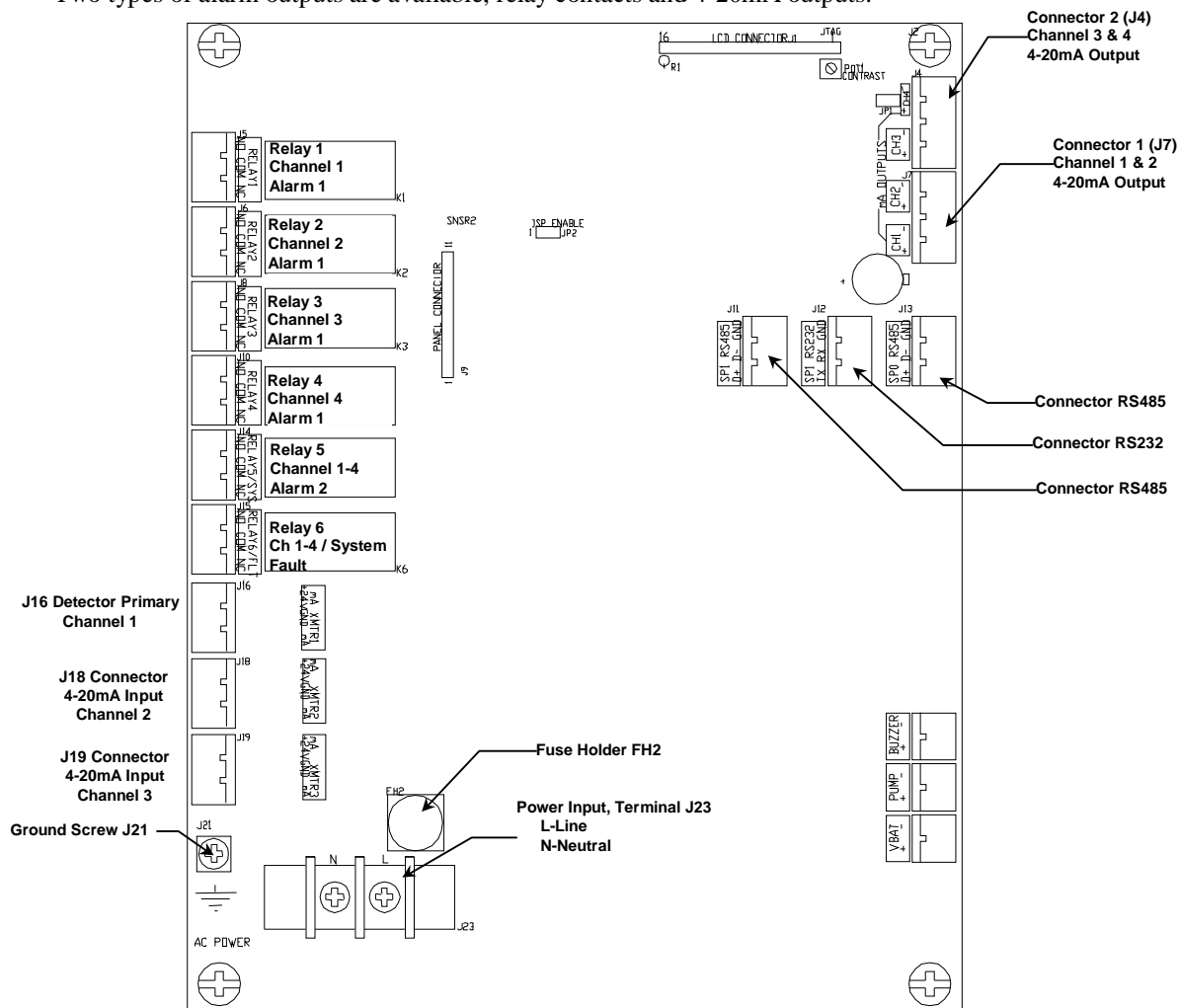

**Figure 5: ISA-60M Relay, Input and Output Terminals**

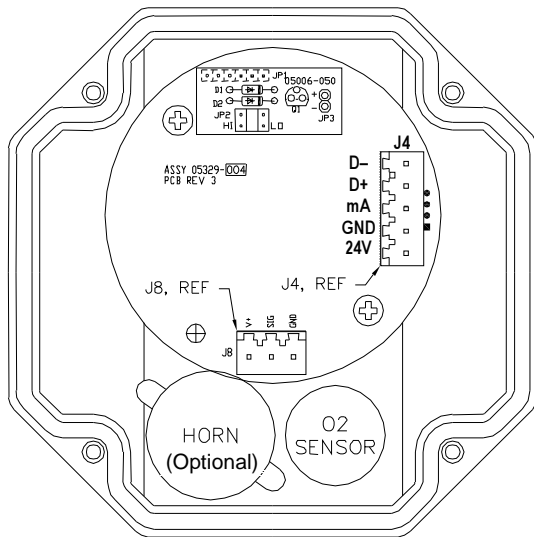

MRI-5175 Lid, interior view

Figure 5A: MRI-5175 Input and Output Terminals

Table 1: Wiring ISA-60M to MRI-5175

ISA-60M		MRI-5175
<b>Channel 1, J16</b>		<b>Channel 1, J4</b>
+24V (1)	Power	+24V
GND (2)	Ground	GND
mA (3)	Signal	mA
<b>Channel 2, J18</b>		<b>Channel 2, J4</b>
+24V	Power	+24V
GND	Ground	GND
mA	Signal	mA
<b>Channel 3, J19</b>		<b>Channel 3, J4</b>
+24V	Power	+24V
GND	Ground	GND
mA	Signal	mA

### 3.4.2 ISA-60M Relay Contacts

Relay contacts are available for each alarm; these are SPDT, rated at 10Amp at 110VAC or 10Amp at 30VDC for restive loads, and may be latching or non-latching as required by the application. They are accessed on the terminals next to each relay see **Figure 2 & 5**. The contact positions are noted on the circuit board next to each terminal.

These relay coils are energized when they are in the non-alarm state; the contact conditions given above are for the non-energized state, which is identical to the alarm state.

In addition, there is a fault relay, which changes state whenever the instrument is in a fault condition. The contact positions are noted on the circuit board next to each terminal. The coil of this relay is energized when the instrument is in the non-fault state; the contact conditions given on the circuit board next to the terminal, are for the non-energized state, which is identical to the fault state.

The PC Board is labeled for the relays in their un-energized state. If the relay is configured for failsafe, then this is also the alarm condition state. Non-failsafe configured relays in the alarm state, are the reverse of the PC board labeling. Note that the Fault(FLT) relay cannot be set to operate in a Non-Failsafe mode. Please see the **Table 2** below:

Table 2 : Relay Failsafe Settings

Position	Failsafe-Alarm	Non-Failsafe-Alarm
J5 Relay 1 - NO	Normally Open	Normally Closed
J5 Relay 1 - COM	Common	Common
J5 Relay 1 - NC	Normally Closed	Normally Open
J6 Relay 2 - NO	Normally Open	Normally Closed
J6 Relay 2 - COM	Common	Common
J6 Relay 2 - NC	Normally Closed	Normally Open
J8 Relay 3 - NO	Normally Open	Normally Closed
J8 Relay 3 - COM	Common	Common
J8 Relay 3 - NC	Normally Closed	Normally Open
J10 Relay 4 - NO	Normally Open	Normally Closed
J10 Relay 4 - COM	Common	Common
J10 Relay 4 - NC	Normally Closed	Normally Open
J14 Relay 5 - NO	Normally Open	Normally Closed
J14 Relay 5 - COM	Common	Common
J14 Relay 5 - NC	Normally Closed	Normally Open
J15 Relay 6/FLT - NO	Normally Open	N/A
J15 Relay 6/FLT - COM	Common	N/A
J15 Relay 6/FLT - NC	Normally Closed	N/A

These relay contacts can be used to operate auxiliary alarms or other functions.

### 3.4.3 4-20mA Outputs

Isolated 4-20 mA outputs are available for data logging or other purposes. An output is supplied for each sensor supplied in a particular instrument, and can be added when a sensor is added in the field. These outputs are available on the Connector 1(J7) for channels 1 & 2 and Connector 2(J4) for channels 3 & 4.

4mA corresponds to the sensor reading of 0 at the bottom of the range.

20mA corresponds to a full scale reading of 30.

Wiring requirements are the same as for the relays.

### 3.4.4 Digital Outputs

The RS232 & RS485 connections are used for firmware updates and digital communications. The **ISA-60M** is designed to operate as a modbus slave. Contact the **ENMET** for further information on wiring for the digital outputs.

## 3.5 Initial Calibration

All instruments are calibrated at the factory. You may, if a calibration kit is available, calibrate the **MRI-5175** 3 – 4 hours after installation. **See Section 5.0, Maintenance**, for calibration instructions.

## 4.0 Operation

### 4.1 Normal Operation Condition

With the **ISA-60M** installed as described in **Section 3**, and in clean air, the **POWER** green LED is on, the display is lit, and the information on the display is as shown in **Figure 6**, for the sensor(s) installed in the **ISA-60M**. The red alarm and fault LEDs are not lit.

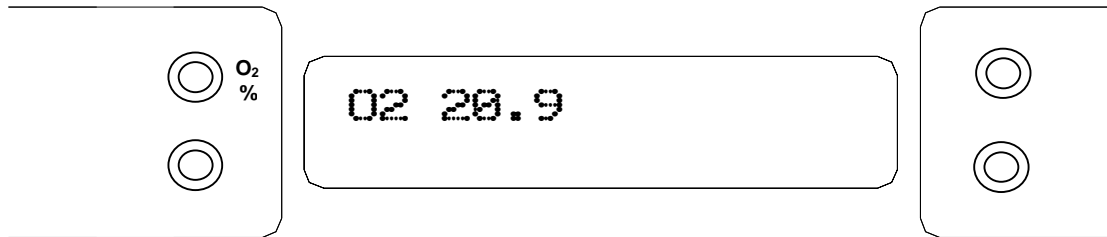

*Example of display*

**Figure 6: ISA-60M Operational Display**

### 4.2 Alarm Set Points

There are two alarm set points for each active oxygen channel. They are adjustable from 16.0 to 24.9. The factory settings of these alarm set points are:

**Alarm 1** is 19.5 % by volume, indicated by Flashing LED and audio alarm.

**Alarm 2** is 17 % by volume, indicated by Steady LED and alarm 1 LED changes from flashing to steady.

These alarm set points can be changed within limits; see the maintenance section of this manual for the procedure.

- If the oxygen content of the sample air decreases below an alarm set point, the associated red LED activates, the associated relay changes state, and the audio alarm is activated.

#### Differential Setting

Differential is an optional alarm relay configuration where when an alarm has been triggered, the relay will remain in alarm state until the sensor reading has moved the differential “value” in the non-alarm direction. See example below.

- The Alarm 1 differential value is the delay of the **ISA-60M** staying in alarm condition until after the measured reading has returned past the alarm point by the differential value. *Example:* If the alarm point is V 19.5 and the differential is 2, the **ISA-60M** will go into alarm at 19.5 and stay in alarm until the reading has risen above 21.5.

### 4.3 Alarm Latching

An instrument is shipped with the alarms in the latching mode. The alarms may be independently configured in the non-latching mode or differential setting by use of the maintenance menu. *See Section 5.2.2*, for setting alarm 1 and alarm 2.

#### Standard Setting

- IN THE LATCHING MODE: at the cessation of the condition which causes an alarm, the alarm indications do not cease, and the alarm relay contacts do not revert to the non-alarm state, until the **ALARM ACKN/AUDIO DEFEAT** switch is pressed. An alarm can also be acknowledged by pressing the switch during the alarm condition; then at the cessation of the alarm condition, alarm indications cease and alarm relays revert to the non-alarm state. After an alarm is acknowledged, alarms in the latching configuration are re-armed to latch at the next alarm condition.
- IN THE NON-LATCHING MODE: at the cessation of the condition that causes an alarm, the alarm indications automatically cease, and the alarm relay contacts revert to the non-alarm state.

### 4.4 Audio Defeat

Pressing the **AUDIO DEFEAT / ALARM ACKNOWLEDGE** switch during an alarm temporarily silences the audio alarm on the **ISA-60M** not on the **MRI-5175**. Relays and alarm LEDs continue to function, in the alarm state, during an alarm condition. As long as the alarm condition persists, the audio alarm will “chirp” every 20 seconds. After the alarm condition clears, the audio will continue to “chirp” until the audio switch is pressed.

- If after 15 minutes the alarm condition continues the audio alarm will reactivate at full intensity.
- If any other alarm condition occurs while the audio alarm has been silenced it will force the audio alarm to reactivate immediately.

### 4.5 Display

In clean air a display is shown in **Figure 4**. This position of the display is termed the "**operational display**". As explained below, the display can be changed to furnish other information by using the **OPTION** and **SELECT** switches.

Oxygen concentration is given in percent by volume.

### 4.6 Operational Menu

The operational menu allows the user to:

- View alarm set point concentration values
- View alarm latching configurations
- Enter the maintenance menu with the proper Password.

The operational menu is accessed with the **OPTION** and **SELECT** switches. The operational menu flow chart is shown in **Figure 7**,

- Pressing the **OPTION** switch is indicated with a "O"
- Pressing the **SELECT** switch is indicated with a "S".

If the instrument is left at any location in the operational or maintenance menus, other than the operational display, with no action taken for a period of 45 seconds, it returns to the operational display.

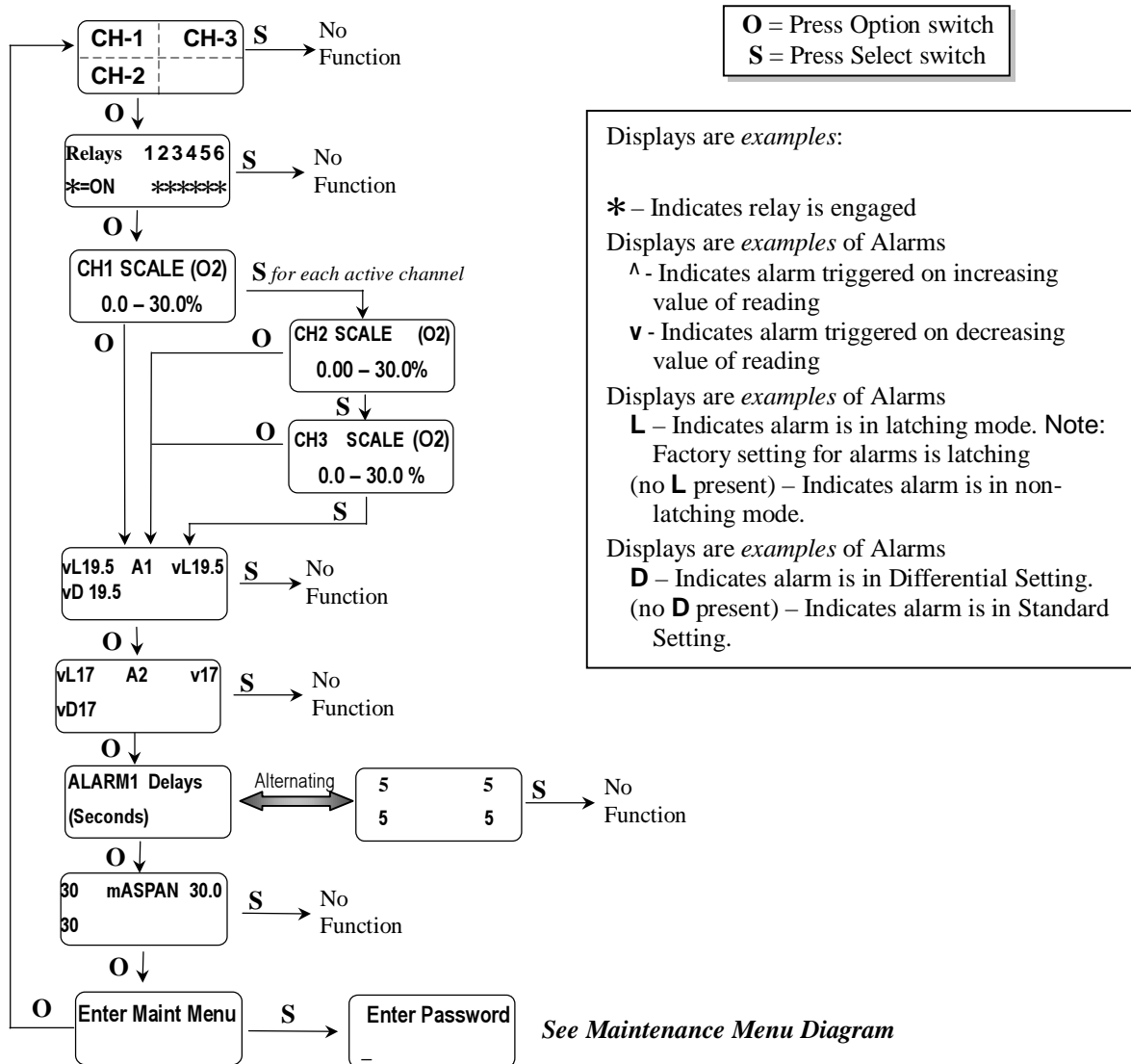

**Figure 7: ISA-60M Operation Menu Flow Chart**

### 4.7 Fault Indications

Fault indications are associated with sensor zero and calibration activities, and are described in the maintenance **section 5.0** of this manual.

## 5.0 Maintenance

The ISA-60M has no specific preventative maintenance requirements. Entering the maintenance menu, as outlined in Section 5.2 may change instrument configurations.

The MRI-5175 sensor will require periodic calibration and replacement. Oxygen sensor calibration should be performed on at least a quarterly basis. The sensor has an estimated lifetime of 5 years. The sensor should be replaced when it will not calibrate or shortly before the 5 year time frame, to ensure continuous instrument operation. Sensor calibration instructions can be found in Section 6.0.

### 5.1 Cleaning Instructions

**CAUTION:** Never spray a cleaning solution on the surfaces of the ISA-60M or MRI-5175 devices.

Clean the exterior of the ISA-60M and MRI-5175 enclosures with a mild soap solution on a clean, damp cloth. Do not soak the cloth with solution so that moisture drips onto, or lingers on, external surfaces.

Under no circumstances should organic solvents such as paint thinner be used to clean instrument surfaces.

### 5.2 Maintenance Menu ISA-60M

The maintenance menu diagram is shown in Figure 8 Maintenance Menu Flow Chart. From the operational display, press the OPTION switch 4 times; "Enter MAINTENANCE Menu" is displayed.

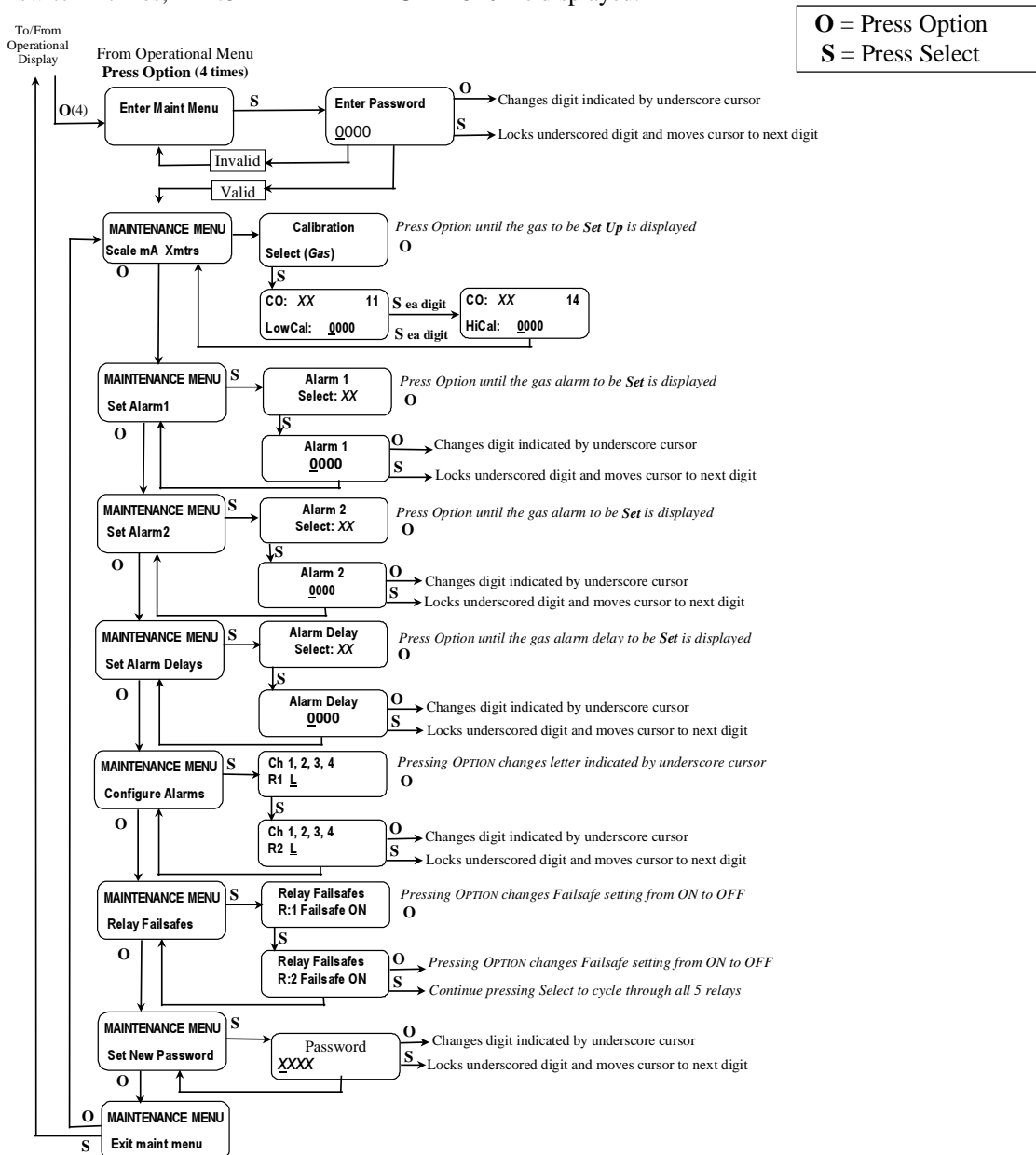

Figure 8: ISA-60M Maintenance Menu Flow Chart.

**5.2.1 Set 4 –20mA Transmitter Scale**

This section of the maintenance menu is for the external sensor/transmitters **MRI-5175**. This function is normally performed at the factory and is not usually required in the field unless a new transmitter with a different range is installed.

After entering a valid password into maintenance menu, the Scale mA Xmtrs section is the second menu section, if it is installed, enter by pressing the **SELECT** switch

- Press the **SELECT** switch "mA Xmter Scale: Select XX" is displayed. XX = the gas to be set up.
- Press the **OPTION** switch, if needed, to change to the gas to be set up.
- Press the **SELECT** switch, "Ch#: mAXmter: 4mA: 0000" is displayed
- Press the **SELECT** switch, that moves the cursor one digit to the right when the last digit is accepted the display move to the full Scale mA Xmtrs menu
- Press the **SELECT** switch, "Ch#: mAXmter: 20mA: 0000" is displayed
- Press the **SELECT** switch, that moves the cursor one digit to the right when the last digit is accepted the display will return to the Scale mA Xmtrs menu
- Repeat these steps for each 4 –20mA transmitter.
- Press the **OPTION** switch, to continue on to the next section of the Maintenance Menu.

*Example: Sensor/Transmitter Set Up Flow Chart*

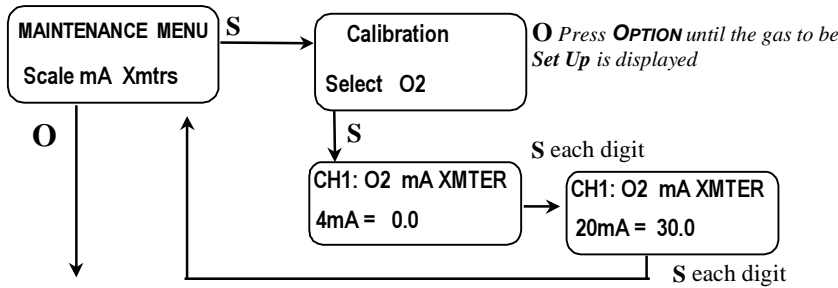

**Table 3: Set up values**

Gas	4mA	20mA
O <sub>2</sub>	0	30

### 5.2.2 Set Alarm Points

Factory alarm set points are discussed in Section 4.2, See Table 2. To change the alarm points, you must enter the maintenance menu.

NOTE: Changing the alarm points on the **ISA-60M** will NOT change the alarm points on the **MRI-5175** sensor transmitter.

Entrance to the maintenance menu is guarded with a four-digit Password. The factory default setting of the password is 1270. When a valid numerical password is inserted, the user is allowed to enter the maintenance menu.

In the "Enter Maint Menu" position

- Press the **SELECT** switch "Enter Password █ 0" is displayed. Press **SELECT** switch once, to move cursor to next digit, this will be the first digit of the password.
- In the █000 position, the underline cursor is under the left digit.
- Press the **OPTION** switch to change the left digit; select the correct digit.
- Press the **SELECT** switch, which locks the digit in place and moves the cursor one digit to the right.

Continue this process until the four-digit password is complete. When a valid password is inserted in this manner, the display is transferred to the "Calibration" portion of the menu. If an invalid password is inserted you are returned to the Enter Maint Menu display.

After entering a valid password:

- Press the **OPTION** switch until; "Maintenance Menu Set Alarm1" appears on display.
- Press the **SELECT** switch, "ALARM1 Select: O2" is displayed.
- Press the **SELECT** switch; "ALARM 1 V" is displayed, with the indicator flashing,  $\Lambda$  for ascending trigger point or V for descending trigger point indicator.
- Press the **OPTION** switch to toggle between  $\Lambda$  and V; select the correct indicator.
- Press the **SELECT** switch to lock in the correct indicator. "ALARM 1 STD" is displayed
- Press the **OPTION** switch to toggle between **STD** and **DIFF**; select the correct indicator.
- Press the **SELECT** switch to lock in the correct indicator.

IF: **STD** is selected, "ALARM 1 VL " is displayed.

- The next character is the latching indicator **L** or **NOL** press the **OPTION** switch to toggle the latching mode.
  - The next characters are the alarm 1 value, press the **OPTION** switch to select each digit of the value
- When the last digit is accepted display returns to the Maintenance Menu "Set Alarm1" position.

IF: **DIFF** is selected, "ALARM 1 V DIFF 19.5" is displayed, Factory default setting.

- The next characters are the alarm 1 value, press the **OPTION** switch to select each digit of the value
- Move the cursor to the first digit and, Press the **SELECT** switch to lock in the correct character and move the cursor to the right.
- "ALARM 1 DIFF BAND 0.0" is displayed, to *set alarm 1 differential*. With **SELECT** switch move cursor to left.
- Press the **OPTION** switch to select each digit of the value.

Note: The Alarm 1 differential value is the delay of the **ISA-60M** staying in alarm condition until after the measured reading has returned past the alarm point by the differential value. *Example: If the alarm set point is V 19.5 and the differential is 2, the **ISA-60M** will go into alarm at 19.5 and stay in alarm until the reading has risen above 21.5.*

- Repeat the above procedure for each sensor alarm 1 to be changed.
- Press the **OPTION** switch to move to alarm 2, "Set ALARM2" is displayed.
- Repeat as for alarm 1 using the **STD** section. Alarm Diff is not available for Alarm 2.
- Press **OPTION** switch until "Exit maint menu" appears, then press **SELECT** switch to return the instrument to the Operational Display

Example: Set Alarms Flow Chart

Displays shown are factory default settings.

Λ - Indicates alarm triggered on increasing value of reading

v - Indicates alarm triggered on decreasing value of reading

L - Indicates alarm is set for latching

noL - Indicates alarm is set for non-latching

STD – Indicates alarm in standard setting, can be set in latched or non-latched mode

DIFF – Indicates alarm in differential setting, instrument will stay in alarm beyond the alarm set point by the differential value

O = Press Option  
S = Press Select

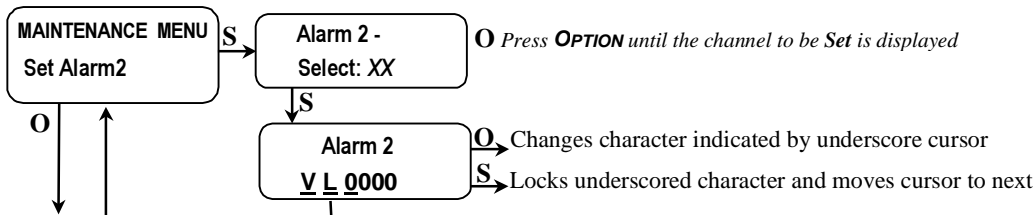
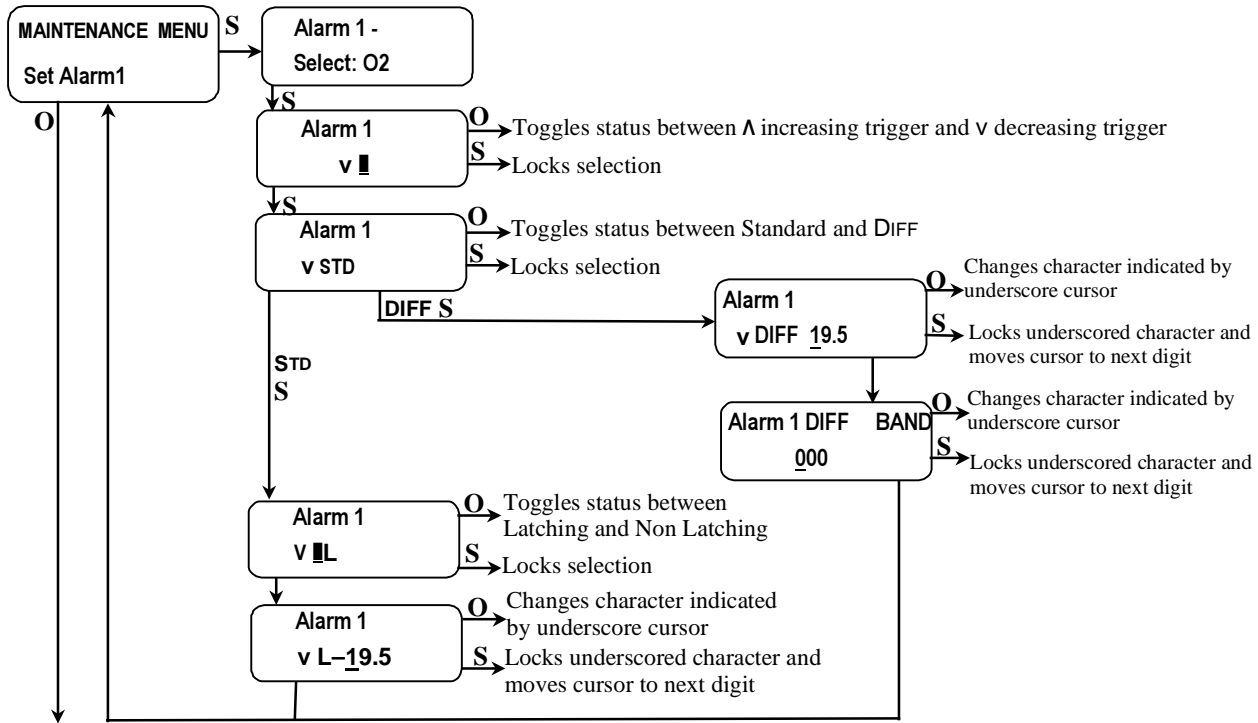

### 5.2.3 Set Alarm “Delay On”

The alarms may be set to delay activation by 1 second increments.  
 Factory set default value is 5 seconds.

After entering a valid password:

- Press the **OPTION** switch until; “Maintenance Menu Set Alarm Delay” appears on display.
- Press the **SELECT** switch, "ALARM Delay Select: O2" is displayed.
- Press the **SELECT** switch; "ALARM Delay = 0005" is displayed, with the underscore cursor under the left position.
- Press the **SELECT** switch to move the cursor and the **OPTION** switch to lock in the correct digit and move the cursor one digit to the right. Press the **SELECT** switch when the last digit is accepted display returns to the "Set Alarm Delay" position.
- Press the **OPTION** switch to continue on to the Set New Password section

Example: Set Alarm Delay Flow Chart

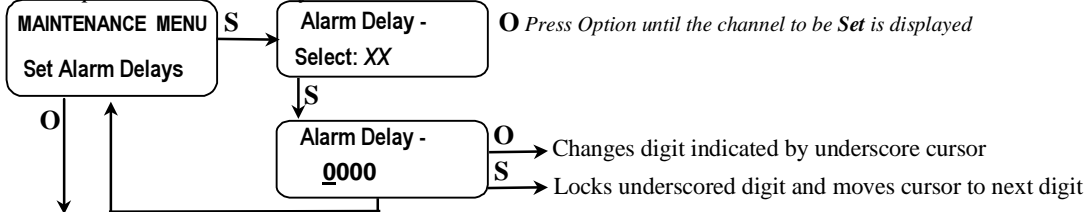

### 5.2.4 Relay Configuration

To change a relay configuration you must enter the maintenance menu. Press the **OPTION** switch until “Enter Maint Menu” is displayed then press **SELECT** switch for the Enter Password menu. Enter the valid password as described below.

In the "Enter Maint Menu" position

- Press the **SELECT** switch "Enter Password 0" is displayed. Press **SELECT** switch once, to move cursor to next digit, this will be the first digit of the password.
- In the 0000 position, the underline cursor is under the left digit.
- Press the **OPTION** switch to change the left digit; select the correct digit.
- Press the **SELECT** switch, which locks the digit in place and moves the cursor one digit to the right. Continue this process until the four-digit password is complete. When a valid password is inserted in this manner, the display is transferred to the "Calibration" portion of the menu. If an invalid password is inserted you are returned to the Enter Maint Menu display.

After entering a valid password:

- Press the **OPTION** switch until “Configure Alarms” is displayed  
**L** = Low Alarm = Alarm 1, **H** = High Alarm = Alarm 2, **B** = Both Alarms, **□** = No Relay linked to channel

Example: Set Relay Configuration Flow Chart

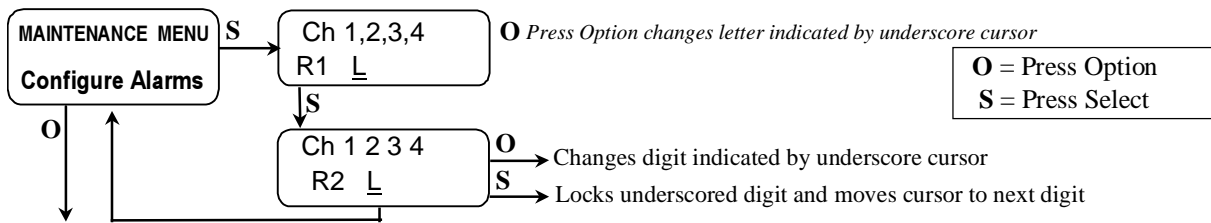

The **Table 4** below shows the default relay links.

**Table 4: Default Relay Links**

	Channel 1	Channel 2	Channel 3	Channel 4
Relay 1	Low Alarm			
Relay 2		Low Alarm		
Relay 3			Low Alarm	
Relay 4				Low Alarm
Relay 5	High Alarm	High Alarm	High Alarm	High Alarm

Relays can be linked to specific alarms.

NOTE: Each operating channel must be linked to at least 1 relay.

### 5.2.5 Failsafe Configuration

The **ISA-60M** is factory set in a failsafe configuration. This means that if power is disconnected to the unit, or the relay fails to properly engage, it fails in such a way that it is in the alarm position. **ENMET** recommends leaving the relay in a failsafe configuration. However, relay 1 – 5 can be re-configured by using the following procedure.

To change a relay failsafe configuration you must enter the maintenance menu. Press the **OPTION** switch until "Enter Maint Menu" is displayed then press **SELECT** switch for the Enter Password menu. Enter the valid password as described below.

In the "Enter Maint Menu" position

- Press the **SELECT** switch "Enter Password █ 0" is displayed. Press **SELECT** switch once, to move cursor to next digit, this will be the first digit of the password.
- In the █000 position, the underline cursor is under the left digit.
- Press the **OPTION** switch to change the left digit; select the correct digit.
- Press the **SELECT** switch, which locks the digit in place and moves the cursor one digit to the right. Continue this process until the four-digit password is complete. When a valid password is inserted in this manner, the display is transferred to the "Calibration" portion of the menu. If an invalid password is inserted you are returned to the Enter Maint Menu display.

After entering a valid password:

- Press the **OPTION** switch until "Relay Failsafes" is displayed

Example: Set Relay Failsafe Configuration Flow Chart

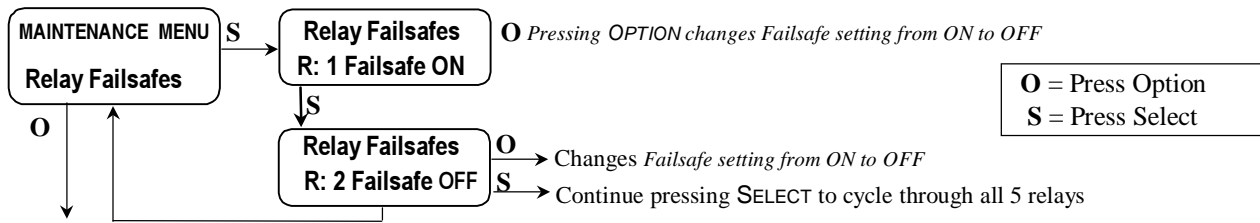

### 5.2.6 Set New Password

To change the password, you must enter the maintenance menu. Press the **OPTION** switch until "Enter Maint Menu" is displayed then press **SELECT** switch for the Enter Password menu. Enter the valid password as described in Section 5.2.1.

To set a new password, after inserting a valid password,

- Press the **OPTION** switch until; "Set New Password" is displayed.
- Press the **SELECT** switch; "Password █1270" is displayed, with the underscore cursor under the left digit.
- Use the **OPTION** switch to change the left digit, when the desired digit is displayed.
- Press the **SELECT** switch to lock the digit in place and move the cursor one digit to the right.

When all four digits of the new password have been selected, "Set New Password" is displayed.

Record the new password; without it, the maintenance menu cannot be reentered once you exit the Maintenance Menu. If the password is lost, call **ENMET** customer service personnel.

From the "Password XXXX" position,

- Press the **SELECT** switch to return to Set New Password section.
- Press the **OPTION** switch; to continue to "exit MAINTENANCE Menu"

Example: Set Password Flow Chart

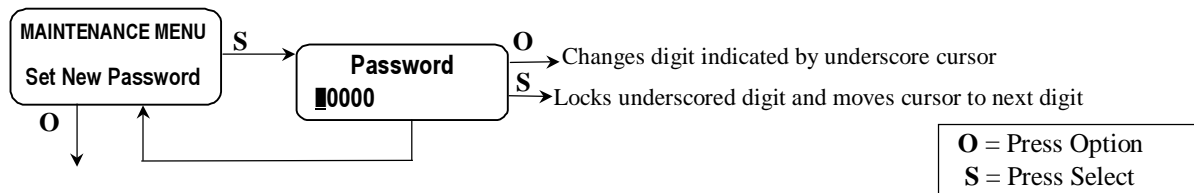

### 5.2.7 Exit Maintenance Menu

From the "exit MAINTENANCE Menu" position

Press the **SELECT** switch to resume the operational display.

Press the **OPTION** switch to reenter the maintenance menu at the "Calibration" position.

Example: Exit Maintenance Menu Flow Chart

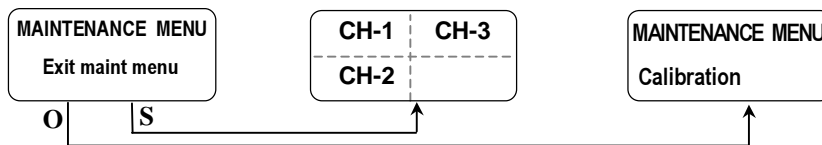

## 5.3 MRI-5175 Sensor Transmitter

The **MRI-5175** is supplied with 3 alarm points:

2 are factory set to match the **ISA-60M**

The 3<sup>rd</sup> is set at 23.5 as an oxygen abundance indicator.

The alarm points are not field adjustable.

When equipped with an audio alarm for safety reasons this alarm can not be silenced when triggered by an unsafe condition.

## 6.0 Maintenance MRI-5175

The **MRI-5175** sensor will require periodic calibration and replacement. Oxygen sensor calibration should be performed on at least a quarterly basis. The sensor has an estimated lifetime of 5 years. The sensor should be replaced when it will not calibrate or shortly before the 5 year time frame, to ensure continuous instrument operation.

### 6.1 MRI-5175 Calibration

Calibration is performed at the **MRI-5175** remote sensor/transmitter. The **ISA-60M** has directly been aligned to the Output of the **MRI-5175** sensor/transmitter.

Calibration is the process of setting the instrument up to read accurately when exposed to a target gas.

**Initial Calibration:** Wait at least 3 – 4 hours after initially supplying power to the **MRI-5175** sensor/transmitter before initial calibration, Overnight stabilization is preferred before calibration. The sensor has been pre-calibrated at the factory, and initial field calibration should result in only fine tuning the circuit, as well as a way to check that installation is successful. It is not necessary to open the enclosure to make adjustment. The calibration functions are operated through the **MENU** and **SELECT** switches. See **Table 5** for Power/Fault LED Sequence codes.

**ENMET** Corporation recommends at least quarterly calibration of the **MRI-5175** transmitters.

To enter Calibration:

Press and **hold MENU** switch for 3 to 5 seconds, Power/Fault LED will flash a *rapid* Exit sequence, **green-red-green-red-...** See **Table 5** for Power/Fault LED Sequence codes.

To calibrate, press the **MENU** switch, then **SELECT** switch will enter Span sequence

While in Span sequence Power/Fault LED will flash **green-red-red-red-...** Attach the calibration adapter to the **MRI-5175** see Figure 9, attach the calibration 20.9% gas and allow the gas to flow to the sensor. See Figure 9

After 30 seconds the **MRI-5175** will monitor the sensor signal, looking for the sensor to stabilize the output from the calibration gas when stabilized:

IF signal is within tolerance, Power/Fault LED will remain **green for 3 seconds** indicating Cal Ok, and then return to **green-red – green-red ...** calibration sequence.

To exit, press the **SELECT** switch, to return to operation mode

IF signal is not within tolerance, the Power/Fault LED will remain **red for 3 seconds** indicating a Bad Cal and then return to **green-red -green-red -...** sequence

Remove the calibration adapter and verify the calibration gas is correct. Let the sensor stabilize for 5 to 10 minutes.

To repeat, calibration press **MENU** switch, the **SELECT** switch to enter Span sequence

Note: Following a Bad Cal sequence if the **MRI-5175** is not successfully calibrated and left in the Cal/Maintenance mode the sensor transmitter will initiate a *slow* Bad Cal sequence **red-green-red-green-...** and the **ISA-60M** will exit the cal menu.

To exit, press the **SELECT** switch, to return to operation mode

**Table 5: Fault LED Code Sequence**

Power/Fault LED Code	Indication Sequence
Exit	Green-red – green-red – green red-...
Span	Green-red-red-red – green-red-red-red – green-red-red-red...
Cal OK	Green for 3 seconds
Bad Cal	Red for 3 seconds

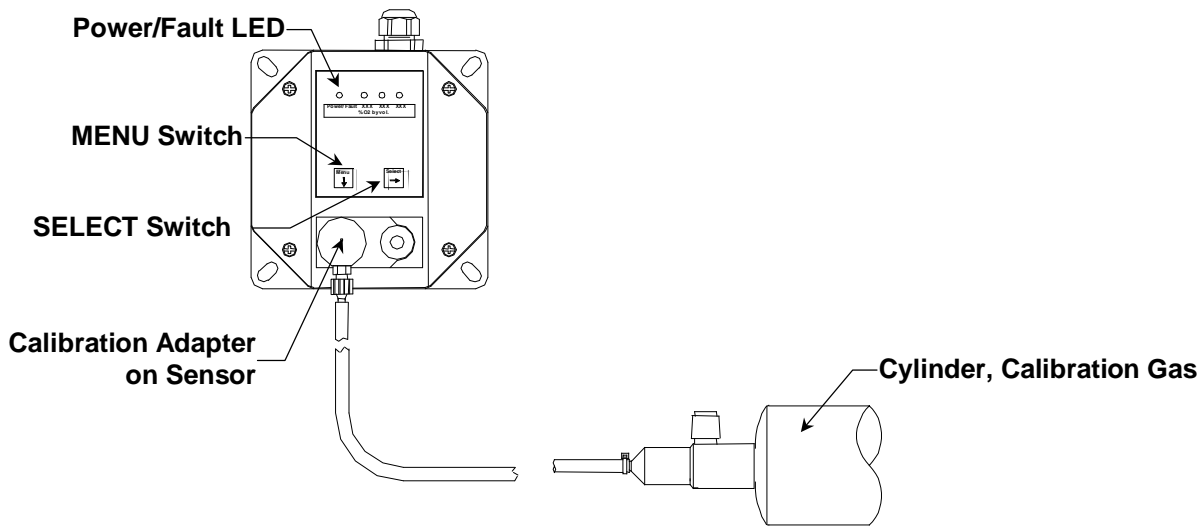

**Figure 9: Calibration MRI-5175**

### 6.2 Sensor Replacement

An Oxygen sensor must be replaced when it can no longer be calibrated. Typical sensor life is 3 to 5 years in a 20.9% oxygen environment.

To replace a sensor, perform the following steps:

- Turn off the electrical power.
- Open the display panel and remove the four cover (lid) retention screws and remove the lid. See **Figure 10**.
- Remove the old O<sub>2</sub> sensor, by unscrewing it, and replace it with a new sensor. See **Figure 10**.
- Replace cover(lid) with retention screws.
- Turn on the electrical power.
- Wait 3 – 4 hours, then recalibrate the sensor per the instructions in **Section 6.1**.

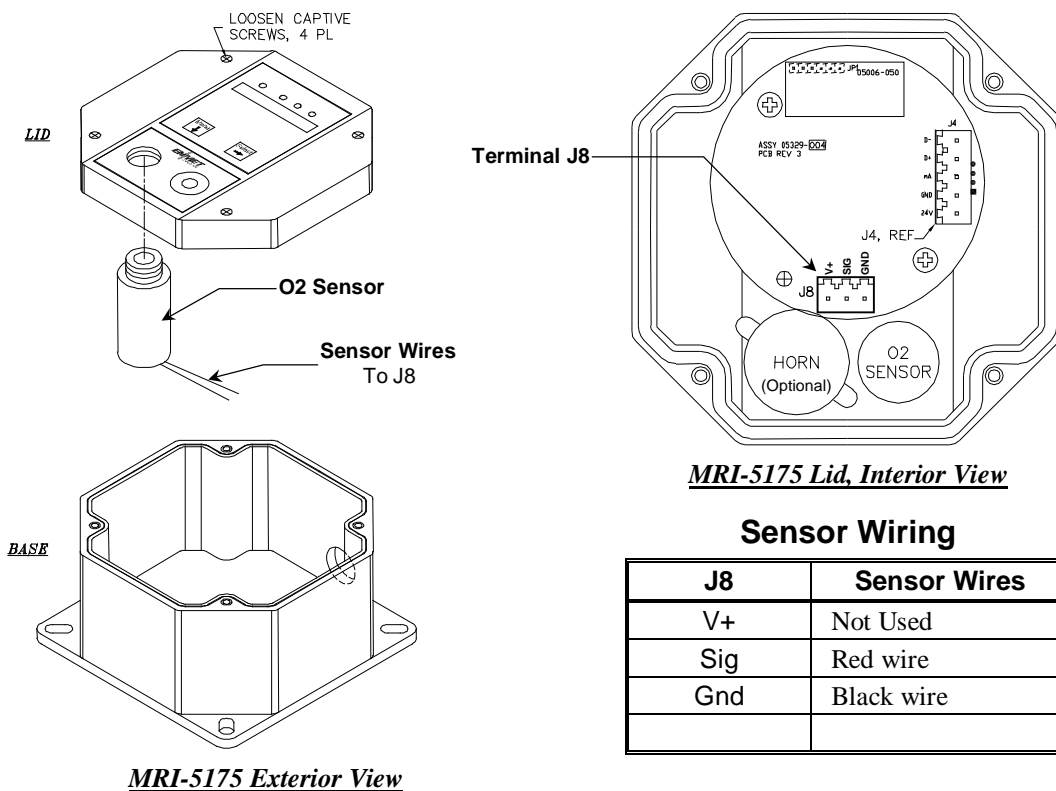

**Figure 10: MRI-5175 Sensor Replacement**

## 7.0 Technical Data and Specifications

<b>Electrical Power</b>	15 Amp fused branch circuit	
	100-240 VAC	
	0.9 A	
	50/60 Hz	
	Board Mounted Fuse FH2, 0.630A, 5 x 20mm	
<b>Storage and Transport</b>	<i>(to also be included on shipping box)</i>	
	Temperature:	-20° to +60°C (-4° to +140°F)
	<i>preferred</i>	0° to +20°C (32° to 68°F)
	Relative Humidity	10-99% RH, non-condensing
	Atmospheric Pressure	20 to 36 inHg (68 to 133 kPa)
<b>Operation</b>	Temperature:	0° to +40°C (32° to +104°F)
	Relative Humidity	10-99% RH, non-condensing
	Atmospheric Pressure	20 to 36 inHg (68 to 133 kPa)
<b>Mechanical</b>		
<b>ISA-60M</b>	Dimensions:	11 x 9 x 6 inches (4.3 x 3.5 x 2.4 cm)
	Weight:	8 lbs (3.6 kg)
	Strain relief:	5 – 12 mm OD
	Material:	Engineered thermoplastic with hinged front cover Non-magnetic hardware
<b>MRI-5175</b>	Dimensions:	5 x 5 x 4 inches (2 x 2 x 1.6 cm)
	Weight:	2 lbs (0.9 kg)
	Strain relief:	5 – 12 mm OD
	Material:	Fiberglass-reinforced polyester Non-magnetic hardware
<b>Outputs</b>		
<b>ISA-60M</b>	Relays:	SPDT Resistive Load Inductive Load 10A at 110 VAC 7.5A at 110 VAC 10A at 30 VDC 5A at 30 VDC
	Analog:	4-20 mA x 3
	Digital:	RS-232 – Modbus RS-485 – Modbus
	Audio:	90 db at 2 ft
<b>MRI-5175</b>	Analog	4-20 mA
	Digital:	RS-485 – Modbus
	Audio:	90 db at 2 ft

**NOTE:** All specifications stated in this manual may change without notice.

## 8.0 Replacement Part Numbers

ENMET part numbers for replacement parts:

Part number	Description
67016-1152	Sensor, Oxygen
64002-630	Fuse, 0.630 Amp 5x20mm
03296-209	Gas Cylinder, 20.9% oxygen in nitrogen, 17 liter
03100-209	Gas Cylinder, 20.9% oxygen in nitrogen, 11 liter
03700-037	Calibration Adapter, 34/17 liter regulator
03620-021	Calibration Cover, <b>MRI-5175</b>
65057-011	Terminal plug, 3 position
65057-012	Terminal plug, 4 position
65057-010	Terminal plug, 2 position

## 9.0 WARRANTY

ENMET warrants new instruments to be free from defects in workmanship and material under normal use for a period of one year from date of shipment from ENMET. The warranty covers both parts and labor excluding instrument calibration and expendable parts such as calibration gas, filters, batteries, etc... Equipment believed to be defective should be returned to ENMET within the warranty period (transportation prepaid) for inspection. If the evaluation by ENMET confirms that the product is defective, it will be repaired or replaced at no charge, within the stated limitations, and returned prepaid to any location in the United States by the most economical means, e.g. Surface UPS/FedEx Ground. If an expedient means of transportation is requested during the warranty period, the customer is responsible for the difference between the most economical means and the expedient mode. ENMET shall not be liable for any loss or damage caused by the improper use of the product. The purchaser indemnifies and saves harmless the company with respect to any loss or damages that may arise through the use by the purchaser or others of this equipment.

This warranty is expressly given in lieu of all other warranties, either expressed or implied, including that of merchantability, and all other obligations or liabilities of ENMET which may arise in connection with this equipment. ENMET neither assumes nor authorizes any representative or other person to assume for it any obligation or liability other than that which is set forth herein.

NOTE: When returning an instrument to the factory for service:

- Be sure to include paperwork.
- A purchase order, return address and telephone number will assist in the expedient repair and return of your unit.
- Include any specific instructions.
- For warranty service, include date of purchase
- If you require an estimate, please contact ENMET Corporation.

There is Return for Repair Instructions and Form on the last pages of this manual. This form can be copied or used as needed.

### Manual Part Number

80003-500

April 2006

MCN-351, 02/09/07

MCN-378, 07/25/07

MCN-394, 11/26/07

MCN-397, 02/04/08



PO Box 979  
680 Fairfield Court  
Ann Arbor, Michigan 48106-0979  
734.761.1270 Fax 734.761.3220

# Returning an Instrument for Repair

**ENMET** instruments may be returned to the factory or any one of our Field Service Centers for regular repair service or calibration. The **ENMET** Repair Department and Field Service Centers also perform warranty service work.

When returning an instrument to the factory or service center for service, paperwork must be included which contains the following information:

- A purchase order number or reference number.
- A contact name with return address, telephone and fax numbers
- Specific instructions regarding desired service or description of the problems being encountered.
- Date of original purchase and copy of packing slip or invoice for warranty consideration.
- If a price estimate is required, please note it accordingly *and be sure to include a fax number.*

Providing the above information assists in the expedient repair and return of your unit.

**Failure to provide this information can result in processing delays.**

**ENMET** charges a one hour minimum billing for all approved repairs with additional time billed to the closest tenth of an hour. All instruments sent to **ENMET** are subject to a minimum \$30 evaluation fee, even if returned unrepaired. Unclaimed instruments that **ENMET** has received without appropriate paperwork or attempts to advise repair costs that have been unanswered, after a period of 60 days, may be disposed of or returned unrepaired COD with the evaluation fee.

Service centers may have different rates or terms. Be sure to contact them for this information.

**Repaired instruments are returned by UPS/FedEx Ground and are not insured unless otherwise specified. If expedited shipping methods or insurance is required, it must be stated in your paperwork.**

**Note:** Warranty of customer installed components.

If a component is purchased and installed in the field, and fails within the warranty term, it can be returned to **ENMET** and will be replaced, free of charge, per **ENMET**'s returned goods procedure.

If the entire instrument is returned to **ENMET** Corporation with the defective item installed, the item will be replaced at no cost, but the instrument will be subject to labor charges at half of the standard rate.



# Repair Return Form

**Mailing Address:**  
ENMET Corporation  
PO Box 979  
Ann Arbor, Michigan 48106

**Shipping Address:**  
ENMET Corporation  
Attn: Repair Department  
680 Fairfield Court  
Ann Arbor, Michigan 48108

**Phone Number:** 734.761.1270  
**FAX Number:** 734.761.3220

**Your Mailing Address:**

**Your Shipping Address:**

\_\_\_\_\_  
\_\_\_\_\_  
\_\_\_\_\_  
\_\_\_\_\_

\_\_\_\_\_  
\_\_\_\_\_  
\_\_\_\_\_  
\_\_\_\_\_

**Contact Name:** \_\_\_\_\_ **Your Phone:** \_\_\_\_\_

**Your PO/Reference Number:** \_\_\_\_\_ **Your FAX:** \_\_\_\_\_

**Payment Terms:**  COD  
(Check one)  VISA / MasterCard \_\_\_\_\_  
Card number Expiration

**Return Shipping Method:**

- UPS:  Ground  3 Day Select  Next Day Air  ND Air Saver  2-Day Air
- Federal Express:  Ground  Express Saver  P-1  Standard  2-Day Air
- FedEx Account number: \_\_\_\_\_

**Would you like ENMET to insure the return shipment?**

No  Yes **Insurance Amount:** \$ \_\_\_\_\_