

ENMET Corporation
PO Box 979
Ann Arbor, MI 48106-0979

GS-24-DF
Manual

80003-142
October 2003
MCN-314, 12/05/03

Table of Contents

1.0 INTRODUCTION	1
1.1 UNPACK	1
1.2 CHECK ORDER.....	1
1.3 SERIAL NUMBERS.....	1
2.0 FEATURES	2
3.0 INSTALLATION	3
4.0 DISPLAY SETTINGS	4
4.1 CHANGING DISPLAY SETTINGS.....	4
5.0 MAINTENANCE	5
5.1 PUMP DIAPHRAGM REPLACEMENT.....	5
5.2 CHECK VALVE HOUSING REPLACEMENT.....	6
6.0 WARRANTY	7

List of Illustrations

FIGURE 1: FRONT VIEW	2
FIGURE 2: INTERIOR VIEW	3
FIGURE 3: PUMP FEATURES	5
FIGURE 4: DIAPHRAGM DETAILS	5
FIGURE 5: CHECK VALVE HOUSING REPLACEMENT DETAILS	6
FIGURE 6: PROPER ORIENTATION OF CHECK VALVE HOUSING AND GASKET	6

1.0 Introduction

The **ENMET GS-24-DF** is designed to be used with most **ENMET** Corporation stationary sensor/transmitters.

Specifications:

Flow Range	0 – 1 lPM, 2 – 0 CFM, or 0 – 2000 CCM
Power	24 VDC
Alarm Relay	Positive safety, 2A 30VDC, 0.4A 115VAC
Digital Display	Backlit
Alarms	Audio and LED indicators

NOTE: *All specifications stated in this manual may change without notice.*

1.1 Unpack

Unpack the **GS-24-DF** and examine it for shipping damage. If such damage is observed, notify both **ENMET** customer service personnel and the commercial carrier involved immediately.

Regarding Damaged Shipments

NOTE: It is your responsibility to follow these instructions. If they are not followed, the carrier will not honor any claims for damage.

- This shipment was carefully inspected, verified and properly packaged at our company and delivered to the carrier in good condition.
- When it was picked up by the carrier at **ENMET**, it legally became your company's property.
- If your shipment arrives damaged:
 - Keep the items, packing material, and carton "As Is." Within 5 days of receipt, notify the carrier's local office and request immediate inspection of the carton and the contents.
 - After the inspection and after you have received written acknowledgment of the damage from the carrier, contact **ENMET** Customer Service for return authorization and further instructions. Have your Purchase Order and Sales Order numbers available.
- ENMET** either repairs or replaces damaged equipment and invoices the carrier to the extent of the liability coverage, usually \$100.00. Repair or replacement charges above that value are your company's responsibility.
- The shipping company may offer optional insurance coverage. **ENMET** only insures shipments with the shipping company when asked to do so in writing by our customer. If you need your shipments insured, please forward a written request to **ENMET** Customer Service.

Regarding Shortages

If there are any shortages or questions regarding this shipment, please notify **ENMET** Customer Service within 5 days of receipt at the following address:

ENMET Corporation
680 Fairfield Court
Ann Arbor, MI 48108
734-761-1270 734-761-3220 Fax

1.2 Check Order

Check, the contents of the shipment against the purchase order. Verify that the **GS-24-DF** is received as ordered. If there are accessories on the order, ascertain that they are present. Check the contents of calibration kits. Notify **ENMET** customer service personnel of any discrepancy immediately.

1.3 Serial Numbers

Each **GS-24-DF** is serialized. These numbers are on tags on the equipment and are on record in an **ENMET** database.

2.0 Features

See Figure 1 and 2

Feature	Description
Power Terminal	This terminal provides connections for: the DC power (24 VDC) supplied from external power source, Sensor/Transmitters and 4-20mA
Display	LCD, Allows the user to verify and monitor the flow rate of the air sample. Standard flow rate, approximately 05 ℓ pm(liter per minute).
Indicator LED	Green/Red: When green indicates flow rate is sufficient. When red indicates flow rate is inadequate. Yellow: When on solid indicates GS-24-DF is in menu to change settings When flashing indicates GS-24-DF is in menu to calibrate(<i>factory use only</i>)
Sampling Pump	This electromagnetic diaphragm pump draws the air sample from the test area to the sensor chamber.
Pushbutton Switch	SW1: Menu Switch, this switch is for viewing/changing display settings. SW2: Select Switch, this switch is for temporary deactivating audio alarm and changing display settings.
Potentiometer	Flow Adjustment Potentiometer (POT)
Inlet Port	This port draws the air sample from the test area. For external piping, use 1/4" O.D. tubing. See section 4 for type of tubing to be used.
Outlet Port	This port expels the air sample after it passes the sensor. For external piping, use 1/4" O.D. tubing
Gas Sensing Chamber	This chamber directs the air sample to the gas sensor. Varies, depending on the type of sensor/transmitter.

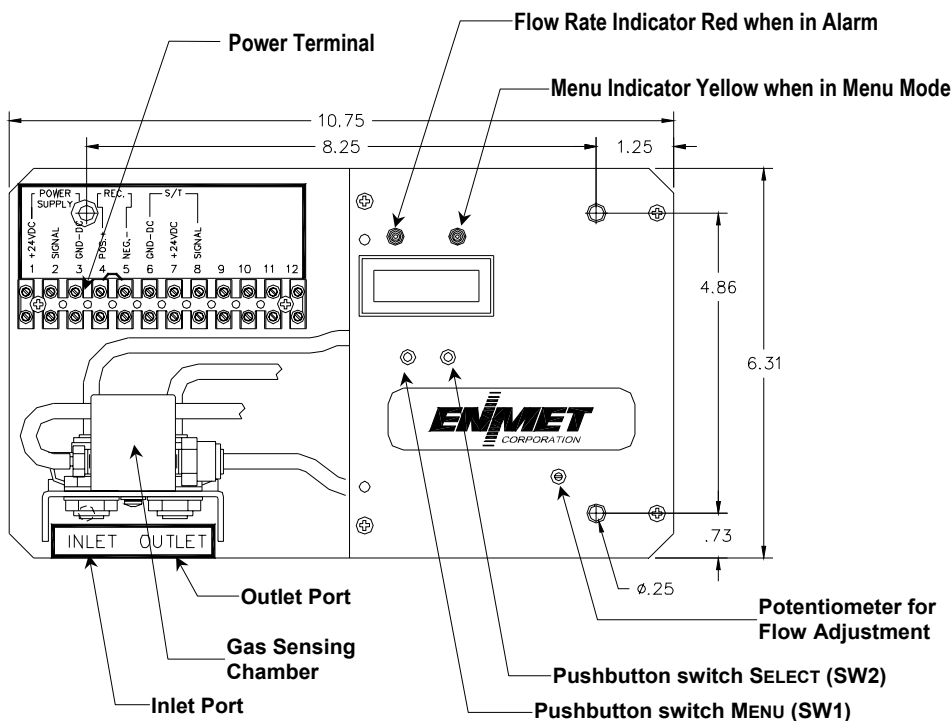

Figure 1: Front View

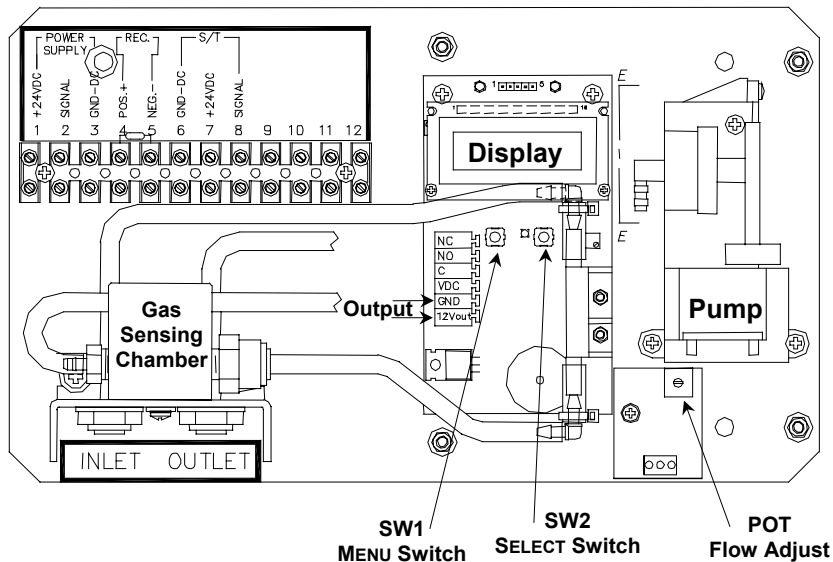

Figure 2: Interior View

3.0 Installation

The **GS-24-DF** needs to be level and as close to the area to be monitored as possible, to reduce transport time to the sensor/transmitter.

- Sensor/Transmitters can be located within the **GS-24-DF** or remotely.
- Inlet tubing must be compatible with the target gas.

Non reactive gases Standard vinyl or tygon tubing, **ENMET** part number 73073-001

Reactive gases Teflon lined vinyl or tygon tubing, **ENMET** part number 73073-029

- Caution should be used to insure that fluids do not enter the inlet tubing.
- Some types of gases require that the sample gas be removed from the area. This is accomplished with the outlet port.
- Power is supplied from an external source. Connect 24 VDC to terminal block positions 1 and 3.
- Note 12Vdc output is available on the pump module.
- After installing all the tubing and the sensor/transmitter, verify that there are no leaks in the system. Verification should be done by plugging the inlet tube. If the system is correct the flow meter reads zero and the flow alarm activates. If this does not happen, check all fittings and seals.

4.0 Display Settings

To display the current settings of the **GS-24-DF** use the push button switches. See figures 1 and 2 for location of switches.

Access the MENU and SELECT switches through holes in front. See figures 1 and 2.

To cycle through the display settings press:

MENU switch once = Low Flow alarm setting.

MENU switch twice = High Flow alarm setting.

MENU switch three times = Audio alarm on or off.

MENU switch four times = Raw sensor signal in millivolts.

To disable audio alarm press:

SELECT switch once = Audio Alarm (horn) disabled for approximately 1 minute.

4.1 Changing Display Settings

To change the current setting of the **GS-24-DF** use the push button switches.

Press and hold MENU switch for *three seconds*, display will indicate Units

Press MENU switch again, once for each setting: SET LO, SET HI, Set audio or Display menu.

When Units is displayed: Press SELECT switch to change value.

Press MENU switch to step through the values: LPM, CCM, CFM

Press SELECT switch to exit, Display steps to SET LO

When SET LO is displayed: Press SELECT switch to display the value.

Press MENU switch to change the value.

Press SELECT switch to Exit

When SET HI is displayed: Press SELECT switch to display the value.

Press MENU switch to change the value.

Press SELECT switch to Exit

When SET AUD is displayed: Press SELECT switch to display On or Off.

Press MENU switch to change

Press SELECT switch to Exit

When DISPLAY is displayed: Press SELECT switch to display On or Off.

Press MENU switch for Flow Dsp or Go/NoGo.

Press SELECT switch to Exit

5.0 Maintenance

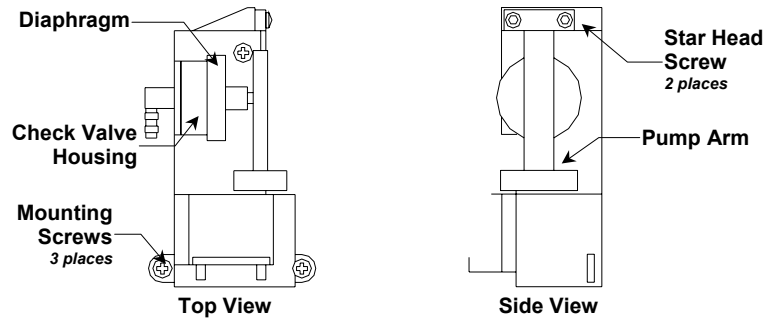

Figure 3: Pump Features

5.1 Pump diaphragm Replacement

If the diaphragm becomes damaged or torn, it can be replaced.

Replacement diaphragm **ENMET** part number 04018-117.

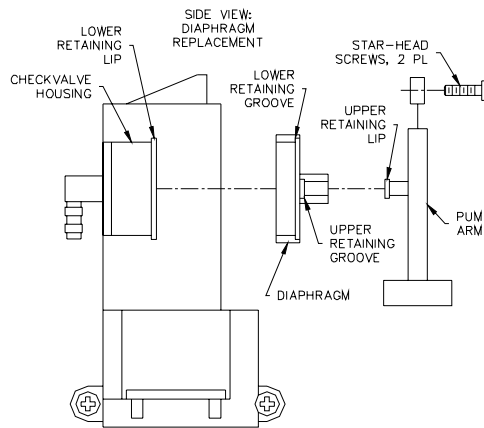

Figure 4: Diaphragm Details

- Remove 2 star head screws and pump arm. See figures 3 and 4.
- Remove damaged diaphragm from pump arm and replace with new diaphragm.
- Reattach pump arm and verify diaphragm is properly sealed to check valve housing.

5.2 Check Valve Housing Replacement

If the check valve becomes damaged or to warn to operate correctly it can be replaced.
 Pump repair kit **ENMET** part number 04018-116.

WARNING: The check valve housing and associated gasket must be installed in the proper position for the pump to operate correctly. If they are installed improperly the pump will flow in the wrong direction.

- Remove the outlet fittings, pump arm with diaphragm and note the orientation of the check valve housing and gasket. See figures 5 and 6.
- Remove flat-head screw and check valve housing.

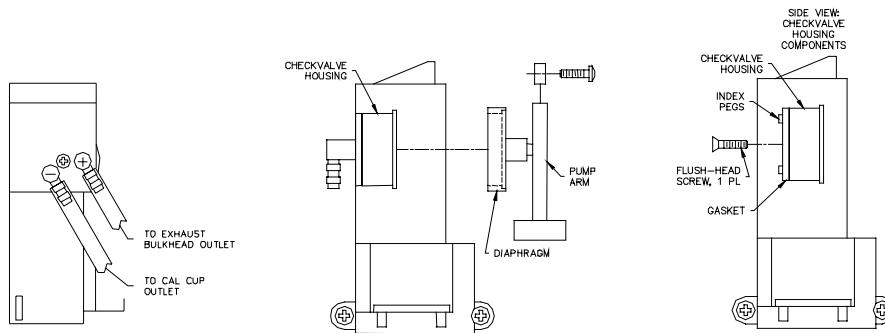

Figure 5: Check Valve Housing Replacement Details

- Verify that gasket and housing are in the proper position.

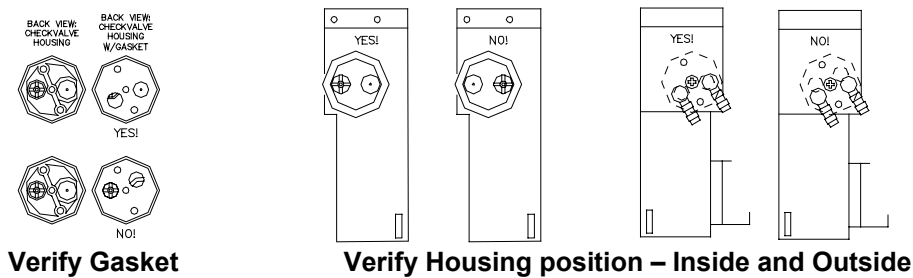

Figure 6: Proper Orientation of Check Valve Housing and Gasket

- Replace check valve housing with flat head screw.
- Verify proper position of check valve housing.
- Reattach pump arm and reseal diaphragm
- Reattach outlet fittings.

6.0 WARRANTY

ENMET warrants new instruments to be free from defects in workmanship and material under normal use for a period of one year from date of shipment from **ENMET**. The warranty covers both parts and labor excluding instrument calibration and expendable parts such as calibration gas, filters, batteries, etc... Equipment believed to be defective should be returned to **ENMET** within the warranty period (transportation prepaid) for inspection. If the evaluation by **ENMET** confirms that the product is defective, it will be repaired or replaced at no charge, within the stated limitations, and returned prepaid to any location in the United States by the most economical means, e.g. Surface UPS/RPS. If an expedient means of transportation is requested during the warranty period, the customer is responsible for the difference between the most economical means and the expedient mode. **ENMET** shall not be liable for any loss or damage caused by the improper use of the product. The purchaser indemnifies and saves harmless the company with respect to any loss or damages that may arise through the use by the purchaser or others of this equipment.

This warranty is expressly given in lieu of all other warranties, either expressed or implied, including that of merchantability, and all other obligations or liabilities of **ENMET** which may arise in connection with this equipment. **ENMET** neither assumes nor authorizes any representative or other person to assume for it any obligation or liability other than that which is set forth herein.

NOTE: When returning an instrument to the factory for service:

- Be sure to include paperwork.
- A purchase order, return address and telephone number will assist in the expedient repair and return of your unit.
- Include any specific instructions.
- For warranty service, include date of purchase
- If you require an estimate, please contact **ENMET** Corporation.

There are Return for Repair Instructions and Form on the last pages of this manual. This Form can be copied or used as needed.

Notes:



PO Box 979
680 Fairfield Court
Ann Arbor, Michigan 48106-0979
734.761.1270 Fax 734.761.3220

Returning an Instrument for Repair

ENMET instruments may be returned to the factory or any one of our Field Service Centers for regular repair service or calibration. The **ENMET** Repair Department and Field Service Centers also perform warranty service work.

When returning an instrument to the factory or service center for service, paperwork must be included which contains the following information:

- A purchase order number or reference number.
- A contact name with return address, telephone and fax numbers
- Specific instructions regarding desired service or description of the problems being encountered.
- Date of original purchase and copy of packing slip or invoice for warranty consideration.
- If a price estimate is required, please note it accordingly *and be sure to include a fax number.*

Providing the above information assists in the expedient repair and return of your unit.

Failure to provide this information can result in processing delays.

ENMET charges a one hour minimum billing for all approved repairs with additional time billed to the closest tenth of an hour. All instruments sent to **ENMET** are subject to a minimum \$30 evaluation fee, even if returned unrepaired. Unclaimed instruments that **ENMET** has received without appropriate paperwork or attempts to advise repair costs that have been unanswered, after a period of 60 days, may be disposed of or returned unrepaired COD with the evaluation fee.

Service centers may have different rates or terms. Be sure to contact them for this information.

Repaired instruments are returned by UPS/RPS surface and are not insured unless otherwise specified. If expedited shipping methods or insurance is required, it must be stated in your paperwork.

Note: Warranty of customer installed components.

If a component is purchased and installed in the field, and fails within the warranty term, it can be returned to **ENMET** and will be replaced, free of charge, per **ENMET**'s returned goods procedure.

If the entire instrument is returned to **ENMET** Corporation with the defective item installed, the item will be replaced at no cost, but the instrument will be subject to labor charges at half of the standard rate.

